

For Your Car—3 great electronic features

60c ■ APRIL 1969

Radio-Electronics®

TELEVISION · SERVICING · HIGH FIDELITY

A
GERNSBACK
PUBLICATION

BUILD—R-E EXCLUSIVE LAST-WORD STEREO SYSTEM

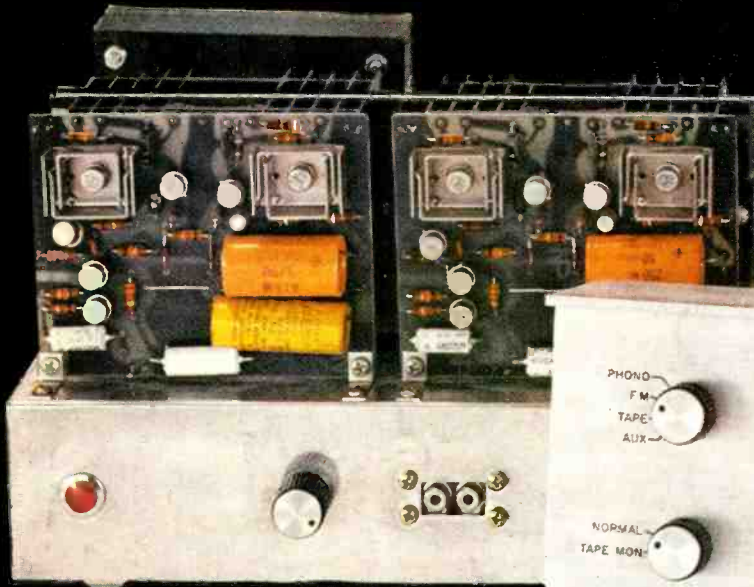

All solid state
125 watts per channel
IC preamp
variable-voltage tuning
IC i.f. strip—



\$200 IC Digital Clock

**Build a
\$20 Scope Camera**

**How it works —
Variable-Voltage Tuning**

You've been putting us on...

PIONEER® HEADSETS

Photo—Courtesy of Hi-Fi Trade News

It's taken you only a year to make Pioneer one of the fastest selling headsets in America today!

Take our SE-50 (so many of you have!), its quality literally speaks for itself. We've miniaturized Big Speaker System design and sound into each of its lightweight, comfortable, vinyl covered earcups. It features cone-type woofers and mylar-diaphragmed tweeters, resulting in extraordinarily smooth response from 20 Hz to 20 kHz. The SE-50's performance and features, at only \$49.95 are in a class by themselves. *That sounds astounding, but so does the SE-50!*

The Pioneer SE-20 (\$19.95) and the Pioneer SE-30 (\$29.95) equal and surpass the performance of headsets far more costly; and every Pioneer headset is supplied complete with its own permanent storage case. Pioneer has a reputation to live up to, and these headsets are fine examples of how we go about it.

Why don't you put us on? And make an enormous sound discovery for yourself—right between the ears!

Insist on a Pioneer demonstration — only at fine high fidelity dealers. Or write Pioneer for full details on the entire Pioneer component line and the name of your nearest franchised Pioneer dealer.



SE-30



SE-20



SE-50

PIONEER 
... More Value All-Ways!

PIONEER ELECTRONICS U.S.A. CORP., 140 Smith Street, Farmingdale, L.I., New York 11735 • (516) 694-7720

Circle 8 on reader service card

from Technician to ENGINEER

Advance beyond the technician level

Become an electronics engineer

The Grantham educational program in Electronics Engineering is designed to upgrade technicians to engineers, mostly by home study. In this program you can acquire an extensive knowledge of engineering and earn your BSEE Degree — for greater prestige, better pay, and more security.

In America's race to the moon and outer space, *more and more* engineers are needed. By becoming an electronics engineer, you can move into the forefront of technology and engineering, and be an important part of this exciting age. You can help make things happen and be properly rewarded for doing so.

The demand for engineers continues to increase; electronics engineers are needed in the space program and in many other military and domestic projects. In a recent survey conducted by the Engineering Manpower Commission of the Engineers Joint Council, it was found that engineering employment in the electrical and electronics industries is expected to increase by 40% in ten years. The need for engineers is increasing faster than the population as a whole. The survey report indicates that in the next decade, employers expect to need almost *twice as many* new engineering graduates as are likely to be available.

If you have the desire to be an engineer, the determination to stick to your objective, and a reasonably good aptitude for mathematics and technology, the Grantham educational program can produce the wanted results for you. But make no mistake about it, to become an electronics engineer requires work. You must be willing to do that work; otherwise you can never reach your objective, regardless of what course of instruction you may choose.

Grantham School of Engineering

Specializing in Electronics since 1951



1505 N. Western Ave.
Hollywood, Calif. 90027

Telephone:
(213) 469-7878

Circle 9 on reader service card

APRIL 1969

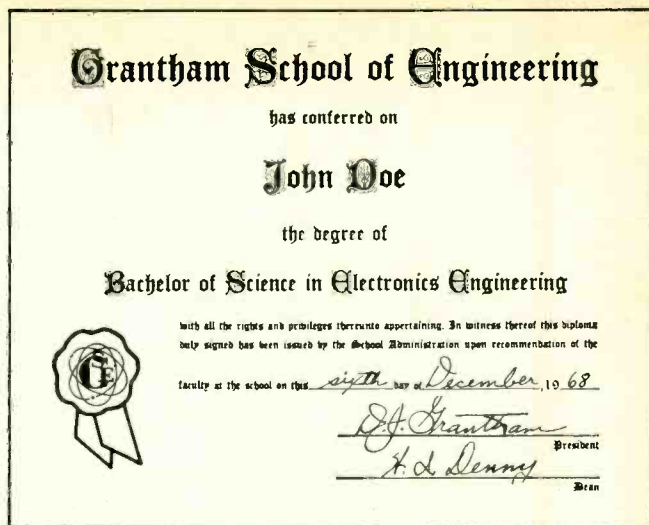

The Grantham program in Electronics Engineering consists of eight home-study "sections" and two weeks of attendance at the School in Hollywood. There are 80 lessons in the first home-study section, and 70 lessons in each additional section, for a total of 570 home-study lessons. The two-week attendance in Hollywood is required after completion of Section 5. Upon completion of the two weeks in Hollywood, you are awarded the ASEE Degree, and then upon completion of Section 8 you are awarded a Diploma in Electronics Engineering. Finally, upon earning 24 required semester-hour credits in English, Business, etc. (in other colleges) and transferring these credits to Grantham, you are awarded the Degree of Bachelor of Science in Electronics Engineering (the BSEE).

The Grantham educational program in electronics places heavy stress on fundamental concepts of logic and mathematics rather than on superficial manipulative skills. Since these fundamental ideas are largely unfamiliar to many electronics technicians, it is necessary to develop them in a systematic manner.

Accreditation and G.I. Bill Approval

Grantham School of Engineering is *accredited* by the Accrediting Commission of the National Home Study Council, *is approved* under the G.I. Bill, and *is authorized* under the laws of the State of California to grant academic degrees.

RE-4-69

Grantham School of Engineering
1505 N. Western Ave., Hollywood, Calif. 90027

Please mail your free Bulletin, which explains how the Grantham educational program can prepare me for my Bachelor of Science Degree in Electronics Engineering.

Name _____ Age _____

Address _____

City _____ State _____ Zip _____

NEW & TIMELY

Volume 40 Number 4

RADIO-ELECTRONICS

April 1969



CONSOLE UPDATES OLD SWITCHBOARD

MORRISTOWN, N.J.—The familiar telephone switchboard cluttered with patch cords has been phased out of service for long-distance calls here with a computer-like electronic console developed by Bell Labs.

The system, shown under test, automates many of the operator's functions, providing her with a visual display of the called and calling number, plus information necessary for billing. The system is similar to the electromechanical consoles replacing switchboards throughout the Bell System, but is more flexible. Controlled by a stored

FCC PLANS RFI RULE REVISIONS

WASHINGTON, D.C.—The boom in consumer and industrial devices that generate radio-frequency interference (RFI) has a prompted Federal legislation authorizing the FCC to regulate the manufacture, import, sale, shipment or use of any potential RFI devices. Earlier Federal regulations restricted the FCC only to control of radio-frequency equipment use. The proposed FCC rules, which will influence companies previously unaffected by Federal regulations, require type approval, acceptance or certification prior to the sale or shipment of rf devices.

program, the console automatically records in its memory a number of details about a long-distance call. This first system to be installed will service all telephones in 11 nearby communities.

RESOLUTION DOUBLED IN COLOR TV TUBE

CHICAGO—A new TV color tube designed largely by computer is claimed to have twice the resolution of similar tubes by Admiral Corp. The 79-square-inch design is being used in a recently introduced 12-inch portable.

Spacing for the phosphor dot triad is 0.025 inch, compared to 0.056 inch in similar-size tubes made by Admiral's competitors.

Other features of the new tube are a temperature-compensated shadow mask for proper alignment between electron beam and phosphor dot, and a low-voltage focus system. The focusing feature utilizes voltages in the 400–500 range to maintain picture sharpness despite voltage changes in the home.

1200 ELECTROCUTIONS IN HOSPITALS ANNUALLY

Electronic and electrical instrumentation in hospitals helps save thousands of lives daily, but a recent computer study by a major insurance company has revealed it also takes some 1200 lives each year in the US through accidental electrocutions.

The figures, attributed to Dr. Carl W. Walter, a Boston surgeon, were reported at a recent meeting on reliability and medical instrumentation. The majority of the hospital patients killed were undergoing routine diagnostic test or treatment.

As reported in an issue of *Electronic News*, the causes of hospital accidental electrocutions appear to be growing in complexity as the instrumentation use increases.

A major problem is linking incompatible instruments simultaneously to a patient, creating an ac current loop that causes fibrillation—erratic beating—of the heart. Poor circuit design contributes to dangerously high leakage current from some equipment on the market, and the problem is compounded by untrained hospital personnel who “wire” patients into a ground loop easily completed when a faucet or other equipment is touched.

Approval by Underwriters Laboratory is not a requirement for hospital instrumentation, the *Electronic News* report noted. Companies are increasing safety by using isolation transformers, self-destruct fusing devices and separate-ground three-wire power cables.

(continued on page 4)

LOOKING AHEAD

by DAVID LACHENBRUCH
CONTRIBUTING EDITOR

Toward color-fast TV

An important new color television battle may be shaping up toward an eventual decision by the FCC: Should station signal tolerances be tightened or television receivers made more elaborate and expensive?

This prospect now seems probable on the basis of significant discoveries in field tests by an all-industry engineering committee charged with investigating “the disturbing lack of uniformity among color television pictures.” The field tests, in Chicago, used closed-circuit and off-the-air material from three television stations received on four “top-of-the-line” color sets, all with automatic chroma control (ACC), made by four leading manufacturers.

The tests revealed that variations in the transmitted signal permitted by FCC specs produced different results on different receivers. In a preliminary report, the committee chairman, K. Blair Benson of CBS, drew these conclusions:

(1) “Signal specifications related to hue and saturation permit wide excursions, some of which subjectively are quite objectionable, depending upon the home receiver design.

(2) “Receivers may be affected by variations in burst timing, duration and amplitude. The degree of variations in picture quality is dependent upon the circuit design.

(3) “Transmission can introduce phase errors

(continued on page 4)

IN THIS ISSUE

Would you believe computerized cars are already here? Read Fred Holder's article on electronics in today's automobile and find out what's on the road.

Radio-Electronics

April 1969 • Over 60 Years of Electronics Publishing

AUTOMOTIVE ELECTRONICS

Electronic Ignition System	32	Bennett C. Goldberg
<i>Silicon transistors add zip</i>		
1 - 2 - 3 Sequential Turn Signal	38	J. A. Nunley
<i>Blink-blink-blink; right or left</i>		
Advances In Automotive Electronics	48	Fred W. Holder
<i>Look what Detroit's putting into the new cars</i>		

BUILD ONE OF THESE

125-Watt Stereo Amplifier	41	Ken Buegel
<i>And they're continuous rms—per channel!</i>		
Throbbing Vibrato	45	Jack Jaques
<i>Add oomph to those low notes</i>		
\$20 Oscilloscope Camera	52	Dale E. Coy
<i>Works just like the lab version</i>		

TELEVISION

In The Shop	17	Jack Darr
Stop Color TV Gremlins	35	Matthew Mandl
<i>In those color CRT input circuits</i>		
Service 2000 A.D.	47	Jack Darr
<i>Let's look into the future</i>		
Service Clinic	73	Jack Darr

GENERAL ELECTRONICS

Looking Ahead	2	David Lachenbruch
<i>Current happenings with future overtones</i>		
\$200 Digital IC Clock	25	A. E. Plavcan
<i>Tell time by the numbers</i>		
R-E Crossword Puzzler	34	Edmund A. Braun
Credit-Card Snoop	37	
VDR's, Thermistors and FET's	55	Sylvania Technical Staff
What's New In Variable-Voltage Tuning	58	Robert F. Scott
<i>How they're using it in the new sets</i>		
Equipment Report	92	Jack Darr
<i>Sencore TF151 FET-transistor tester</i>		

DEPARTMENTS

Correspondence	14	New Literature	88	Reader Service	76
New and Timely	2	New Products	78	Technotes	71
New Books	66	New Tubes	90	Try This One	94
		Noteworthy Circuits	95		

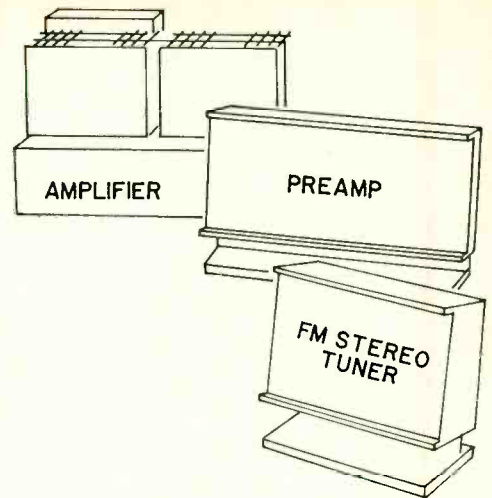

On the cover is a complete stereo hi-fi system. This month we show how to build the power amplifier. The preamp is in May and the FM tuner in June.

see page 41

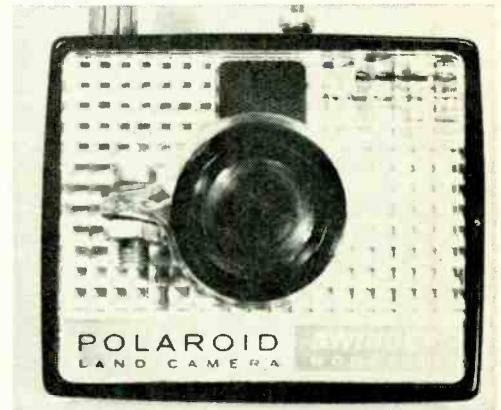

Need a scope camera? You can convert a Polaroid Swinger into a good one. Total cost including camera is \$20.

see page 52

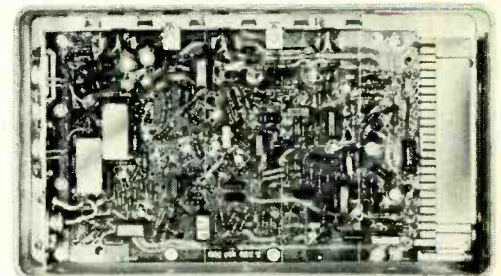

Electronic fuel injection is just one of the latest developments in automotive electronics. See what else is new.

see page 48

RADIO-ELECTRONICS, APRIL 1969, VOL. 40, No. 4
 Published monthly by Gernsback Publications, Inc., at Ferry St., Concord, N. H. 03302
 Editorial, Advertising, and Executive offices: 200 Park Ave. S., New York, N.Y. 10003. Subscription Service: Boulder, Colo. 80302.
 Second-class postage paid at Concord, N. H. Printed in U.S.A. One-year subscription rate: U.S. and possessions, Canada, \$6.
 Pan-American countries, \$7. Other countries, \$7.50. Single copies: 60¢. ©1969, by Gernsback Publications, Inc. All rights reserved.
 POSTMASTER: Notices of undelivered copies (Form 3579) to Boulder, Colo. 80302.



Member,
 Institute of High Fidelity.
 Radio-Electronics is indexed in
 Applied Science & Technology
 Index (formerly Industrial
 Arts Index)

WILL IT BITE?

No, but it'll stay dry while carrying telephone signals underground. "It" is a cable whose wires have been encapsulated in a mixture of petroleum jelly and plastic. The inexpensive mixture was concocted at Bell Labs for use in the Bell System's program to reduce the number of aerial telephone wires. The waterproof cable is being field-tested in several states.

H-FI WATTAGE WAR

NEW YORK, N.Y.—Would you prefer 40 watts of hi-fi stereo power or 120 watts? Unfortunately for the consumer, an amplifier can be rated with *both* wattages. The problem faced by the hi-fi industry became apparent at a recent press briefing in which the Institute of High Fidelity and the Electronic Industries Association rejected a proposal that Federal amplifier rating standards be established.

Industry representatives showed how misleading ratings can be: Under IHF standards, a 40-watt amplifier (20 per channel) would be rated at rms continuous power with 1% total harmonic distortion (THD). But, since the 1000-Hz tone used for the continuous-power rating bears little resemblance to music, the amplifier wattage could be jumped to 100 watts peak music power without exceeding 1% THD. Want more power? Just switch to EIA's rating system, which tolerates a 5% distortion level. Now the 40-watter's volume control can be cranked up for a EIA peak music-power rating of 120 watts.

An IHF board member declared the hi-fi industry "has the technical background to police itself," but views on wattage ratings seem as far apart as ever. One major manufacturer is reportedly using test standards established by the IEEE.

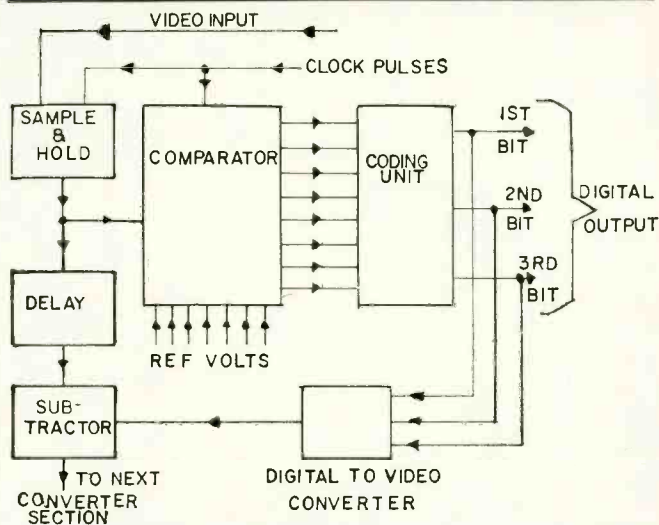

LOOKING AHEAD

(continued from page 2)

which, while not seriously objectionable in the field tests, were quite noticeable. Undoubtedly, in less rigorously maintained stations, these variations can be larger and very objectionable . . . The appropriate allocation of the source of variation among transmitters, propagation and receiver is not clear.

Particularly in connection with variations in the color burst, Benson urged "a careful weighing of the economics of signal specification changes vs more elegant receiver design." More field tests are planned, primarily for further study of the role of phase errors in color variations on home receivers.

At the committee's direction, other color uniformity studies are being conducted simultaneously in the fields of color film characteristics, standardization of studio monitors and phosphors, video tape equipment, camera colorimetry and development of test-signal standards to evaluate and control overall performance of the color sys-

(continued on page 6)

DIGITAL TV TRANSMISSION DEVELOPED

LONDON—British Broadcasting Corp. engineers have developed equipment that enables TV signals to be transmitted with digital techniques. The method, called pulse code modulation (PCM), samples a video signal at regular intervals and converts the sample into pulses that represent a binary code. PCM techniques have been adopted for data transmission over telephone lines in this country.

The BBC system being studied samples a 625-line, 5.5-MHz TV signal approximately 13 million times a second. The bit rate, or number of pulses per sample, must be seven or eight bits for high-quality pictures. Prototype equipment using six bits permits 64 brightness levels, which is sufficient except for certain scenes. The BBC converter shown in the diagram is a series-parallel design in which the three most significant digits are extracted by a parallel converter, and the three least significant digits by another converter in series with the first. Before being sent to the second converter, the three most significant digits are reconverted to analogue form and subtracted from the original signal.

Chief advantage of PCM for TV transmission is its immunity to small signal changes that can raise havoc with complex color signals. With PCM, pulse shape can vary considerably before becoming unrecognizable at the receiving end. The system was described in the magazine *Electronics Australia*.

(continued on page 6)

IN THIS ISSUE

Is the transistor on the way out? Why did news of a new glassy semiconductor cause rumbles on the stock exchange and front-page headlines throughout the country? Fred Shunaman's article tells the story behind the headlines.

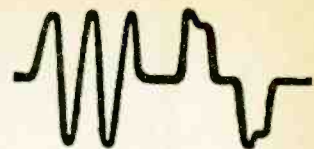

IC's..for automatic control of slide or film projector systems.



Typical TO5 IC Package

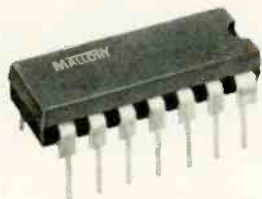

Typical Plastic Encapsulated IC

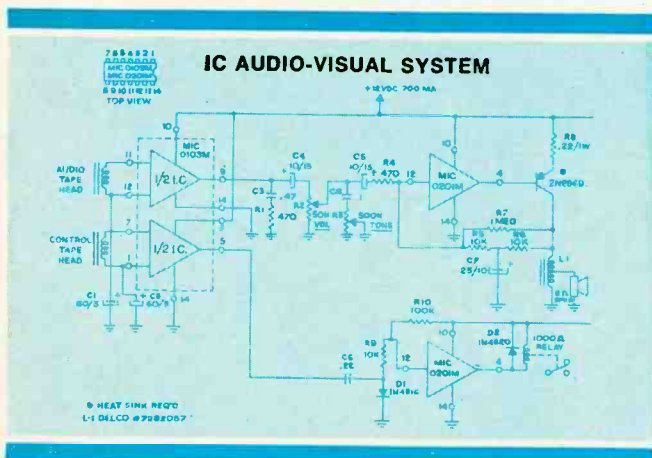

ORDERING INFORMATION

Packaging: *Standard Pack: One Per Card.
Bulk Pack: 25 Per Box.

Product Description:

MIC0101—Preamplifier MIC0201—Driver Amplifier
MIC0103—Dual Preamplifier

PART NUMBER	CASE STYLE	PART NUMBER	CASE STYLE
MIC0101D	TO5 CAN	MIC0201M	INLINE MOLDED
MIC0201D	TO5 CAN	MIC0103H	TO5 CAN
MIC0101M	INLINE MOLDED	MIC0103M	INLINE MOLDED

*Specify Packaging Desired

We joined 3 low-cost integrated circuits, a discrete audio power amplifier and a 2-channel tape player. Result: a new method to automatically control slide or film projector systems.

Audio messages are recorded on one channel and the control signal (tone burst) on the other channel. At the end of a message, channel 2 gets the keying tone burst and activates a relay driver circuit. This advances the projector to the next scene.

A Mallery MIC0103 dual channel IC preamp provides audio and keying signal amplification and equalization.

Channel 1 output feeds a Mallery MIC0201 driver amplifier which drives the audio output stage. The audio driver/output stage provides about 3.5 watts output at less than 10% distortion for input signals of 10 mv or less. Up to 2.5 watts, distortion is less than 5%.

Frequency response for the audio amplifier is flat from 100 Hz to 8 KHz. Tone is controlled by potentiometer R3 and capacitor C6, and provides enough treble cut for most applications. Tape is equalized by resistor R1 and capacitor C3. These components give about 14 db of high frequency attenuation to compensate for recording emphasis.

The projector is controlled by components C8, R9, R10, D1, D2, a 1000 ohm relay and a Mallery 0201 driver amplifier IC. The IC is biased off by the resistor network (R9 and R10) in conjunction with diode D1. Incoming signals are peak-detected to bias on the IC which activates the relay. Resistors R9 and R10 control the threshold at which the IC turns on. The threshold will vary according to system requirements.

With the values shown, an 0.5 mv 3KHz output from the tape head will activate the relay. The relay driver IC should be sufficiently biased to keep it off until the keying signal is obtained. Otherwise, excessive dissipation will occur within the IC. Diode D2 protects the IC output device when the relay is de-energized.

Total circuit power consumption is 12 Vdc at about 700 ma. Power can easily be provided by a filament transformer and rectifier system.

For detailed descriptions and analysis of the integrated circuits in this application, write for Application Notes 1 and 2, to Mallery Distributor Products Company, a division of P. R. Mallery & Co. Inc., Indianapolis, Indiana 46206.

DON'T FORGET TO ASK 'EM — "What else needs fixing?"

Circle 10 on reader service card

LUNAR TV CAMERA

BALTIMORE, MD.—This TV camera is going to the moon with the Apollo astronauts. It's one of 17 built for NASA by Westinghouse, and uses a secondary electron conduction (SEC) imaging tube for extreme low-light sensitivity. A cable from the spacecraft provides the 6½ watts of power needed. Camera can "see" scenes invisible to the human eye, yet will not bloom when exposed to extremely brilliant images. Integrated circuits are used extensively.

LASER ART UNSAFE

NEW YORK, N.Y.—Health Department officials here decided public eye safety came before modern art when they shut down an entry in a competitive museum exhibit. The work, a rectangular plastic-panel construction, uses several mirrors to bounce a laser beam from one panel to another. The Health Department said a safer method of viewing the exhibit than a Plexiglas window would be required.

(continued on page 15)

LOOKING AHEAD

(continued from page 4)

tem from original scene to the picture viewed in the home.

Vhf-uhf tuning 'equality'

One FCC proceeding involving TV set design is already under way. It concerns an old problem, familiar to everyone who lives in an area with numerous uhf stations: the relative difficulty of tuning the uhf band, as compared to the vhf.

The commission says it has no quarrel over the quality of uhf tuners, only with the relative ease of tuning. Under the authority of the all-channel law, which requires uhf tuners in all sets sold, the FCC has proposed to decree tuning "parity" between both bands. It thinks uhf stations are at a disadvantage when two separate tuning knobs must be used—the vhf selector with detents, the uhf with a continuous-tuning radio-type dial. The FCC would like to see all uhf channels marked on the dial as vhf channels are.

This leaves set manufacturers in something of a dilemma, since it's a matter of giving 83 uhf channels tuning equality with only 12 vhf's. (This equal treatment may be difficult and costly.) Nevertheless, the commission probably will establish rules to provide for more nearly equal ease in tuning, giving the industry a considerable amount of lead time to make the changeover.

Electronic tuning in '69

One of the most promising methods to bring about vhf-uhf tuning equality appears to lie in all-electronic varactor (variable-capacitance) diode tuning, using such methods as pushbuttons or a potentiometer control to change the tuner's resonant frequency electronically, with no moving parts in the tuner itself.

Diode TV tuning has become increasingly popular in Europe, where, it is estimated nearly 50% of all sets made in 1969 will use it. However, because of closer spacing between stations in the U.S., European tuning varactors have not been considered selective enough for use here.

Tuner and set manufacturers here now are giving top priority to development of all-electronic tuners. It's

(continued on page 12)



Radio-Electronics

HUGO GERNSBACK (1884-1967)
founder

M. HARVEY GERNSBACK,
editor and publisher

LARRY STECKLER, managing editor

Robert F. Scott, W2PWG
senior technical editor

John R. Free, associate editor

Jack Darr, service editor

I. Queen, editorial associate

Matthew Mandl, contributing editor

David Lachenbruch, contributing editor

Carrie Ng, editorial assistant

Bruce Ward, production manager

Elizabeth Shincel, production assistant

G. Aliquo, circulation manager

Cover by Harry Schlack

RADIO-ELECTRONICS is published by Gernsback Publications, Inc. 200 Park Ave. South New York, N.Y. 10003 (212) 777-6400

President: M. Harvey Gernsback
Vice President-Secretary: G. Aliquo

ADVERTISING REPRESENTATIVES

EAST

John J. Lamson, Eastern Sales Mgr.

MIDWEST/N.&S. Car., Ga., Tenn.

Robert Pattis, the Bill Pattis Co., 4761 West Touhy Ave., Lincolnwood, Ill. 60646 (312) 679-1100

W. COAST/Texas/Arkansas/Oklahoma

J. E. Publishers Representative Co., 8380 Melrose Ave., Los Angeles, Calif. 90069, (213) 653-5841; 420 Market St. San Francisco, Calif. 94111, (415) 981-4527

UNITED KINGDOM

Publishing & Distributing Co., Ltd., Mitre House, 177 Regent St., London W.1, England RE 6534,5

SUBSCRIPTION SERVICE: Send all subscription orders and correspondence to RADIO-ELECTRONICS, Subscription Department, Boulder, Colo. 80302.

MOVING? For change of address, allow six weeks, furnishing both the old and new addresses and if possible attaching label from a recent issue below. Otherwise please print clearly your name and address exactly as it appears on your label.

ATTACH LABEL HERE

name (please print)

address

city state zip code

Mail to: RADIO-ELECTRONICS
SUBSCRIPTION DEPT., BOULDER, COLO. 80302

You can pay \$600 and still not get professionally approved TV training.

Get it now for \$99.

Before you put out money for a home study course in TV Servicing and Repair, take a look at what's new.

National Electronic Associations did. They checked out the new TV training package being offered by ICS. Inspected the six self-teaching texts. Followed the step-by-step diagrams and instructions. Evaluated the material's practicality, its fitness for learning modern troubleshooting (including UHF and Color).

Then they approved the new course for use in their own national apprenticeship program.

They went even further and endorsed this new training as an important step for anyone working toward recognition as a Certified Electronic Technician (CET).

This is the first time a self-taught training program has been approved by NEA.

The surprising thing is that this is not a course that costs hundreds of dollars and takes several years to complete. It includes no kits or gimmicks. Requires no experience, no elaborate shop setup.

All you need is normal intelligence and a willingness to learn. Plus an old TV set to work on and some tools

and equipment (you'll find helpful what-to-buy and where-to-buy-it information in the texts).

Learning by doing, you should be able to complete your basic training in six months. You then take a final examination to win your ICS diploma and membership in the ICS TV Servicing Academy.

Actually, when you complete the first two texts, you'll be able to locate and repair 70% of common TV troubles. You can begin taking servicing jobs for money or start working in any of a number of electronic service businesses as a sought-after apprentice technician.

Which leads to the fact that this new course is far below the cost you would expect to pay for a complete training course. Comparable courses with their Color TV kits cost as much as six times more than the \$99 you'll pay for this one.

But don't stop here. Compare its up-to-dateness and thoroughness. Find out about the bonus features—a dictionary of TV terms and a portfolio of 24 late-model schematics.

Get all the facts. Free. Fast. Mail the reply card or coupon below.

ICS[®] Dept. M5513RC
Scranton, Penna. 18515

Yes, I'd like all the details about your new TV Servicing/Repair basic training package. I understand there's no obligation. (Canadian residents, send coupon to Scranton, Pa. Further service handled by ICS Canadian, Ltd.)

Name _____
Street _____
City _____ State _____ Zip _____

Prices slightly higher outside U. S. and Canada.

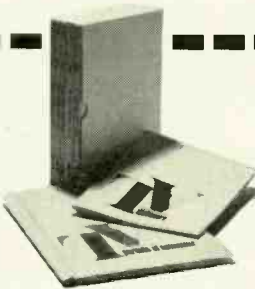

NRI GIVES YOU THE RIGHT BALANCE...

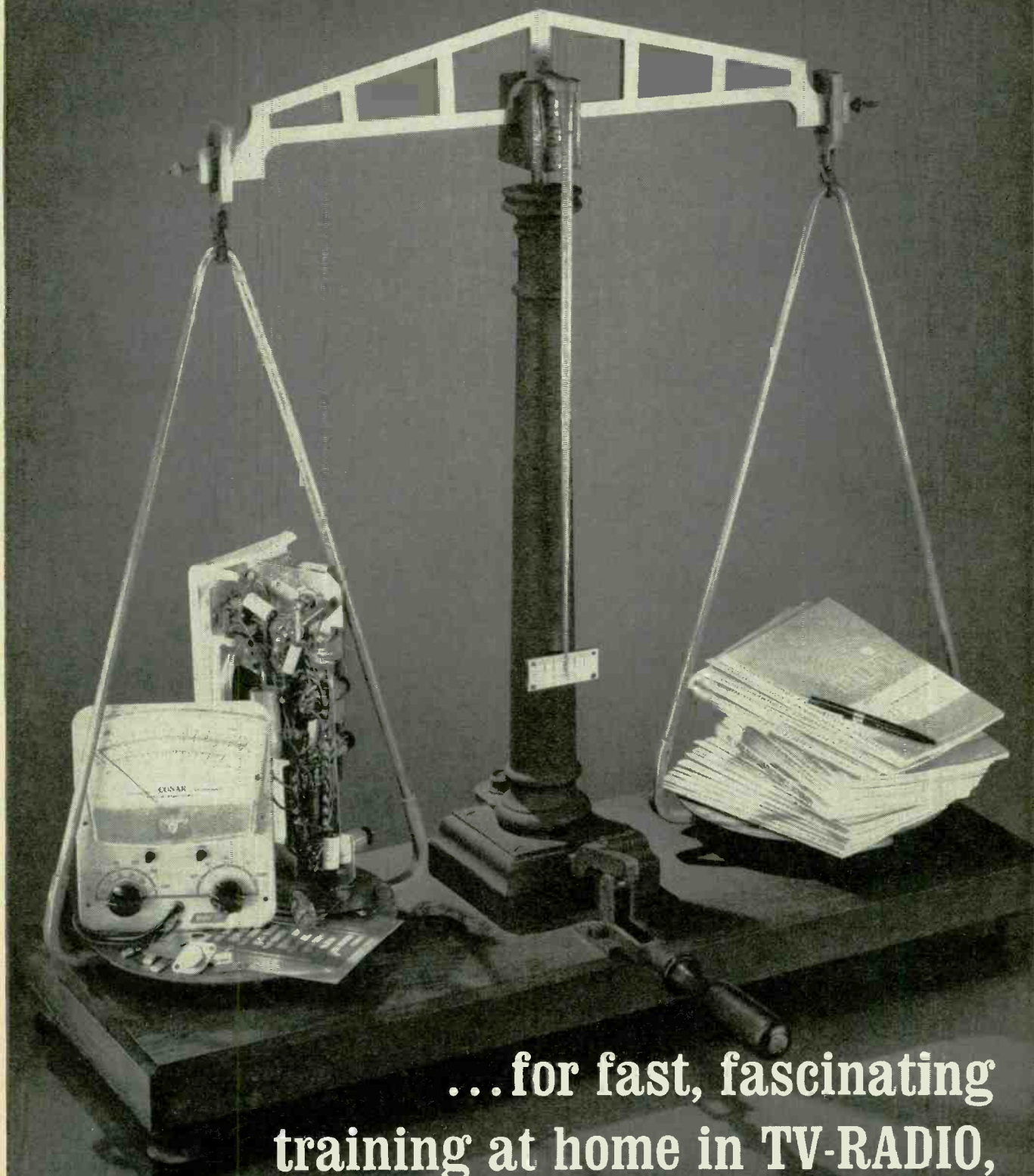

...for fast, fascinating
training at home in TV-RADIO,
COMMUNICATIONS, ELECTRONICS

Experience is still your best teacher

Here's how you get it with NRI job-simulated training

Ask any teacher, job counselor, engineer, technician or prospective employer about the need for practical application of theory in Electronics. He'll tell you Electronics is as much a "hands on" profession as dentistry or chemistry. That's the way you learn at home with NRI. You put to work the theory you read in "bite-size" texts, using designed-for-learning lab equipment you build with professional components. You introduce defects into circuits, do experiments, until the "why" of circuitry and equipment operation comes clear through demonstration. You gain experience with transistors and solid-state designs as well as conventional tube circuits.

NRI lab equipment is designed and engineered from chassis up for education through practical experience — not for entertainment. The fact that the end results of your projects are usable, quality products is a personal bonus for you. Everything about NRI training has but one ultimate goal — to make you **employable** in your chosen field of Electronics by preparing you to prove your practical understanding of actual equipment; by giving you the equivalent of months, even years, of on-the-job training. There is no end of oppor-

tunity for the trained man in Electronics. You can earn extra money in your spare time, have your own full-time business, or qualify quickly for career positions in business, industry, government. Discover for yourself the ease and excitement of NRI training. Mail the postage-free card today for the new NRI Color Catalog. No obligation. No salesman will call. NATIONAL RADIO INSTITUTE, Electronics Div., Washington, D. C. 20016.

NRI has trained thousands



L. V. Lynch, Louisville, Ky., was a factory worker with American Tobacco Co., now he's an Electronics Technician with the same firm.

He says, "I don't see how the NRI way of teaching could be improved."



G. L. Roberts, Champaign, Ill., is Senior Technician at the U. of Illinois Coordinated Science Laboratory. In two years he received five pay raises.

Says Roberts, "I attribute my present position to NRI training."



Ronald L. Ritter of Eatontown, N.J., received a promotion before even finishing the NRI Communications course, after scoring one of the

highest grades in Army proficiency tests. He works with the U. S. Army Electronics Lab, Ft. Monmouth, N.J. "Through NRI, I know I can handle a job of responsibility."



Don House, Lubbock, Tex., went into his own Servicing business six months after completing NRI training. This former

clothes salesman just bought a new house and reports, "I look forward to making twice as much money as I would have in my former work."

APPROVED UNDER NEW GI BILL. If you served since January 31, 1955, or are in service, check GI line on postage-free card.

Accredited by the Accrediting Commission of the National Home Study Council

Over 50 Years of Leadership



in Electronics Training

YOU GET MORE FOR YOUR MONEY FROM NRI

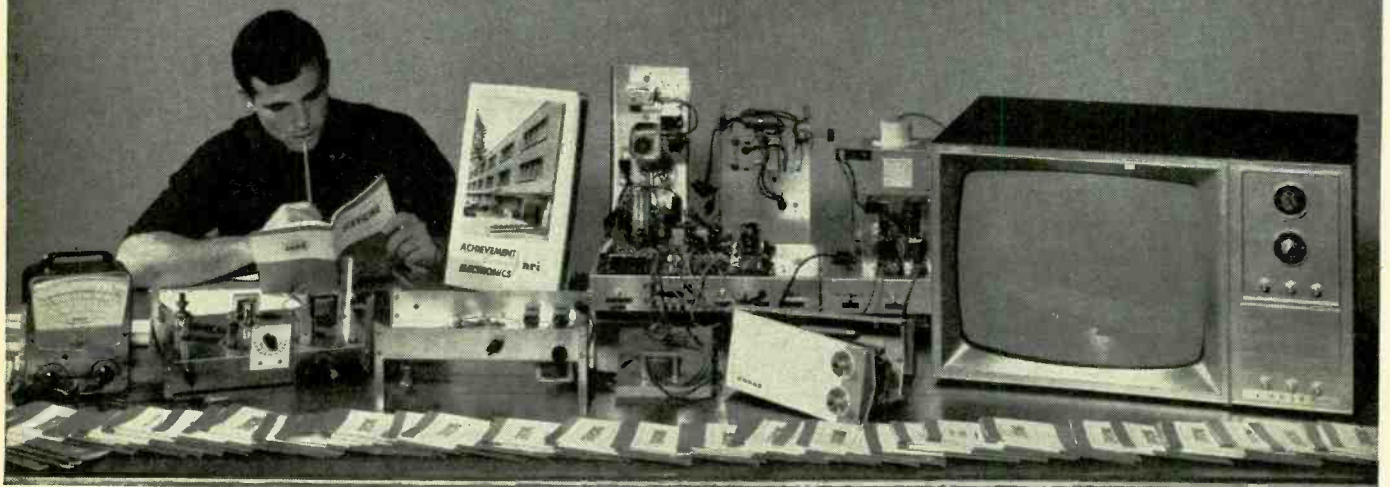

Everything you see here is included in one typical NRI home study course. Other courses are equally complete. Your training starts with the NRI Achievement Kit, sent the day you enroll. It contains the first of your "bite-size" texts which are programmed with

designed-for-learning professional lab equipment. Step-by-step, you learn with your hands as well as your head. You discover the "why" of circuitry as you acquire the professional's most valuable tool — practical experience in Electronics.

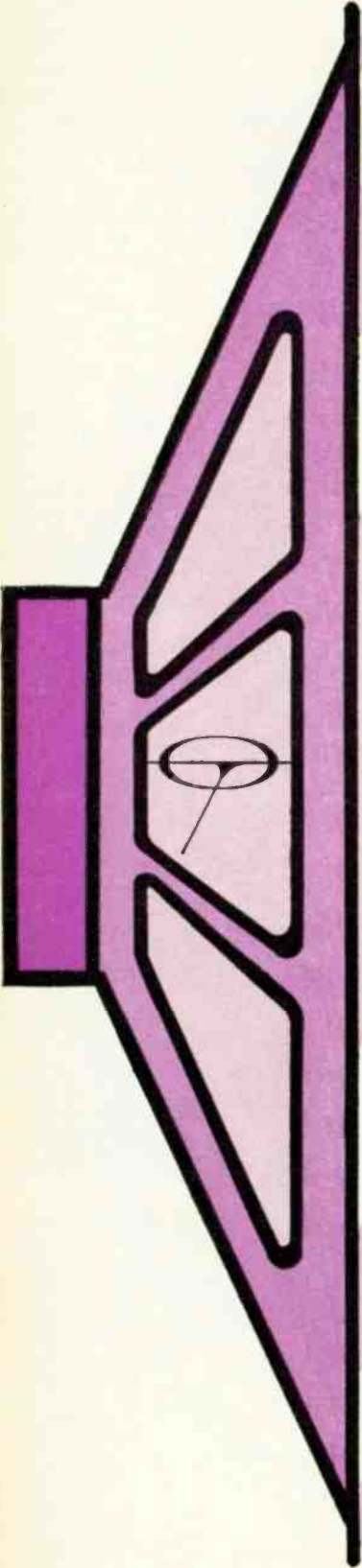

as simple as sound

The reason for Oxford leadership is simple, in one word—quality... consistently higher quality for every new equipment or replacement need.

Whatever your speaker requirements may be—radio or TV, high-fidelity or stereo, inter-com, automotive commercial sound, or musical instrument—any and every place where quality sound reproduction is a “must”, Oxford is your best buy on any count.

For the full story on what this quality can do for you, write today for your free copy of the big new Oxford catalog. You'll learn first hand why the buy word in speakers today is... Oxford, of course!

OXFORD



A Division of
Oxford Electric Corporation
3911 S. Michigan Ave.
Chicago, Ill. 60653



Circle 13 on reader service card

LOOKING AHEAD

(continued from page 6)

certain that at least one manufacturer will introduce a diode-tuned TV set in the mid-1969 model changeover, while several others will have them in time for this year's Christmas selling season. These new devices, appearing first only on higher-priced color sets, may use new and interesting channel-selection devices. One manufacturer is expected to solve the problem of tuning equality with a signal-seeking pushbar control similar to those used on some auto radios.

Home movies on color TV

A 23-inch television set that also can show 8mm home movies is due for introduction in the next few weeks. It will be offered by Sylvania, which one year ago premiered its Scanner Color Slide Theater, a color set which shows 35mm home slides on its screen. The color movie theater is expected to incorporate an Eastman Kodak film-transport mechanism, but use TV scanner techniques instead of optical projection.

IC's in consumer products

The number of active integrated-circuit elements used in consumer electronic products—television, radio, phonographs, tape recorders, etc.—will exceed receiving tubes by 1971, and discrete semiconductors by 1975. That's the projection of Motorola Semiconductor Products. Motorola says 78% of all active components in consumer electronic products built this year will be discrete semiconductors, while 18% will be tubes and 4% will be IC's. Discrete semiconductors' share will remain at 78% in 1970, Motorola forecasters think, but IC's will gather a 9% share at the expense of tubes, which will decline to 13%.

They still watch

You may think people have given up on television, but it's just not true. Analyzing rating surveys, the Television Bureau of Advertising has found that the average family watched more television than ever in 1968—5 hours and 48 minutes per week, or 6 more minutes a week than in 1967. The study credited new color sets for much of the increase.

Meanwhile, color has passed something of a landmark. As 1969 started, the NBC research department reported that almost one-third of all television-equipped households—19.2 million of them—had color sets. The total number of color sets as of Jan. 1 was about 20.1 million. The number of sets is higher than the number of color households because some homes have two color sets, and some sets are in hotels, bars, offices, etc.

Fax via FM

There's increasing talk about public facsimile transmission these days, and most of it centers on the use of television stations as origination points. RCA has been conducting experiments in transmitting material during the vertical blanking interval between TV frames.

A New York firm, Comfax Communications Corp., now indicates that it plans to use FM stations for fax transmission, utilizing their subcarriers when they are not broadcasting in stereo, without interfering with regular programming. Comfax plans initially to confine its FM fax transmissions to specialized nonpublic uses—bank signature verifications, intracity transmittal of business documents—but it also claims it has a system which would make it possible to send newspapers to the home via the relatively narrow bandwidth of an FM subcarrier. **R-E**

measure



NEW RCA WV-500B all solid state, battery operated VoltOhmyst eliminates warm-up time, zero shift that can occur in tube voltmeters. Completely portable. Only \$79.00.* Now has eight overlapping DC current ranges from $2\mu\text{A}$ to 1.5A.



The RCA WV-38A Volt-Ohm Milliammeter is a rugged, accurate, and extremely versatile instrument. We think it's your best buy. Only \$52.00.* Also available in easy to assemble kit, WV-38A (K).

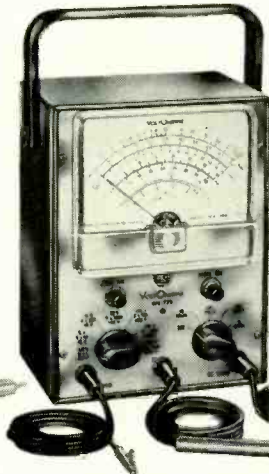

The RCA WV-77E Volt-Ohmyst[®] can be used for countless measurements in all types of electronic circuits. Reliability for budget price. Only \$52.00.* Also available in an easy to assemble kit, WV-77E (K).



The RCA WG-412A R-C circuit box can help you speed the selection of standard values for resistors and capacitors, either separately or in series or parallel R C combinations. Only \$30.00.* It's easy to use, rugged, and compact.

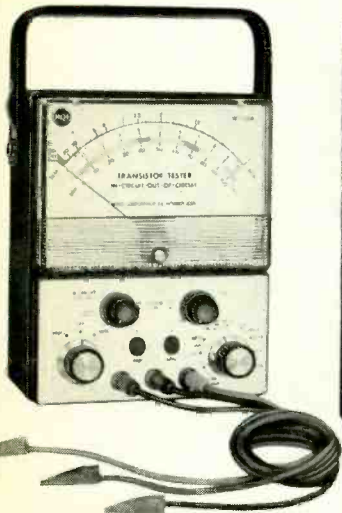

The RCA WT-501A in-circuit out-of-circuit transistor tester is battery operated, completely portable. It tests both low and high power transistors, has NPN and PNP sockets for convenient transistor matching for complementary symmetry applications. Only \$66.75.*



The RCA WC-506A transistor-diode checker offers a fast, easy means of checking relative gain and leakage levels of out-of-circuit transistors. Compact and portable, it weighs 14 ounces, measures $3\frac{3}{4}$ by $6\frac{1}{4}$ by 2 inches. Only \$18.00.*



The RCA WV-98C Senior VoltOhmyst is the finest vacuum-tube voltmeter in the broad line of famous RCA VoltOhmysts. Accurate, dependable, extremely versatile, it is a deluxe precision instrument. Only \$88.50.* Also available in an easy to assemble kit, WV-98C (K).

For a complete catalog with descriptions and specifications for all RCA test instruments, write RCA Electronic Components, Commercial Engineering, Dept. D39W, Harrison, N.J. 07029.

*Optional Distributor resale price. Prices may be slightly higher in Alaska, Hawaii, and the West.

LOOK TO RCA FOR INSTRUMENTS TO TEST/MEASURE/VIEW/MONITOR/GENERATE
Circle 14 on reader service card

RCA

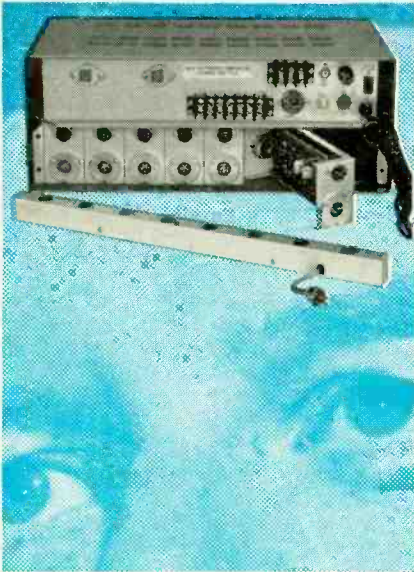

dream factory!

"Invent" a whole new sound system . . . fast 'n easy . . . with new BELL P/A MODULAR AMPS

Bell P/A's "stacking" principle gives you *unusual design flexibility*. Place up to 8 input modules in different positions . . . get thousands of possible input configurations.

FET's are located up front for true Hi Z input (or bal. lo Z with trans.). *Units have 20, 45, 90 or 200-watt output (RMS ratings)!* All silicon solid state design.

Exclusive, fully automatic output circuit protection (with signal light) saves time, labor, components . . . eliminates guesswork. *See your local electronics distributor, or send for full specs.*

BELL p/a
professional appeal

BELL P/A PRODUCTS CORPORATION
1209 North Fifth St., Columbus, Ohio 43201

Circle 15 on reader service card

(continued from page 6)

STATE TO COMBAT NOISE POLLUTION

STAMFORD, CONN.—Instruments like this are being used in a new program to combat noise on Connecticut highways. Data obtained will help to formulate laws controlling highway noise.

The devices contain sensitive microphones and sound-level meters that track and record noise levels from vehicles.

The builder, CBS Labs, is also developing an instrument for the state that will provide instantaneous photographs and chart readings of noisy vehicles. The suitcase-size instrument will use a split-screen camera and calibrated microphone to establish legal evidence against operators of noisy vehicles.

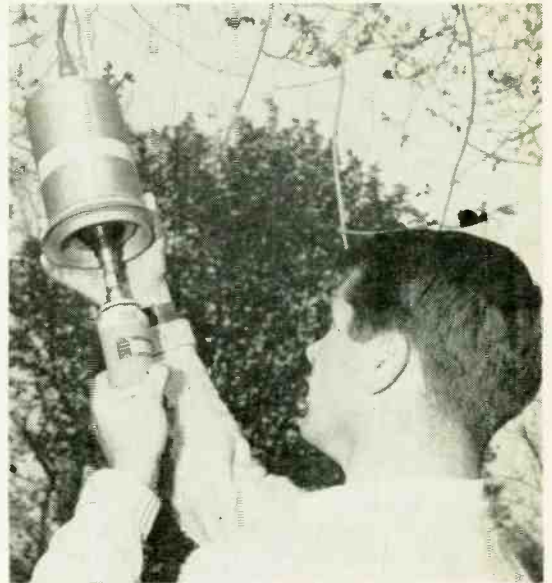

GIANT SATELLITE READY

The largest and most powerful communications satellite ever to be launched is shown undergoing final tests at Hughes Aircraft Co. The 1600-lb satellite is as tall as a two-story building and has a communications capability equivalent to 10,000 two-way telephone channels. Signals from the cluster of antennas on top of the satellite can be picked up by ground stations. The satellite is being launched for the Defense Department.

REPAIR LICENSE BILLS

Legislation that would require licensing of TV service techs is being introduced in the State Legislatures of New York and Pennsylvania. The New York bill would establish an advisory board to set license requirements and standards. Similar legislation sponsored by a Pennsylvania service association would additionally require service technicians to provide a statement showing all parts placed in a set, an itemized list of all charges, and name and address of repairer. **R-E**

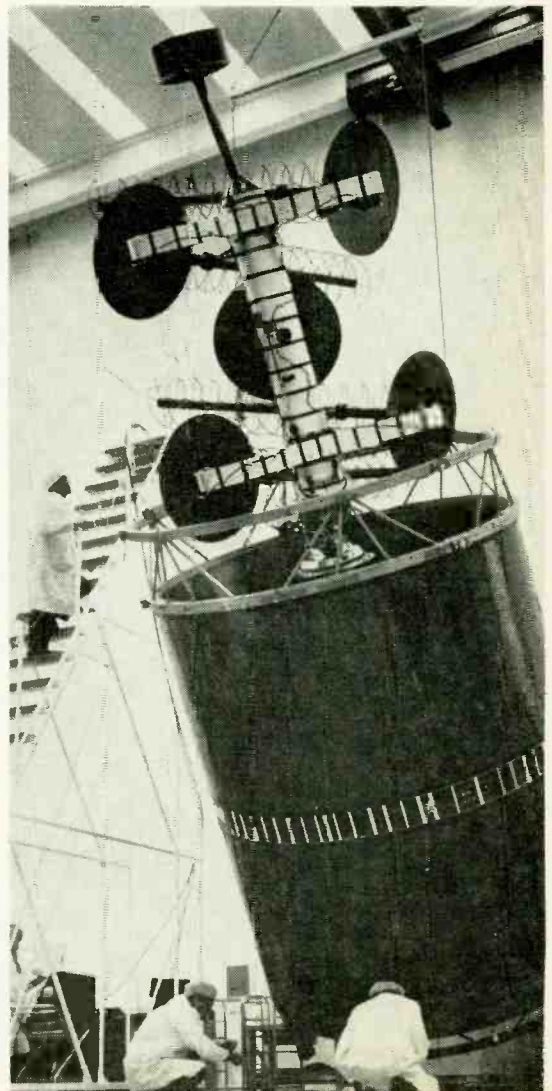

C

orrespondence

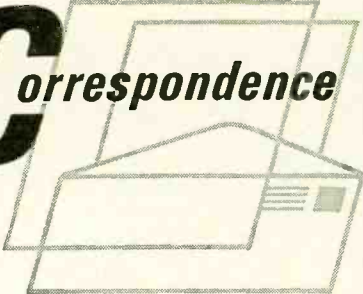

COMPLAINT DEPARTMENT

I wish to voice a formal protest to someone. Those little "earphones" that come with transistor radios are undoubtedly the most uncomfortable, ill fitting, unsanitary, low quality, always tangled listening devices ever made. Surely we consumers deserve better.

KEN GREENBERG
Chicago, Ill.

No one says you must use those little thingamabobs Ken. Just find a pair of good quality, comfortable headphones, fit an appropriate plug and use them. Only one point to remember, those good quality phones may cost more than the radio you're going to use them with.

ONLY A GUITAR AMPLIFIER

The Go-Go Guitar Amplifier in the November 1968 issue is just about what I've been looking for for some time. However, you state it is not hi-fi. How un-hi-fi is it? I am planning to build a stereo system with a reverb section and this is the first circuit I have run across that incorporates most of my requirements. I am primarily interested in FM stereo and records.

One thing I like about this circuit is that it is designed around the HEP solid-state components. I find them much easier to get than some of the parts you usually list in your construction articles.

By the way, I'm sure you didn't actually use a No. 313 lamp as shown in this unit. The lamp is rated at 28 volts and 170. Placed across the line as shown it would go off in one quick flash.

Do you have any plans for an FM tuner in the near future? I would like to see a solid-state tuner with an IC i.f. circuit.

DAVID C. SEARTZ
Aurora, Colo.

From the tone of your letter Dave, you want higher-fi than this guitar amplifier can deliver. Remember, it is

NEW DELTA DESIGN!

MODEL 3000 FET VOM

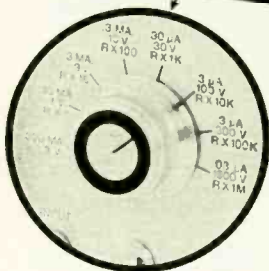
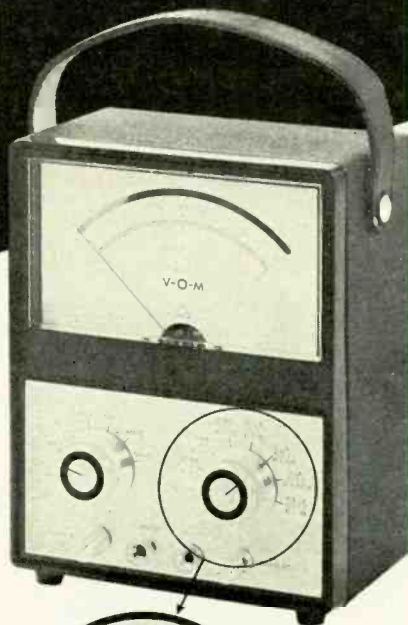

A unique and efficient instrument bridging the gap between a multimeter and a digital voltmeter!

Delta, pioneer of the famous Mark Ten® CD System, now offers a compact, versatile, and extremely sensitive VOM which combines FETs and ICs for extreme accuracy. Compact (6½" W x 8" H x 3½" D), portable, wt. 3¾ lbs. In full production at only

\$74.95
ppd.

Would you believe:

1. Mirror scale 200µ A D'Arsonval meter
2. Integrated circuit (IC) operational amplifier for extreme accuracy
3. FET input stage with current regulator
4. Two stage transistor current regulator and Zener diode on OHMS for absolute stability and accuracy
5. Voltage clippers for protection of input stage
6. Fully temperature compensated for low low zero drift
7. Ten turns ZERO and OHMS adjust potentiometers
8. Epoxy glass circuit boards and metal case
9. Enclosed switches
10. Uses readily available type AA cells
11. Uses standard test leads for maximum flexibility and ease of measurement
12. 10 Megohms input impedance

Available in Kit form: Feedback network with pre-selected components to eliminate all final calibration. Ready to use when assembled!

Kit:
Only **\$59.95** ppd.



DELTA PRODUCTS, INC.

P. O. Box 1147, Grand Junction, Colorado 81501

I enclose \$ _____ Please send postpaid:

_____ Model 3000 FET VOMs @ \$74.95 assembled

_____ Model 3000 FET VOMs @ \$59.95 kit form

Name _____

Address _____

City/State _____ Zip _____

DP 8-7

Circle 16 on reader service card

NOW - CHECK ALL TRANSISTORS IN OR OUT OF CIRCUIT ...

Flick function switch to left to check all regular transistors.

Flick function switch to right to check any FET.



Model TF151

all regular transistors plus the new field effect transistors.

You won't be stopped when you run into the new FETs that are wired into the latest hi-fi, newest TV receivers and nearly every other new device coming on the market. For the very first time, you can check them all, in or out of circuit. The TF151 works every time using tried and proven signal injection techniques. New, improved tests on special RF transistors and the latest high power transistors, mean that the TF151 is the only up-to-date transistor tester on the market. A new, exclusive setup book in rear compartment guides you to every test for over 12,000 transistors and FETs. The book is not needed for general service troubleshooting. Regular transistors are checked for beta gain and I_{cbo} leakage. FETs are checked for transconductance and I_{gss} leakage. **only \$129⁵⁰**

Your distributor just got this new tester in stock.
See him, it obsoletes all others.



SENCORE

NO. 1 MANUFACTURER OF ELECTRONIC MAINTENANCE EQUIPMENT
426 SOUTH WESTGATE DRIVE, ADDISON, ILLINOIS 60101

Circle 17 on reader service card

CORRESPONDENCE

(continued from page 15)

only a guitar amplifier. But if you can wait a couple of months longer you'll find a three article series with complete details on a hi-fi system that is really something. First we'll publish the premap and it's got an IC circuit. Then there's a power amplifier with two, 120-watt channels. Last there's an FM tuner that's just out of this world. Now how's that for keeping you on the edge of your seat.

FREQUENCY, MUSIC, AND HEARING

Dear Sir:

On page 22 of your October issue you suggest reopening discussion of the necessary bandwidth of high-fidelity amplifiers as related to the bandwidth of the human ear.

Actually, the extra bandwidth seems unavoidable, if amplifiers of low harmonic and intermodulation distortion are to be obtained. With practical tubes and transistors there is always nonlinearity of characteristic and appreciable values of feedback. ($-A\beta$) are needed to bring distortion and desired percentage levels. These magnitudes of $A\beta$, when added in amplifiers having reasonable audio bandwidth, lead to wider bandwidths than are necessary to cover the audible range.

Mathematically, the gain with feedback can be expressed as

$$A' = V_o/V_s = A + \frac{V_h V_s}{1 - A\beta}$$

where the harmonic distortion fraction V_h/V_s is seen to be reduced by the factor $1/(1 - A\beta)$. Thus the desirability of large ($-A\beta$) magnitudes. At the same time the upper bandwidth limit (half-power frequency), ω_2 with feedback, becomes

$$\omega_2' = \omega_2 (1 - A\beta)$$

when ω_2 is the bandwidth limit with no feedback.

Thus if we want to reduce the harmonic distortion from 6% ($V_h/V_s = 0.06$) to 0.6% by making $[1 - A\beta] = 10$, then $\omega_2' = 10\omega_2$, and we have expanded the upper bandwidth limit, perhaps from 10 kHz to 100 kHz.

Along with this comes the necessity to now control the phase shift out to 100 kHz, as well.

Of course, for high-fidelity we must reduce the harmonic distortion to a percent or less—then the bandwidth just comes along. **R-E**

J. D. RYDER
Professor

Department of Electrical Engineering
Michigan State University
East Lansing, Mich.

In the Shop . . . With Jack

By JACK DARR

Calibrate for Peak-to-Peak volts

A scope is a *comparison* instrument—you need some kind of standard or known voltage. You then compare the pattern amplitude with the amplitude of the standard. In TV service, you compare the p-p pattern amplitude to that given on the schematic. You also compare the wave-shape, but we're only talking about p-p voltages at the moment.

To read p-p voltage, feed in a *known* voltage and set the vertical-gain control of the scope to show a pattern of a certain height. Then you know a pattern of the same height is at the same p-p voltage. You can then go to the TV set and read any p-p voltage you want by comparing it to the known standard voltage.

For example, Fig. 1 shows a scope screen with a vertical line on it set for an amplitude of 4 inches. You get this by turning the horizontal gain all the way off. (It's easier to read, and there are other advantages, as we'll see in a minute.) Let's say we want to read a horizontal output tube's grid-drive signal. The schematic says it should be 175 volts p-p.

Let's feed in an ac voltage at 200 volts p-p, and adjust the vertical gain to make a 4-inch line. Now each of the thick lines is 50 volts p-p. If your scope doesn't have the lines on the graticule, you can mark the dis-

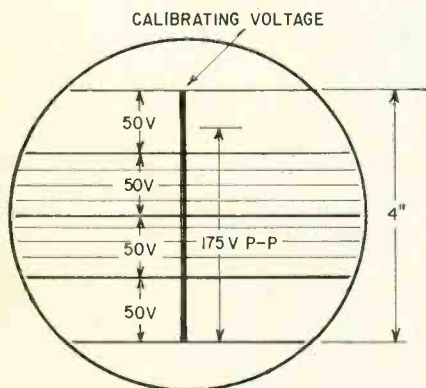

Fig. 1

tance on the screen with a grease-pencil and divide it into four equal parts. Half the distance (2 inches) is 100 volts p-p; 3/4 of the distance is 150 volts p-p, and so on.

APRIL 1969

"Yeah," somebody says, "but I haven't got a source of 200 volts peak to peak!" Care to bet? All you need is an ac voltage. First read it with a fairly good ac voltmeter, then multiply this voltage (an rms value) by 2.8, which will give you p-p.

You can get a 200-volt p-p calibration by using the 70-volt filament setting on a tube tester. (If you want to be precise about it, 71.5 volts rms = 200 volts p-p.) You do *not* need a very accurate reading in most cases. In the grid-drive measurement, we need to know: "Is there *enough* grid-drive signal here?" Or, "Is this signal *at least* 175 volts p-p?"

This can be done. Calibrate the scope on the 70-volt setting, 200 volts p-p. Now move the probe over to the grid of the 6JS6 or whatever it is. The only thing you must *not* do is change the *vertical gain* setting of the scope. Look at the amplitude of the drive signal. You should have a vertical line (even with the bottom calibration mark) that comes up about halfway between the last two marks, or the 150- and 200-volt lines. You can move the vertical *centering* control to make the bottom end of the line sit on the mark.

Most readings don't have to be *too* accurate. You don't have to know whether the grid-drive voltage is 175 volts p-p or 176 volts. You must know, "Is it 175 volts, or less than 100 volts, etc.?" This would be far enough out of the ballpark to cause trouble, and you'd go back to the horizontal oscillator.

Your tube tester is a good source of calibration voltage. For instance, the 5-volt filament setting is very close to 14 volts p-p; 10 volts is 28.2 volts p-p, and so on. You can plug a tube-socket test adapter into one of the tube-check sockets, and hook the scope to the filament terminals. Use an octal adapter, for example, and set the tube tester for a 6V6, etc. The filaments will then be connected to pins 2 and 7.

Can you use a low-capacitance probe on the scope and get the same results? Sure. Just put the probe on the scope, and use it when you make

Circle 18 on reader service card

FIRST AND ONLY compact Scruiox® screwdriver sets

Increasing use of Scruiox square recess screws in appliances, radios, TV sets, electronic instruments... even the control tower at Cape Kennedy... has created a need. A need for compact, versatile driver sets. Small enough to tuck in a pocket. Complete enough to be practical on shop bench or assembly line.

Now, here they are . . . from Xcelite, of course.



PS44
COMPACT
CONVERTIBLE SET

Five color coded midget Scruiox drivers—#00 thru #3

One midget nutdriver—1/4" hex "Piggyback" torque amplifier handle increases reach and driving power

See-thru plastic case doubles as bench stand



99SL
INTERCHANGEABLE
BLADE KIT

Five Scruiox blades—#00 thru #3 Shockproof, breakproof, Service Master handle Durable, see-thru plastic case



XCELITE, INC., 10 BANK ST., ORCHARD PARK, N. Y.
In Canada, contact Charles W. Pointon, Ltd.

10 Reasons why RCA Home Training is your best investment for a rewarding career in electronics:

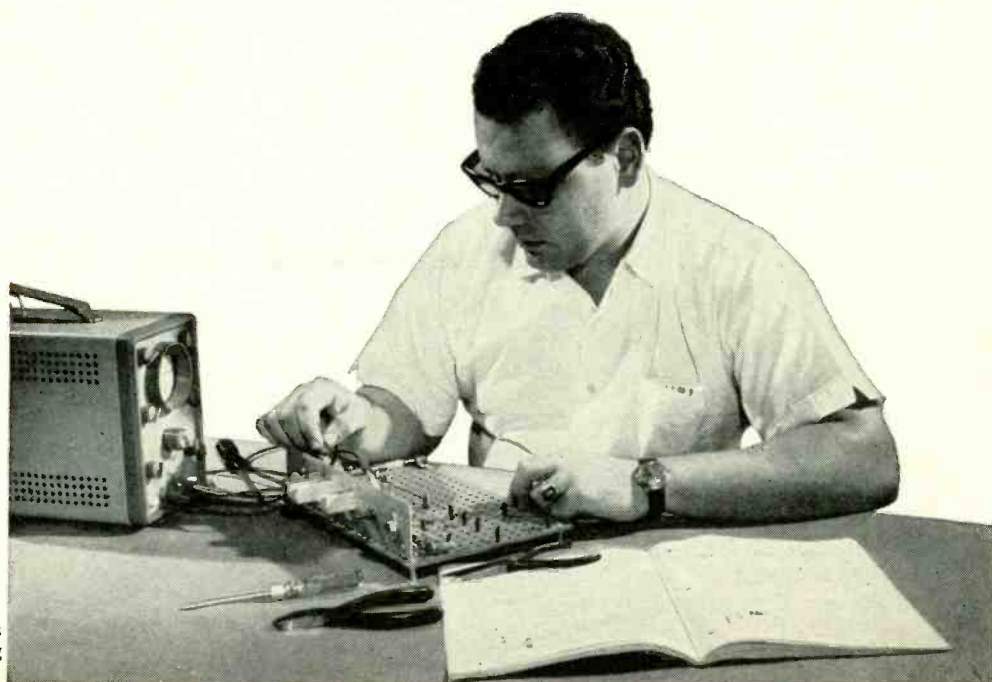

Performing transistor experiments on programmed breadboard—using oscilloscope.

1 LEADER IN ELECTRONICS TRAINING

When you think of electronics, you immediately think of RCA...a name that stands for dependability, integrity and pioneering scientific advances. For over a half century, RCA Institutes, Inc., a service of Radio Corporation of America, has been a leader in technical training.

2 RCA AUTOTEXT TEACHES ELECTRONICS FASTER, EASIER, ALMOST AUTOMATICALLY

Beginner or refresher, AUTOTEXT, RCA Institutes' own method of programmed Home Training will help you learn electronics more quickly and with less effort, even if you've had trouble with conventional learning methods in the past.

3 THOUSANDS OF WELL PAID JOBS ARE NOW OPEN TO MEN SKILLED IN ELECTRONICS

RCA Institutes is doing something positive to help men with an interest in electronics to qualify for rewarding jobs in this fascinating field. Every year, literally thousands of high paying jobs in electronics go unfilled just because not enough men take the opportunity to train themselves for these openings.

4 WIDE CHOICE OF CAREER PROGRAMS

Start today on the electronics career of your choice. On the attached card is a list of "Career Programs", each of which starts with the amazing AUTOTEXT method of programmed instruction. Look the list over, pick the one best suited to you and check it off on the card.

5 SPECIALIZED ADVANCED TRAINING

For those already working in electronics or with previous training, RCA Institutes offers advanced courses. You can start on a higher level without wasting time on work you already know.

6 PERSONAL SUPERVISION THROUGHOUT

All during your program of home study, your training is supervised by RCA Institutes experts who become personally involved in your efforts and help you over any "rough spots" that may develop.

7 VARIETY OF KITS YOURS TO KEEP

To give practical application to your studies, a variety of valuable RCA Institutes engineered kits are included in your program. Each kit is complete in itself. You never have to take apart one piece to build another. At no extra cost, they're yours to keep and use on the job.

8 FROM RCA INSTITUTES TRANSISTORIZED TV KIT, VALUABLE OSCILLOSCOPE

Those enrolled in RCA's television course or program receive complete transistorized TV Kit. All students receive a valuable oscilloscope—both at no extra cost and only from RCA Institutes.

9 CONVENIENT PAYMENT PLANS

RCA Institutes offers a unique tuition plan that lets you progress at your own pace. You only pay for lessons as you order them. You don't sign a contract obligating you to continue the course. There's no large down-payment to lose if you decide not to continue.

However, if you desire, RCA Institutes also offers a convenient monthly payment plan.

10 RCA INSTITUTES GRADUATES GET TOP RECOGNITION

Thousands of graduates of RCA Institutes are now working for leaders in the electronics field; many others have their own profitable businesses. This record is proof of the high quality of RCA Institutes' training.

CLASSROOM TRAINING ALSO AVAILABLE

If you prefer, you can attend classes at RCA Institutes Resident School, one of the largest of its kind in New York City. Coeducational classroom and laboratory training, day and evening sessions, start four times a year. Simply check "Classroom Training" on the attached card for full information.

JOB PLACEMENT SERVICE, TOO!

Companies like IBM, Bell Telephone Labs, GE, RCA, Xerox, Honeywell, Grumman, Westinghouse, and major Radio and TV Networks have regularly employed graduates through RCA Institutes' own placement service.

SEND ATTACHED POSTAGE PAID CARD TODAY! FREE DESCRIPTIVE BOOK YOURS WITHOUT OBLIGATION! NO SALESMAN WILL CALL!

All RCA Institutes courses and programs are approved for veterans under the New G.I. Bill.

RCA INSTITUTES, DEPT. RE-49
320 West 31st Street,
New York, N.Y. 10001

Accredited Member National Home Study Council

RCA

Construction of Multimeter.

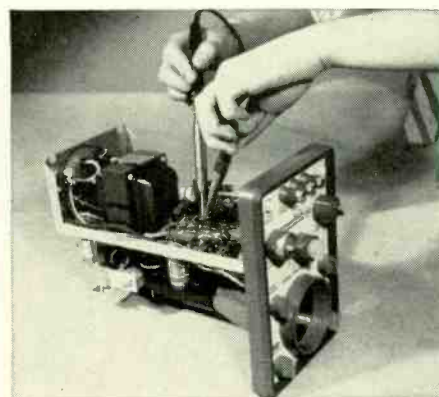

Construction of Oscilloscope.

Temperature experiment with transistors.

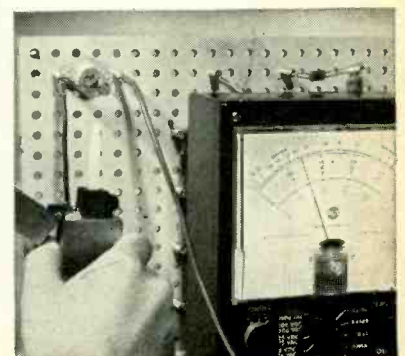

SAMS BOOKS for every electronics interest

NEWLY PUBLISHED AND IMPORTANT!

Transistor Substitution Handbook. 9th Ed.

Fully updated. Lists thousands of direct substitutions; includes basing diagrams and polarity indications. Covers manufacturers of all transistor types, providing substitutions for U. S. and foreign home entertainment, industrial and military types. In addition to the substitutions which have been computer-selected, the book also includes manufacturers' own substitution recommendations for their general-purpose types. A comprehensive reference.
Order 20705, only.....\$1.95

Symfact® Guide to Color TV Servicing

If you have experienced problems in servicing color-TV receivers, this book will show you the right, time-saving repair approach. Describes not only the best techniques to use, but also explains normal operation and the designs of various circuits. Each section of the book provides complete full color picture tube symptom analysis, waveforms, voltage and component analysis, and your best bet in the use of the proper equipment to pinpoint trouble sources.
Order 20710, only.....\$3.50

Using Scopes in Color TV

This book concentrates on chroma-circuit waveform analysis and interpretation of special patterns, such as vectorgrams. Begins with a description of oscilloscope requirements, and explains how a narrow-band scope can be used to make certain tests of wide-band circuit action. Professional technicians will find this book, with its emphasis on color-waveform analysis, an invaluable supplement to their present general knowledge about color-TV troubleshooting.
Order 20718, only.....\$3.95

Electronic Circuit Design

This book relates the basic theories of electronics to the required components and their ratings. It is invaluable as a study and reference guide, and a great help in the proper performance of build-it-yourself projects. The basic analysis of electronic design serves as an excellent refresher, and is most informative for students. It will also enable the experimenter to undertake projects that go beyond the usual type of construction kits.
Order 20699, only.....\$3.95

RECENT AND TIMELY BESTSELLERS

Color-TV Servicing Guide

Shows how to apply fast troubleshooting procedures, based on analysis of trouble symptoms. Includes full-color picture tube photos showing various operating troubles; clearly explains how to diagnose trouble causes; gives repair procedures. Order 20358, only.....\$4.25

Transistor-TV Servicing Guide. 2nd Ed.

Updated to provide full information on latest circuitry and many additional new test procedures. Covers general transistor circuitry and servicing techniques; then proceeds through the receiver, section by section, describing various picture and/or sound trouble symptoms.
Order 20696, only.....\$3.95

NEW 5TH EDITION OF THE WORLD-FAMOUS Reference Data for Radio Engineers

Now contains 50% more data to cover the developments of the past 12 years. Prepared by outstanding engineers, professors, and experts, under the direction of the International Telephone and Telegraph Corporation staff. Provides comprehensive data on all basic phases of electronics, including tables, formulas, standards, and circuit information—PLUS—all-new data on micro-miniature electronics, navigation aids, reliability and life testing, international telecommunication recommendations, switching networks and traffic concepts, and quantum electronics. Over 1350 illustrations. 1138 pages. Order 20678, only.....\$20.00

Semiconductor Handbook

Here, in one comprehensive heavily illustrated volume, is the most complete, modern sourcebook for industrial semiconductor data. Covers latest circuitry in a wide variety of applications; provides full data on industrial semiconductors, including grown-junction, alloyed-junction, drift, MADT, mesa, planar, and epitaxial mesa types.
Order 20620, only.....\$5.75

Television Service Training Manual. 2nd Ed.

Updated and expanded to include new TV servicing short cuts and tests. Shows how to use test points to isolate trouble to specific components, in both tube and transistor receivers. Treats all sections of the TV receiver; packed with schematics, charts, and drawings. Provides you with quick, sure-fire analysis and repair procedures. Order 20628, only.....\$4.95

Practical Transistor Servicing. 2nd Ed.

Provides fastest, most direct methods for troubleshooting all types of transistorized equipment, including FM and auto radios.
Order 20314, only.....\$4.25

AM-FM-TV Alignment

Here is all you need to know about alignment of all radio and tv sets. Includes chapter on audio amplifier frequency-response checks.
Order 20602, only.....\$3.95

Troubleshooting with the Oscilloscope.

Shows practical use of the scope to isolate circuit troubles. Tells how to setup for tests, how to use probes, how to interpret waveforms, how to troubleshoot. Order 20550, only.....\$4.50

Troubleshooting Audio Equipment

Analyzes amplifier and preamp circuitry. Explains how to diagnose and repair malfunctions. Also covers pickups, microphones, tape recorders, and stereo systems.
Order 20525, only.....\$3.95

More Bestselling Sams Titles

Tube Substitution Handbook. 12th Ed.
Order 20700, Shop Edition, only.....\$1.75
Troubleshooting with the VOM and VTVM
Order 20481, only.....\$3.95
Closed Circuit TV for Engineers & Technicians
Order 20606, hardbound, only.....\$8.95
101 Questions & Answers About CATV & MATV
Order 20655, only.....\$2.50

HOWARD W. SAMS & CO., INC.

Order from any Electronic Parts Distributor, or mail to Howard W. Sams & Co., Inc., Dept. RE-4
4300 W. 62nd St., Indianapolis, Ind. 46268

Send books checked at right. \$_____enclosed.

Send FREE 1969 Sams Book Catalog

Name _____
PLEASE PRINT

Address _____

City _____ State _____ Zip _____

- | | |
|--------------------------------|--------------------------------|
| <input type="checkbox"/> 20705 | <input type="checkbox"/> 20314 |
| <input type="checkbox"/> 20710 | <input type="checkbox"/> 20602 |
| <input type="checkbox"/> 20718 | <input type="checkbox"/> 20550 |
| <input type="checkbox"/> 20699 | <input type="checkbox"/> 20525 |
| <input type="checkbox"/> 20358 | <input type="checkbox"/> 20700 |
| <input type="checkbox"/> 20696 | <input type="checkbox"/> 20481 |
| <input type="checkbox"/> 20678 | <input type="checkbox"/> 20606 |
| <input type="checkbox"/> 20620 | <input type="checkbox"/> 20655 |
| <input type="checkbox"/> 20628 | |

Circle 22 on reader service card

IN THE SHOP

(continued from page 17)

the calibration. Touch the probe tip to the filament connections, set the gain control for the line height you want and there you are. Here's what you have: A 10-volt p-p signal at the probe tip makes a 2-inch, 3-inch, etc. vertical line on the screen. So, any 10-volt p-p signal at the probe tip will make a line of the same length on the screen. You don't have to worry about the probe's voltage-divider action, etc.

Cutting the horizontal gain to zero makes the scope easier to read, and helps in other ways. If you have a waveform with a long, thin spike like Fig. 2 on it, you may not even see it. It's so thin and fast that it makes a very weak trace. By cutting the horizontal sweep, the spike is

YOU MAY NOT SEE THESE
UNTIL YOU CUT THE HORIZONTAL GAIN

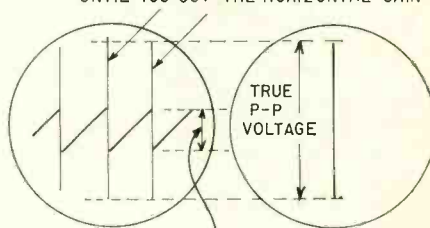

APPARENT P-P VOLTS
Fig. 2

scanned repeatedly, and becomes bright enough to see easily. This will show up spike and pulse waveforms that can otherwise be hard to read accurately. You might think the sawtooth part of the wave in Fig. 2 was the actual p-p voltage, but the spikes are at least three times higher.

You shouldn't touch the vertical gain control—the continuously variable control. If your scope has a step control ($\times 1$, $\times 10$, and $\times 100$), as most do, you can use this as a divider. For instance, set it to $\times 1$, apply a 100-volt p-p signal and calibrate for a 4-inch deflection (or whatever you want). Then by turning the step control to $\times 10$ (increasing the gain of the vertical amplifier 10 times), you will be able to read the same deflection for a 10-volt p-p signal. Going on up to $\times 100$, you'll see the same deflection for a 1-volt p-p signal.

This works in the opposite direction, too. For example, if you want to read a 1000-volt p-p pulse and you have a 10-volt p-p calibrating voltage, set the step control on the $\times 100$ (highest gain) range. Now $\times 10$ will read 100 volts and $\times 1$ will read 1000 volts for the same deflection. You've reduced the gain of the vertical amplifier by 10 or 100. To keep from getting confused on how this works, try it on the calibrating voltage. **R-E**

This is not a construction article. However, if you would like to see a complete "Build-It" story on this project drop a card to the editor. If readers show enough interest we will ask Mr. Plavcan to prepare an article with complete construction details for you.

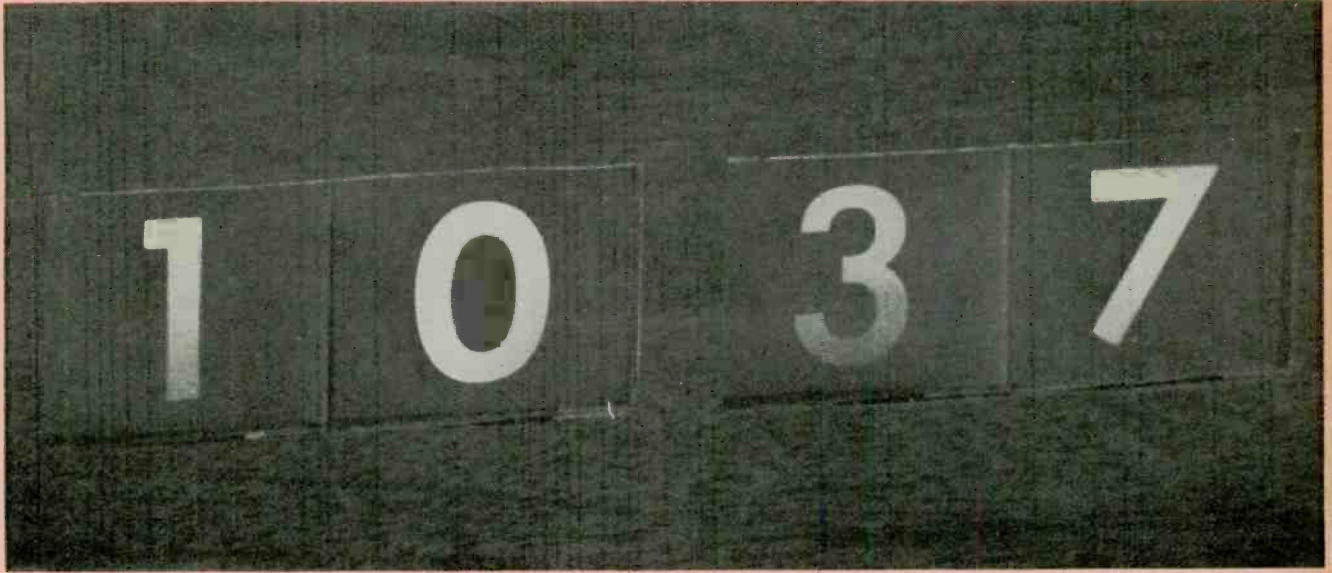

A \$200 IC DIGITAL CLOCK

IC's and numerical readouts combine to make a digital clock

by A. B. PLAVCAN

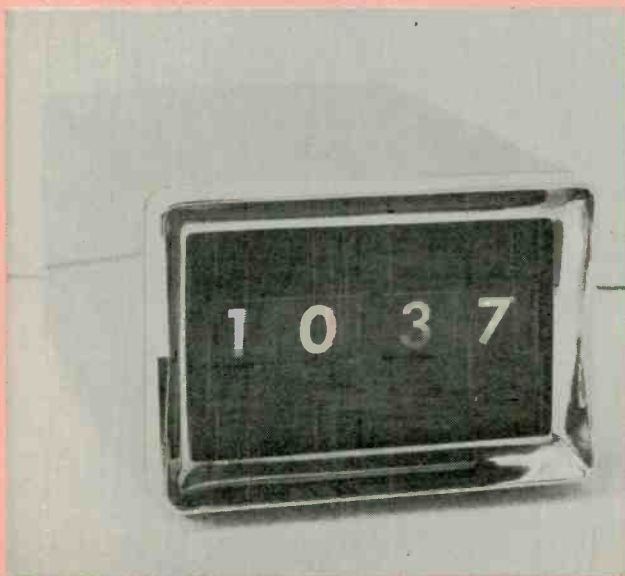

INTEGRATED CIRCUITS, LONG A LUXURY OF THE MILITARY, are rapidly finding their way into consumer oriented products. Prices have dropped within the reach of the average builder and experimenter. Here's a tale of how I've used these IC's (integrated circuits) to build a digital electronic clock.

This clock is designed around SN7492 IC counters (made by Texas Instruments) and diode transistor logic. It is a standard 12-hour clock that uses the 60-Hz line frequency as its main timing source. It features 115-volt ac operation, compact design, low current drain (less than 100-ma on the 115-volt line), and simple time set.

The layout is rather straightforward and not critical. The redundant circuitry lends itself well to printed-circuit techniques. I used sockets for the IC's to allow for easy replacement (should it become necessary) and as an aid to troubleshooting. Low-cost 2N5183 transistors are used wherever possible to keep costs down.

Operation is relatively simple. The 60-Hz line frequency is divided in IC1 and IC2 to 1 Hz (Fig. 1). This then becomes the reference count for all future timing. It

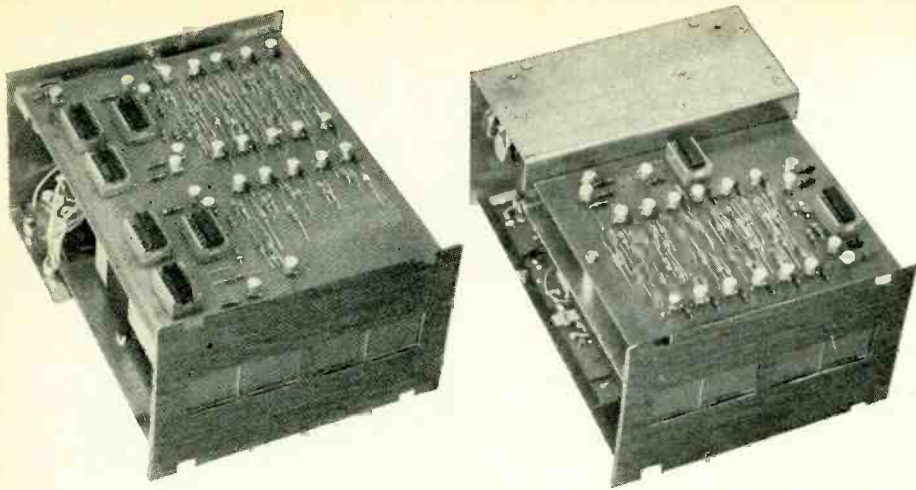

Inside the clock case. Two circuit cards carry most of the components. Space is tight, but a little planned cramming makes it all fit nicely. IC's are all in sockets to make replacement, if necessary, easy.

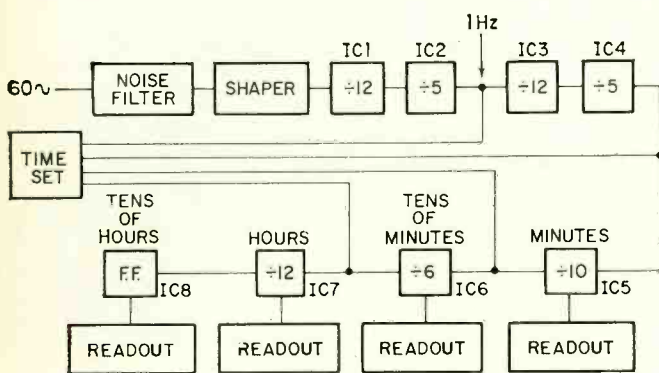

Fig. 1—Basic block diagram of the clock. It shows the order in which signals from the 60-Hz line are turned into timing pulses that operate the readout modules.

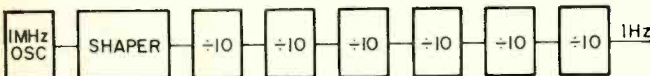

Fig. 2—For more accurate timing use a 1-MHz crystal oscillator and divide its signal down to tell time.

is further divided to produce the minutes and hours in the readout. Time accuracy is dependent on line-frequency stability. If greater accuracy is desired, additional IC's can be added as shown in the block diagram of Fig. 2. If this is done, divide-by-ten units must be used.

With the crystal-controlled 1-MHz oscillator shown in Fig. 2, the clock will be accurate to about 30 parts-per-million. This should be more than ample.

The 60-Hz signal input (Fig. 2) passes through a noise filter to prevent line noise, motors, switch transients, etc. from triggering the input divider. The signal then goes on to the shaper circuit (Fig. 4). The $0.1 \mu\text{F}$ capacitor across the 10,000-ohm resistor is a "speed-up" capacitor. It decreases the rise time of the leading edge (which becomes the trailing edge on the output) to provide better triggering for the divider. The diode clips the negative peaks of the sine wave to prevent V_{BE} breakdown. The shaped signal is now ready to divide down.

If SN7492 IC's are not available, SN7493 four-bit binary counters can be used instead. Basic operation is as follows.

If the reset lines (pins 2 and 3) are grounded, the counter will divide-by-16 (Pins 1 and 12 must be jumpered.), since each flip-flop divides-by-two and there are four flip-flops with no reset to inhibit the count (2^n where n is the number of flip-flops). But we're not interested in dividing by 16. We want to divide by 5, 6, 10, or 12. We can force this counter to divide by any of these numbers very easily. We'll need a truth table to do this. A truth table simply tells us the state of each flip-flop after each count.

Let's say we want to divide-by-five. The truth table (Fig. 9) shows us that after the fifth count, output "A" is high (1), output "B" is low (0), output "C" is high (1) and output "D" is low (0). Our four-bit binary requires both reset lines (pins 2 and 3) to be high (1) to reset to zero. We see that output "A" and output "C" are high (1). So if we connect output "A" (pin 12) to pin 2 and output "C" (pin 8) to pin 3, the counter will divide by five. When the count reaches five, the counter will reset to zero and repeat the count. Follow the same procedure for the other dividers. The SN7492 IC's I used follow the same procedure, even though the truth table (Fig. 8) is a little different. You'll notice that the four-bit binary consists of four J-K flip-flops and a NAND gate (NOT AND). If you took two SN7493 IC's and added a NAND gate as shown it will perform the same function as the SN7493 four-bit binary. You can also use separate J-K flip-flops and build up the dividers. The divide-by-five and divide-by-six require only three flip-flops each. Follow the same procedure as above. One advantage of the SN7493 is that the \bar{Q} function is

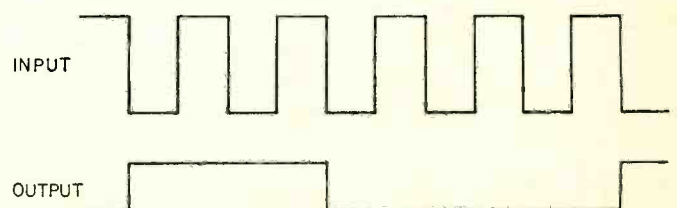

Fig. 3—This is what you'll see on a scope screen if you look at divide-by-six. Negative pulse triggers flip-flop.

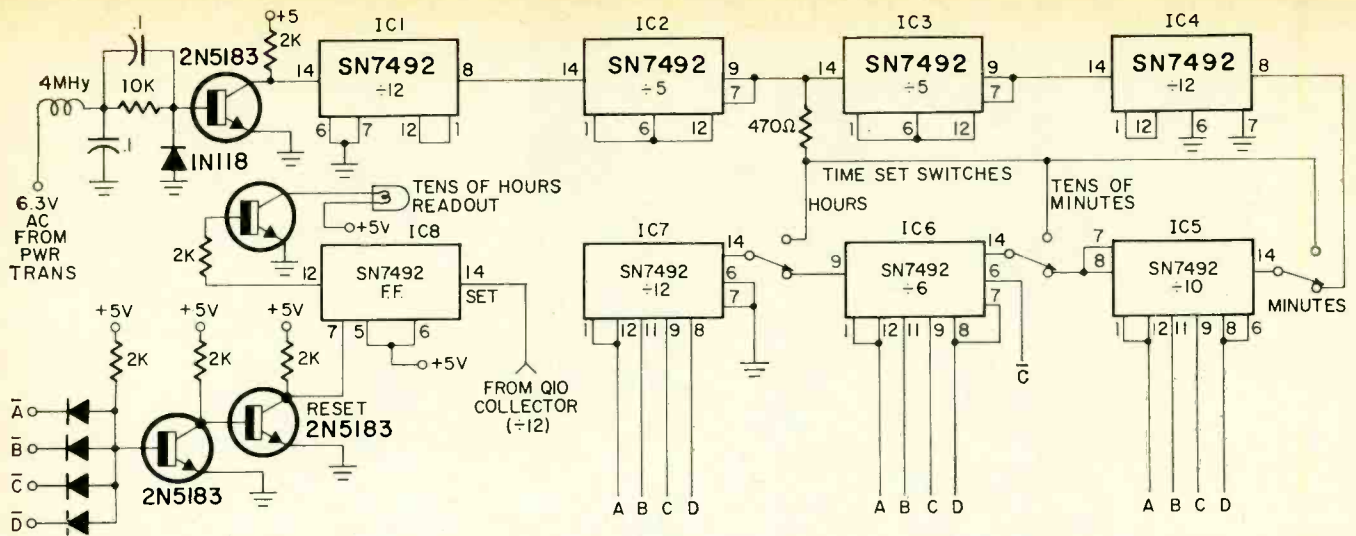

Fig. 4—Here we have the major portion of the clock circuits. All labeled circuit lines in this Figure connect to the matching points in Figures 5-a, and 5-b.

brought out to a terminal. You can eliminate all the inverters that are required for the SN7492 and connect instead to the Q terminals.

I used printed circuitry for all of the layout. Cop-perclad board is readily available at reasonable prices. I suggest you use masking tape to lay out the work instead of the dry-transfer material available. It tends to work a bit easier for the beginner. Use large ground areas in your layout too. Masking the layout is a little tedious, but the results are worth the effort. It eliminates a jungle of crossing wires and is easier to service.

After your printed-circuit boards are ready, it's time to start mounting the parts. Before you start, I suggest you check all parts electrically. A bad diode can cause an awful lot of unnecessary troubleshooting.

If you do end up with a troubleshooting problem, a scope and signal generator are musts. Simply insert a 1-MHz signal in place of the 60-Hz input. The scope can now be used to check each divider counter. Sync the

Fig. 5-a—(below) Details of typical inverter and read-outs are depicted here. Fig. 5-b (right) is the diode-transistor logic to operate readouts. Like points interconnect.

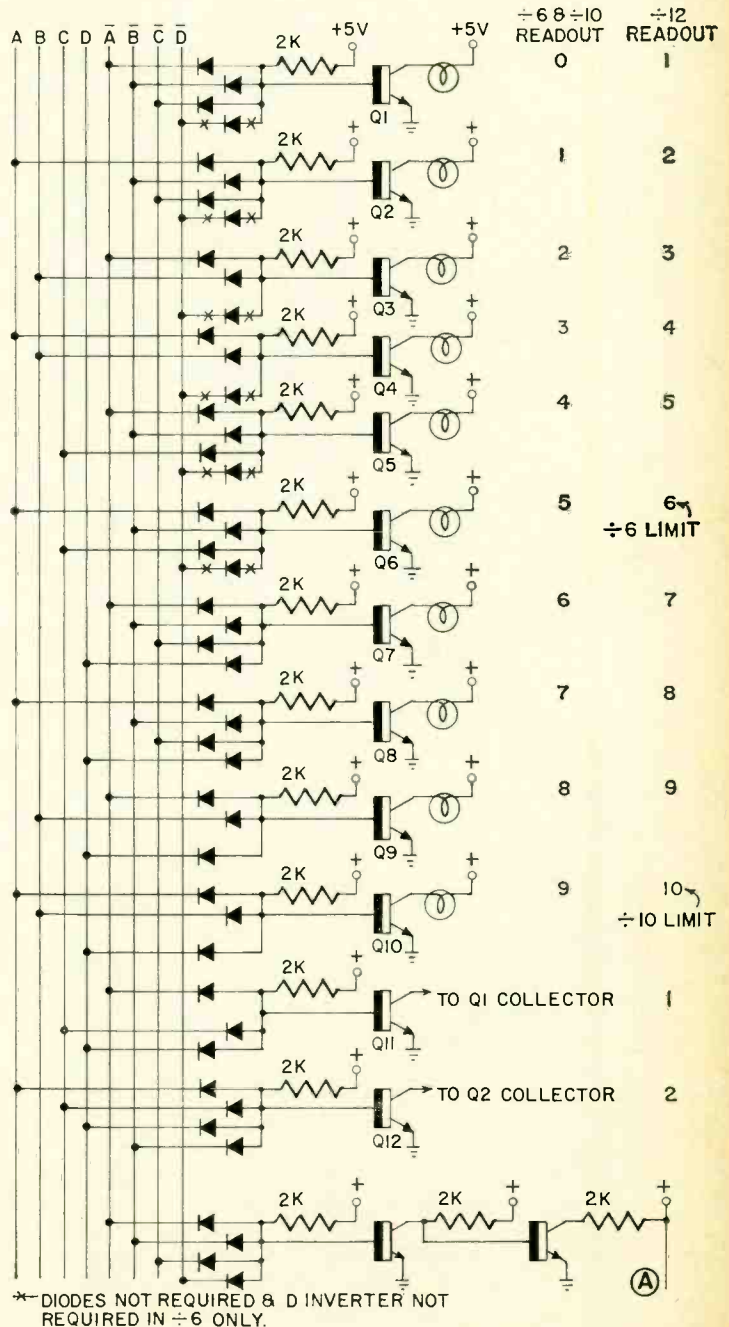
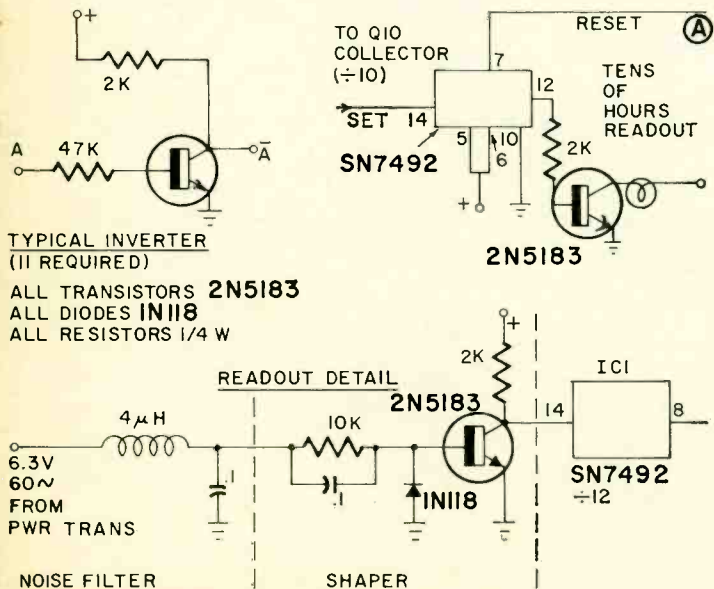

*DIODES NOT REQUIRED & D INVERTER NOT REQUIRED IN ÷6 ONLY.

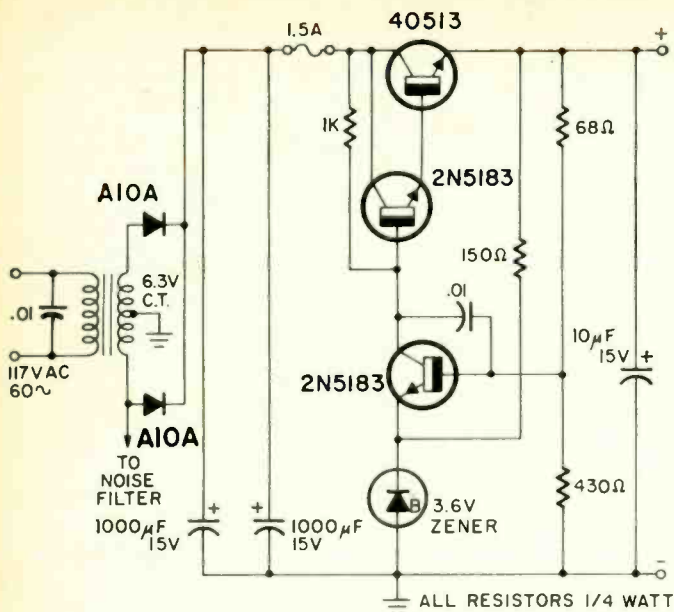

Fig. 6—(left) A simple power supply delivers 5-volts at 1 ampere to power the clock. Fig. 8—(right) is the Truth Table for the SN7492 IC.

SN7492				
TRUTH TABLE				
COUNT	A	B	C	D
0	0	0	0	0
1	0	0	0	1
2	0	0	1	0
3	0	0	1	1
4	0	1	0	0
5	0	1	0	1
6	1	0	0	0
7	1	0	0	1
8	1	0	1	0
9	1	0	1	1
10	1	1	0	0
11	1	1	0	1

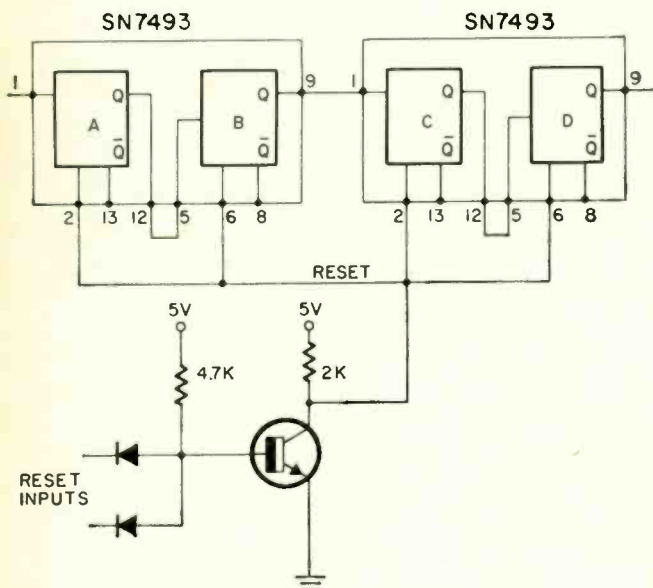

Fig. 7—(left) Details hook-up for using SN7493 binary counters. Fig. 9—(right) is the Truth Table for the SN-7493 IC's.

SN7493				
FOUR BIT BINARY COUNTER				
TRUTH TABLE				
JUMPER PIN 1 AND 12				
OUTPUT				
COUNT	D	C	B	A
0	0	0	0	0
1	0	0	0	1
2	0	0	1	0
3	0	0	1	1
4	0	1	0	0
5	0	1	0	1
6	0	1	1	0
7	0	1	1	1
8	1	0	0	0
9	1	0	0	1
10	1	0	1	0
11	1	0	1	1
12	1	1	0	0
13	1	1	0	1
14	1	1	1	0
15	1	1	1	1

scope externally on the output of the counter under test (see Fig. 3).

The readout decoding follows the truth table (Fig. 8) and uses simple germanium diode-transistor logic to reduce the circuitry and cost. With germanium diodes and silicon transistors, if any diode input is grounded the transistor is off. All diode inputs must be high for the transistor to turn on. A 0.3-volt (typical) voltage differential exists between diode on and transistor off. This noise immunity is similar to the counters.

The 5.0-volt power supply shown in Fig. 6 is more than adequate to power the clock. It has a low ripple and good regulation to provide uniform illumination of the readouts and stable power for the IC's. The 6.3-volt readout bulbs work very well with 5.0 volts. Also, the reduced voltage insures longer bulb life. Use a good heat sink on the power pass transistor.

I used Texas-Instruments SN7492 divide-by-twelve IC counters throughout. They were purchased at a third of their usual cost from an electronic surplus store. But close examination will show that other divide-by count-

ers could also be used. For example, divide-by-ten counters can be substituted and "strapped" to divide-by-five, divide-by-six, divide-by-ten. The only exception is IC7. It must be a divide-by-twelve in this particular design. IC8 need only be a set-reset flip-flop.

Another saving can be realized in the readout. The ones shown are made by Industrial Electronic Engineers of Van Nuys, Calif., and are fairly expensive. Radio-Shack has an edge-lighted unit that will work equally well.

The time set switches are the "make-before-break" type. This is a must to eliminate switching transients from false triggering while setting the time. Rotary switches were used, since pushbutton make-before-break are not available.

To set the time after turning the clock on, let each readout run a complete cycle with the time-set switches to clear each counter. Then set the time.

IC's are here to stay, at least for a little while. Here's your chance to get familiar with them and have a useful timepiece for years to come.

R-E

KENWOOD receivers offer you THREE WAYS TO IMPROVE YOUR HEARING ...TK-88, TK-66 and TK-55

Even speech sounds crisp, clear and natural. And music really comes alive because KENWOOD solid state receivers reproduce exactly the original material.

Each of these KENWOOD stereo receivers is a magnificent instrument with the most advanced engineering features. Compare them with others for specifications, performance and value. Each KENWOOD receiver is known the world over for dependability, reliability and quality.

There never will be a better time than now to improve your hearing. Sound test these KENWOOD receivers at your nearest KENWOOD franchised dealer... and decide which one is best for you.

(shown from top to bottom)

KENWOOD TK-88... FET, solid state, FM/AM, 90-watt stereo receiver

KENWOOD TK-66... FET, solid state, FM/AM, 60-watt stereo receiver

KENWOOD TK-55... FET, solid state, FM only, 60-watt stereo receiver



the sound approach to quality



1700 S. Broadway Pl., Los Angeles, Calif. 90007
69-41 Calanus Ave. Woodside, N. Y. 11377
Exclusive Canadian Distr. — Perfect Mfg. & Supplies Corp. Ltd.

**“He’s a good worker.
I’d promote him
right now if he had
more education
in electronics.”**

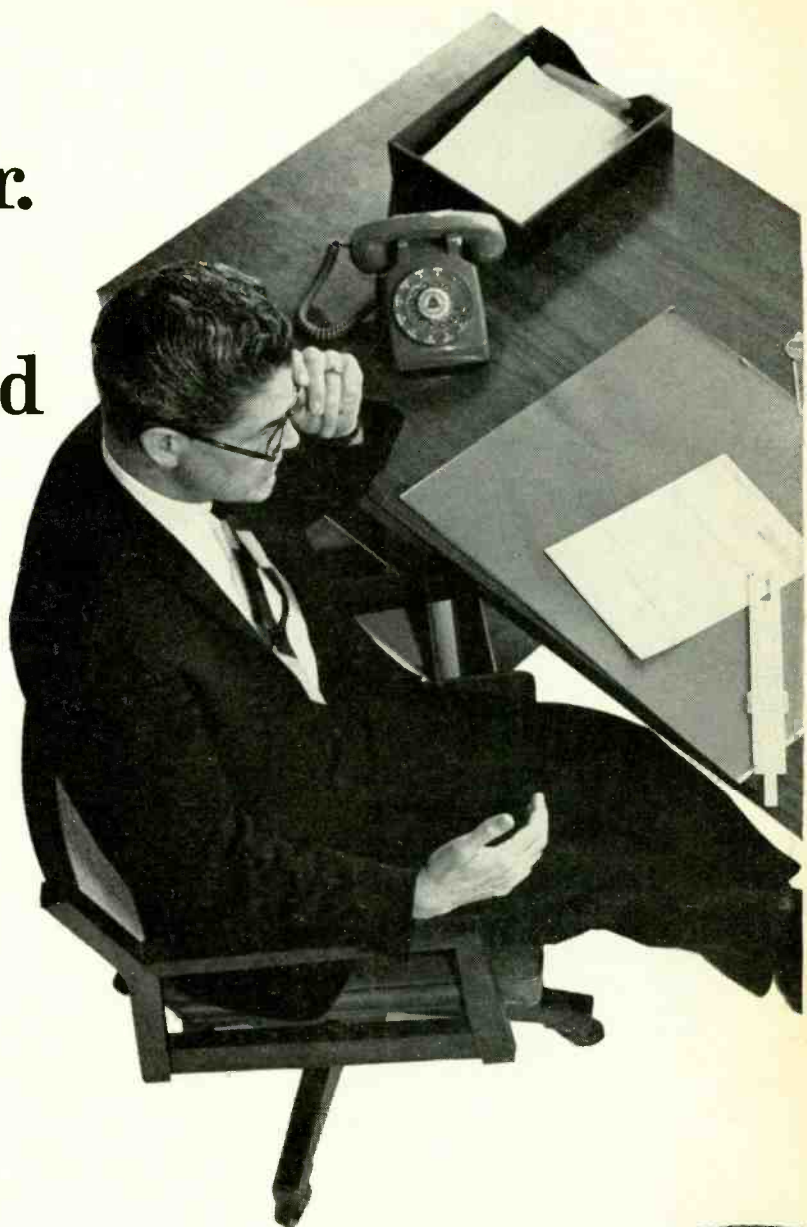

Could they be talking about you?

You'll miss a lot of opportunities if you try to get along in the electronics industry without an advanced education. Many doors will be closed to you, and no amount of hard work will open them.

But you can build a rewarding career if you supplement your experience with specialized knowledge of one of the key areas of electronics. As a specialist, you will enjoy security, excellent pay, and the kind of future you want for yourself and your family.

Going back to school isn't easy for a man with a

full-time job and family obligations. But CREI Home Study Programs make it possible for you to get the additional education you need without attending classes. You study at home, at your own pace, on your own schedule. You study with the assurance that what you learn can be applied to the job immediately.

CREI Programs cover all important areas of electronics including communications, radar and sonar, even missile and spacecraft guidance. You're sure to find a program that fits your career objectives.



NEW!
 Expanded coverage of solid state electronics including integrated circuits!

You're eligible for a CREI Program if you work in electronics and have a high school education. Our FREE book gives complete information. Mail postpaid card for your copy. If card is detached, use coupon at right or write: CREI, Dept. 1404 H, 3224 16th St., N.W., Washington, D.C. 20010.



**CREI, Home Study Division
 McGraw-Hill Book Company
 Dept. 1404H, 3224 Sixteenth Street, N.W.
 Washington, D.C. 20010**

Please send me FREE book describing CREI Programs. I am employed in electronics and have a high school education.

NAME _____ AGE _____

ADDRESS _____

CITY _____ STATE _____ ZIP CODE _____

EMPLOYED BY _____

TYPE OF PRESENT WORK _____ G.I. BILL

I am interested in Electronic Engineering Technology
 Space Electronics Nuclear Engineering Technology
 NEW! Digital Communications

APPROVED FOR TRAINING UNDER NEW G.I. BILL

GET BETTER PERFORMANCE

Add Electronic Ignition

by BENNETT C. GOLDBERG & RAYMOND G. WILKINS

DURING RECENT YEARS A NUMBER of articles have appeared describing transistorized automobile ignition systems. The majority of these systems (manufactured units and construction projects) had malfunctions after a few thousand miles of engine use due to exceeding germanium power transistor capabilities and poorly designed circuits.

The detrimental effects on germanium transistors occur with continuous operation at junction temperatures of 100°C. Temperatures in the engine compartment can range from +70° to +110°C or higher on hot summer days.

Silicon transistors

To beat the temperature problem, two transistor ignition systems were developed: a negative-ground system for American automobiles, and a positive-ground system for some foreign automobiles. A reliable high-voltage silicon power-switching transistor, having excellent beta with large collector currents at cold and hot temperature extremes, was selected. Silicon transistors have fast switching times and a junction temperature range in excess of +125°C with the proper heat sink.

These units were "worst case" designed for high reliability and laboratory-tested at ambient temperatures -55° to +125°C.

The negative-ground system has been in operation in a 1963 6-cylinder 85-h.p. Ford Falcon and a 1965 8-cylinder 325-h.p. Chevrolet. The systems have exceeded 10,000 miles without malfunction.

Circuit operation

On the negative-ground system (Fig. 1), current flows through R3 to the base of Q1 when the ignition breaker points are closed. This saturates the transistor and current flows

through R4 to the base of Q2. Transistor Q2 then saturates and its collector current flows from the +12-volt battery terminal through ballast resistor R1 and transformer T1. Energy equal to $\frac{1}{2} LI^2$ (where L is the inductance of the transformer primary and I is the current flowing in the transformer primary) is stored in the T1's primary.

When the points open, Q1 no longer receives base drive, turning it off, and Q2 is cut off when it loses base drive from R4. Energy is stored in T1's primary until it reaches the breakdown voltage of Zener diode D2. This flux change in the transformer builds up a voltage in the secondary. The secondary voltage is the ignition pulse which jumps the spark plug. Ballast resistor R1 sets the primary current to the required amount. Zener diode D2 limits the voltage across transistor Q2 to a safe 100 volts.

During normal running, the battery is fully charged to 14-15 volts.

Under these conditions, the ballast resistor is set to give a peak coil current of approximately 12 amps. When the car is starting, the battery voltage drops to 8-10 volts because of the starter load. This reduced battery voltage could mean less coil current and therefore a weak spark.

Therefore diode D1 is added to bypass the ballast resistor during engine cranking. This maintains the desired peak coil current and a full spark.

On the positive-ground system (Fig. 2), when the points are closed current flows through R3 to the base of Q1. This saturates the transistor, and current flows through R1, Q1, R4, R5, R6 at the primary of the transformer T1. When the points open the transistor no longer receives base drive. Current flow through the transistor is interrupted, and the operation is the same as the negative-ground system, including R1, D1 and D2.

Construction

The unit is built in a 2½ x 2½ x 5-inch aluminum box. The heat sink for D1, D2, Q1 and Q2 is the outside top of the box (see photo), D1, D2, Q1 and Q2 must be electrically insulated from the heat sink and ground. This is done by mounting the components with their insulating hardware and applying silicone grease on the metal surface. The grease aids in conducting the heat away. Arrangement of the components inside the box is not critical except D2 should be mounted near Q2.

Capacitor C1 (negative-ground system) should be the same value as the capacitor in the distributor next to the ignition breaker points. It may be placed inside the box or at terminal TB-6. The original breaker-point capacitor may be used later after the transistor ballast-resistor R1 is adjusted. This adjustment will be dis-

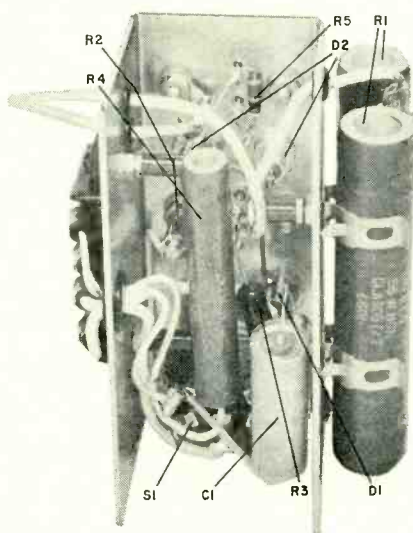

Inside the ignition system there's plenty of room to fit all parts without cramming.

**Silicon transistor ignition system can
give your car a new lease on life—**

To Your Car

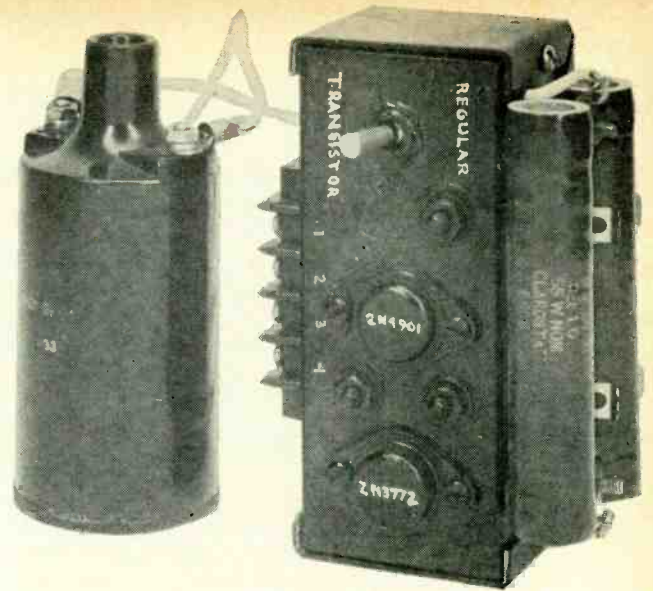

cussed in more detail later.

Do not remove the capacitor in the positive-ground system. The time constant of R3 and the capacitor is small and has little effect on the input trigger pulse.

Ignition coil T1 is mounted on the engine firewall as close to the distributor as possible. Number 14 wire was used in all external wiring to the coil, ignition switch and starter. It is important that good grounds be used and all connections are secure.

The ignition-system package was mounted on the engine firewall. It could be mounted in another convenient location, preferably away from the exhaust manifolds. Tests had indicated it was not necessary to mount the package near the radiator or fan, thus simplifying installation.

The change-over arrangement from a conventional system to the transistor ignition is simple. To operate in the conventional mode, S1 is placed in position 2 and the center high-voltage distributor lead is plugged into the conventional coil. To operate in the transistor mode, place switch S1 to position 1 and plug the center high-voltage distributor lead into the transistor coil.

Here is a seven-step sequence for adjusting your negative ground transistor ignition system:

- With the transistor ignition system bolted to the firewall, connect

PARTS LIST (Negative Ground)

- R1—1-ohm 100-watt adjustable resistor Clarostat VK100NA or equal
- R2—680-ohm 1/2-watt ±10%
- R3—100-ohm 5-watt ±5% Clarostat VPR5F or equal
- R4—10-ohm 20-watt ±5% Clarostat VPR-20H or equal
- R5—47-ohm 1/2-watt ±10%
- C1—22 μF 600-volt ignition-point capacitor (see text)
- CR1—1N1199 50-volt, 12-amp silicon diode
- CR2—1N3005 100-volt, 10-watt Zener diode
- Q1—2N4901 pnp silicon transistor (Motorola)
- Q2—2N3772 npn silicon transistor (RCA)
- T1, S1, MISC—See positive ground
- TO-3 Power Transistors, 2 req.

wires to the positive and negative terminals of the transistor coil (no wires to other terminals).

- Place S1 in position 1.
- Start and run engine with normal ignition system until battery is fully charged. (Note: No connections have yet been made between the car's electrical system and the terminal strip.)

- With the engine running, connect a jumper wire with a 15-amp dc ammeter and ballast-resistor R1 (set to 1 ohm) in series between TB-4 and the positive terminal of the battery.

- Connect TB-5 to ground and adjust ballast-resistor R1 for a current reading of 12 amps. This will set R1 to the correct value,

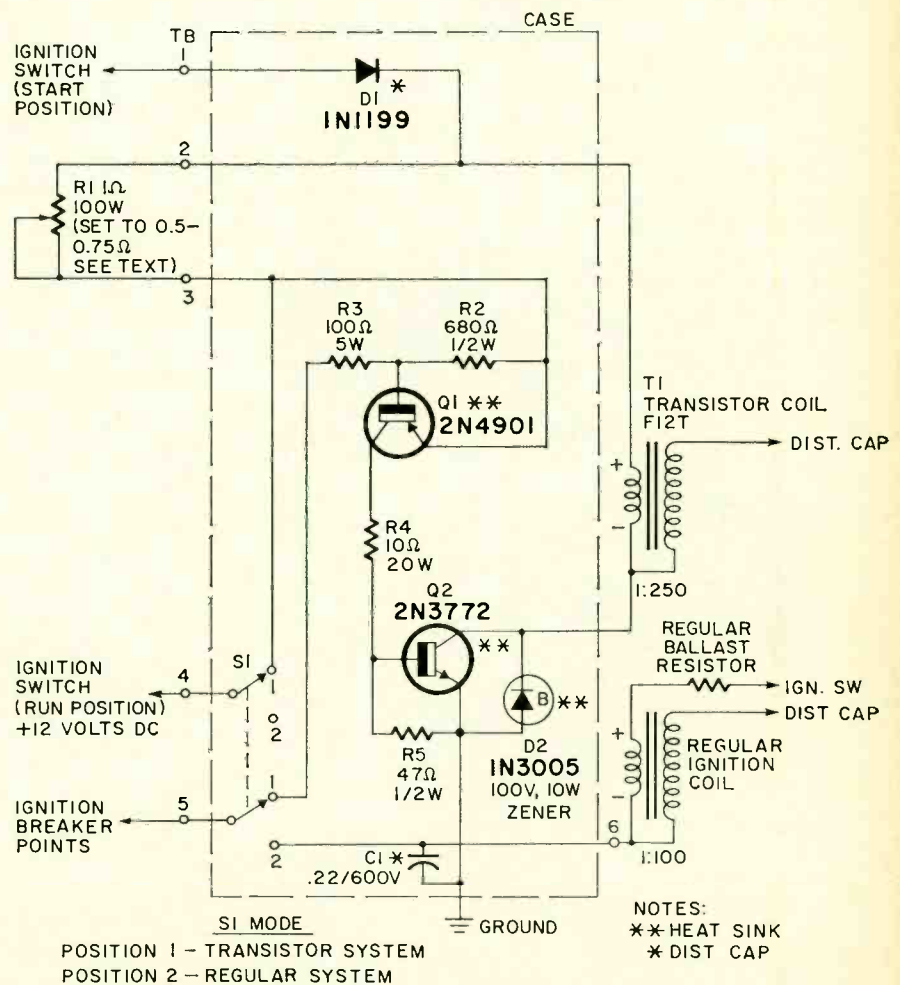

Fig. 1—This circuit is the one to use if you are building an ignition system to use with a negative-ground car. This includes almost all American made automobiles made in recent years. If you have a car with a positive-ground system try the circuit in Fig. 2.

which should be 0.5–0.75 ohm.

- Stop the engine, remove jumpers, etc., and connect wires to all terminals; remove the distributor capacitor (negative system only), and place it in the transistor box or at TB-6.

- Place the center high-voltage lead from the distributor to the transistor coil. Make sure switch S1 is in position 1. Your car will now start and run in the transistor mode.

This is the adjustment procedure for positive-ground systems:

- Bolt the transistor ignition

PARTS LIST (Positive Ground)

- R1—1-ohm 100-watt adjustable Clarostat VK100NA or equal
- R2—47-ohm 1-watt ±10%
- R3—7.5-ohm 5-watt ±5% Clarostat VPR5F or equal
- R4, R5, R6—1-ohm 10-watt ±5% Clarostat VPR10F or equal
- DRI—1N1199, 50-volt, 12 amp silicon diode
- CR2—IN3005 100-volt, 10-watt Zener diode
- Q1—2N3772 npn silicon transistor (RCA)
- T1—Transistor ignition coil, 1:250T, Mallory F12T
- S1—dpdt 15-amp 125-volt toggle switch, Arrow-Hart 82609
- MISC—Barrier terminal block, Cinch Jones 6-142. Mini-Box 2½ x 2½ x 5", Bud CU-3004A. transistor mounting kit, Motorola MK-15. (For TO-3 power transistor, 1 req.)

system to the firewall. Connect a wire from TB5 to the negative terminal of transistor coil T1 and the positive terminal to frame (no other wires to terminals).

- Place S1 in position 1 (transistor ignition mode).

- Start and run engine with normal ignition system until the battery is fully charged.

- With the engine running, connect a jumper wire in series with an ammeter to TB2 and the negative terminal of the battery. (Set resistor R1 to 1 ohm.)

- Connect TB3 to the positive terminal of the battery or auto frame, and adjust ballast resistor R1 for a current of 12 amps. The value of R1 should now be between 0.25 and 0.5 ohm.

- Stop the engine and remove the jumpers, meter, etc., and connect wires to all terminals as shown in Fig. 2. (Do not remove the distributor capacitor.)

- Place the center high-voltage lead from the distributor to the center hole of the transistor coil. Switch S1 to position 1. **R-E**

R-E PUZZLER

by EDMUND A. BRAUN

Try this "only-across-word" puzzle based on electronic terminology. Each word is connected to the one above and below by a single letter. It should be fairly easy to get a perfect score except perhaps for someone who thinks "Heaviside layer" is the problem of the obese, or that "microhms" are similar to bacteria! Got a pencil? Ready? GO!

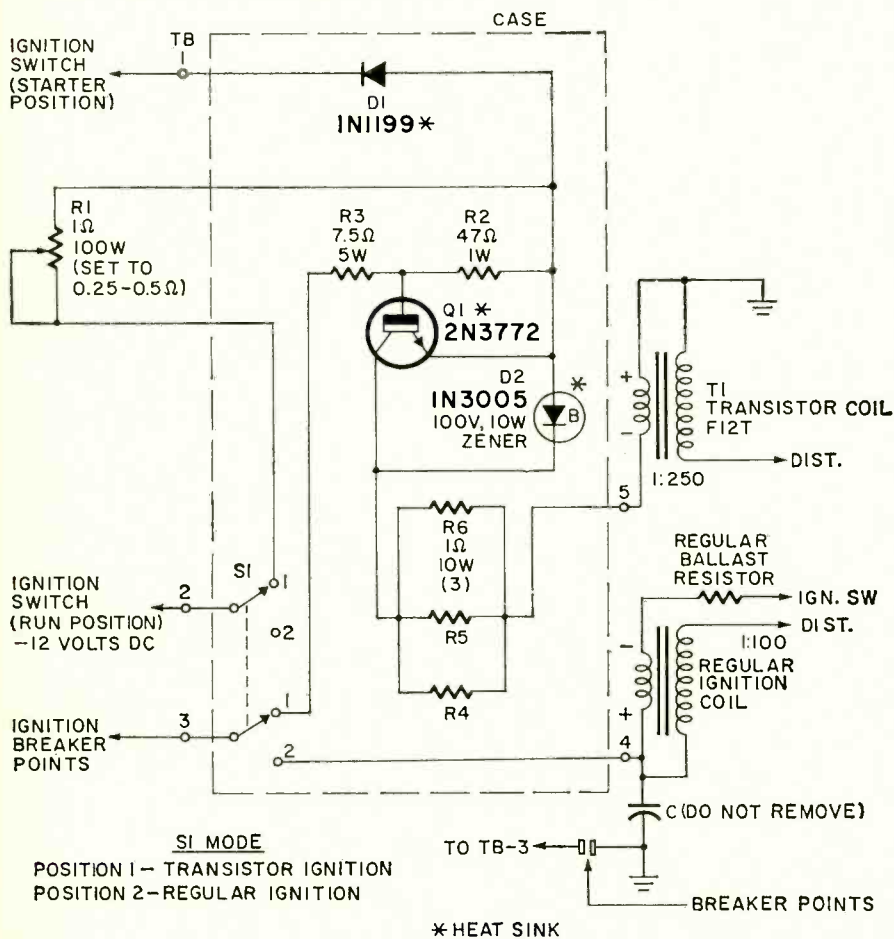
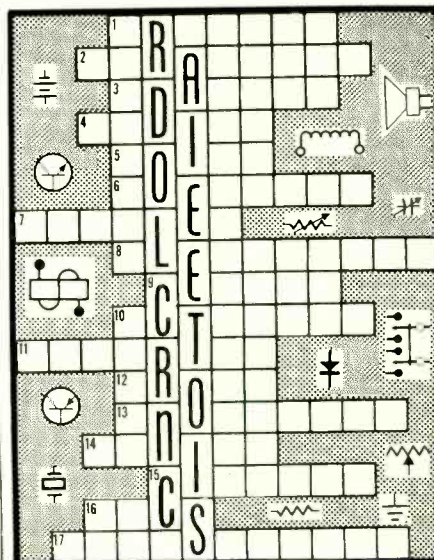

Fig. 2—Here's a circuit for an ignition system for a positive-ground car. This covers many European makes and some older U.S. models. Note that in this version, circuit ground floats. If your car has a positive ground, the positive battery terminal will be connected to the frame of the car. A glance under the hood is all you need.

- 1 A circuit which is etched instead of wired.
- 2 Speech disguiser.
- 3 Device to change terminal arrangement of a jack, plug, socket, etc.
- 4 Three-electrode vacuum tube invented by Dr. Lee de Forest.
- 5 In TV, wavy effect observed when scanning parallel lines.
- 6 Unit of radioactive exposure.
- 7 Excursions above and below the average peak amplitude.
- 8 In vacuum tubes, cathodes, grids and plates.
- 9 Alkaline metal used in phototube cathodes.
- 10 Relay part converting electrical energy into mechanical motion.
- 11 Device that changes ac to dc, or vice versa.
- 12 Color of resistor band denoting number 1.
- 13 Process to improve appearance or corrosion resistance of metal surfaces.
- 14 Metal alloy used for speaker magnets.
- 15 Complete path of an electric current.
- 16 Discharges of electricity from one point to another.
- 17 RF noises due to natural activity, such as thunderstorms.

Check your answers with the solution on Page 93

CURE COLOR TV GREMLINS

Circuits that feed signals to the color CRT can be headaches. Here's the answer

By **MATTHEW MANDL**
CONTRIBUTING EDITOR

THE INPUT CATHODES, GRIDS and screen grids of a color picture tube, not only combine the color (chrominance) signals with the black-and-white (luminance) signals, but control the relative intensity of each.

For good color reception, critical adjustments to get the proper balance are a must. The three-gun color CRT has three times as many input circuits as a black-and-white CRT. As a result, servicing problems are also more frequent and demanding, and a basic understanding of how the input circuits work helps speed troubleshooting and adjustments.

Typical input system

A typical input system for the larger-screen color sets is shown in Fig. 1. The luminance (Y) signals are applied to the cathodes. Generally, there are only blue and green drive controls. They are set to balance out with the fixed red-level drive. On some later receivers a red drive control has been added for more precise adjustments (RCA's CTC-31 chassis is an example).

A service switch permits gray-scale adjustments. It kills the vertical sweep (either by grounding some element in the vertical output section or opening a circuit), and removes the video signal input.

Color signals from the output amplifiers are applied to the individual control grids, as shown in Fig. 1. Each screen grid has an individual control for varying voltage and controlling beam acceleration. Voltage

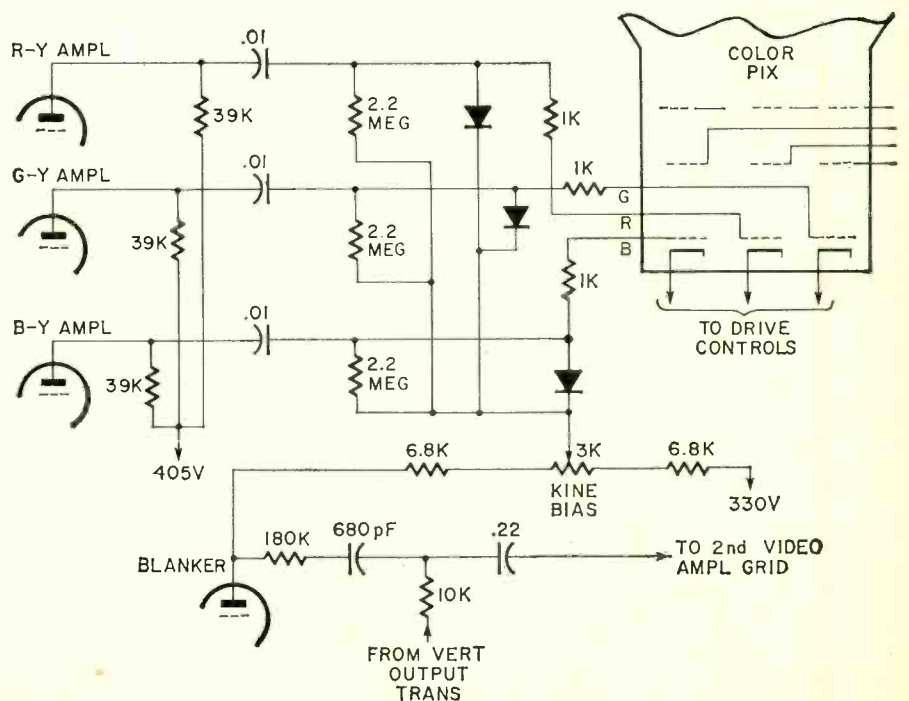
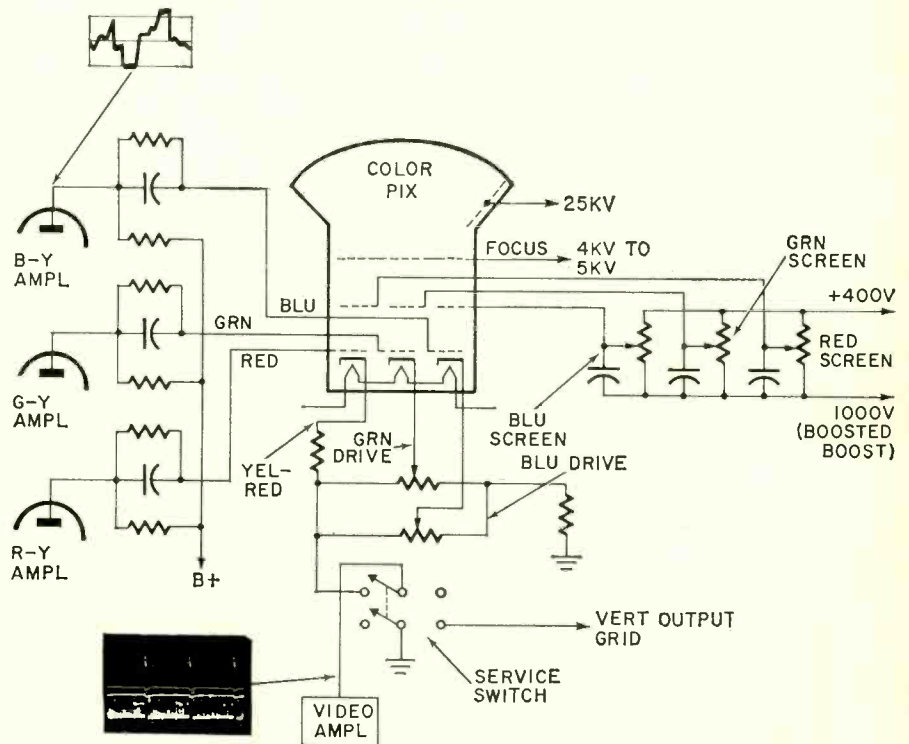

Fig. 1—(Top right) Typical input system for larger-screen color sets. The blue and green drive controls are set to balance out with the fixed red-level.

Fig. 2—(Bottom right) Bias control system is in the blanker anode circuit of this set and affects the amount of voltage applied to the color CRT grids.

may range from 400 to a 1000 (obtained from the boosted boost-voltage circuit).

A color-CRT bias control system is usually incorporated in the color amplifiers, output to the control grids. In some instances a three-position switch sets three brightness levels. On other occasions the bias control may be a potentiometer, as shown in Fig. 2. Here, the bias control is in the blanker anode circuit and affects the amount of voltage applied to the color CRT grids. Since the color amplifier anodes feed the control grids, a voltage change will affect bias and hence brightness. The blanker prevents the 3.58-MHz burst from getting to the picture tube.

Trouble symptoms

Improper colors are what you see if one of the color amplifier tubes goes bad. This also prevents black-and-white reception, since white are also dependent on a mixture of the three color signals. A scope check at the anodes of the color amplifier tubes helps localize the circuit not producing an output signal. The color signals are distinguished by positive and negative pulse-type combinations (as shown in Fig. 1), in contrast to the standard composite video signal present at the output of video amplifiers.

Also make sure the control settings haven't been tampered with. Many set owners try to make improvements themselves and eventually throw the controls pretty far off normal. In one such instance the owner insisted the color tube was defective because he could only get a black-and-white picture. It was difficult to convince him that if a color set produces a good black and white picture, the tube *has* to be good, because each gun must be working properly. In addition, convergence and purity must be good to prevent color contamination.

For total loss of color, check the

SPREADING TABS
CHANGES MAGNETIC
STRENGTH

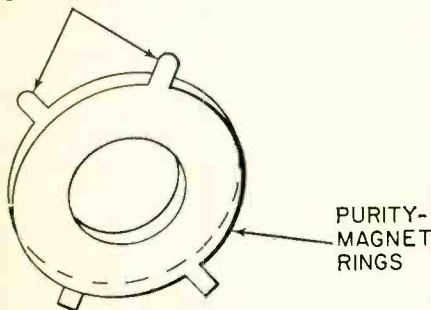

Fig. 3—Spreading purity magnet tabs apart usually increases the strength of the magnet.

settings of the color (chroma) and tint controls, as well as the color-killer threshold control. Improper antenna orientation can also kill colors completely.

Control adjustments

The screen-grid controls provide good white high-lighted areas in black-and-white reception during bright signal levels. Set the cathode drive controls (also called *background* controls) for good dark-gray tones in the darker signal levels. Tracking should be good for all brightness levels. Adjustments are called *gray-scale tracking*, or *temperature* adjustments.

Set the bias switch or control for low brightness and the screen controls to a minimum. Put the service switch into the SERVICE position to kill vertical sweep. Shunt the green and blue control grids with separate 100,000-ohm resistors and advance the red screen control until a red horizontal line is visible. (If you don't get the red line, turn up the bias control or switch for increased brightness.)

Repeat this procedure by shunting the green and red control grids with 100,000-ohm resistors and adjusting the blue screen control to produce a visible blue horizontal line. Repeat this procedure for green.

Now return the service switch to NORMAL and turn up the bias switch or control for normal brightness. Alternately adjust the drive controls during black-and-white picture reception for good reception in dark-scene areas.

If you run into trouble during gray-scale tracking, check voltages and component values in the cathode and screen-grid circuits. With the re-

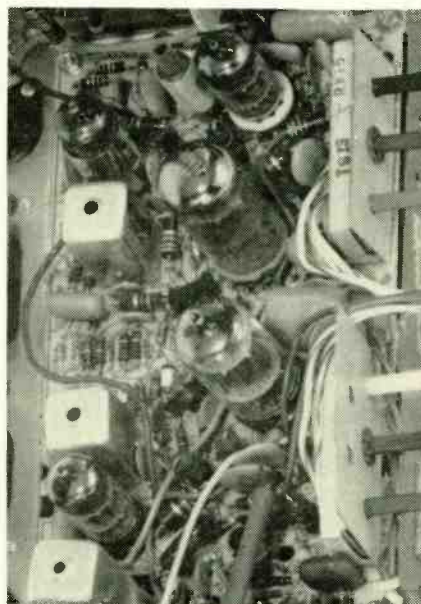

Closeup of color circuitry that feeds the color CRT in Sylvania color TV set.

ceiver off, check for smooth and uninterrupted resistance changes in each pot.

Because poor results are also caused by improper purity adjustments, check them as a matter of routine when servicing. Purity relates to the fact that the red gun must direct the electron beam within the picture tube to the red phosphors only, the blue gun to the blue phosphors, and the green gun to the green phosphors. To do this, purity magnet rings on the picture tube neck shift the three beams into proper position.

Make initial purity adjustments with only the red gun working, because a red field on the screen of the tube is easier to judge for purity. Once you get a pure red field the blue and green are usually pure too. If not, slight readjustments of the purity magnet will do the trick.

To set up purity the green and blue picture-tube control grids are shunted to ground with 100,000-ohm resistors and the tabs of the purity magnet set together. Spreading these tabs apart usually increases the strength of the purity magnet (see Fig. 3).

Next, loosen the yoke and slide it as far toward the tube base as possible. Then rotate the purity magnet slowly and spread the tabs apart until you see a uniform red area at the tube center. Next move the yoke forward until the entire screen is a uniform red without corner shadows.

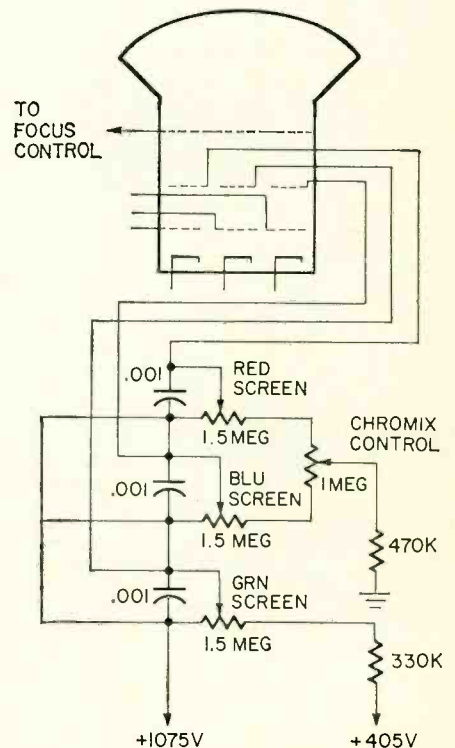

Fig. 4—Additional potentiometer in screen controls varies black-and-white picture tints.

(The purity magnets adjust for center-screen uniform field and the yoke placement affects edge purity.) Purity can now be checked for the green and blue screens by shunting the red and blue control grids with the 100,000-ohm resistors for the green field, etc.

With all three guns in operation, check for a pure white screen. The yoke may have to be repositioned slightly if there is some edge impurity.

Circuit variations

While Fig. 1 is typical for many color receivers, there are circuit variations. The Silvertone chassis 529-72130, for instance, has an additional potentiometer in the screen controls as shown in Fig. 4. It permits a slight tint variation in black-and-white pictures by unbalancing the red, blue and green levels which produce pure white. Thus, the CHROMIX control permits shading the b-w picture from slightly brownish to bluish if desired. If the screen controls are turned up too high, the CHROMIX control has little effect. So in this chassis good gray-scale tracking is particularly important.

With the circuit shown in Fig. 1 any variation of the drive controls in the cathodes affects tube bias and individual brightness of the color guns. With a more positive cathode, the

grid becomes relatively negative and reduces beam current and brightness. In the G-E HC chassis color receiver the relative bias of the grids is adjusted instead of the individual cathodes as shown in Fig. 5.

The three cathodes are common and cathode voltage is changed with a common brightness control. Once it is set for the desired level, you get color drive (brightness) balance by adjusting the blue and green brightness controls individually. With the circuit in Fig. 5, the red bias is at a set level and the blue and green controls can vary above or below the set red level for proper balance.

Gray-scale tracking and purity adjustments are similar to those described earlier. Individual bias at each grid can be read with a vtvm between grid and cathode. Voltage between cathode and ground depends on the setting of the brightness control. A variation of more than 40 volts is the normal.

If you run into trouble, check for low voltages (135 volts at the video amplifier plate feed and brightness control, and 280 volts at the other end of the control). There should be a smooth voltage change at the variable arm of the blue and green brightness controls. Erratic voltage changes as the controls are slowly advanced calls for check of resistance changes. **R-E**

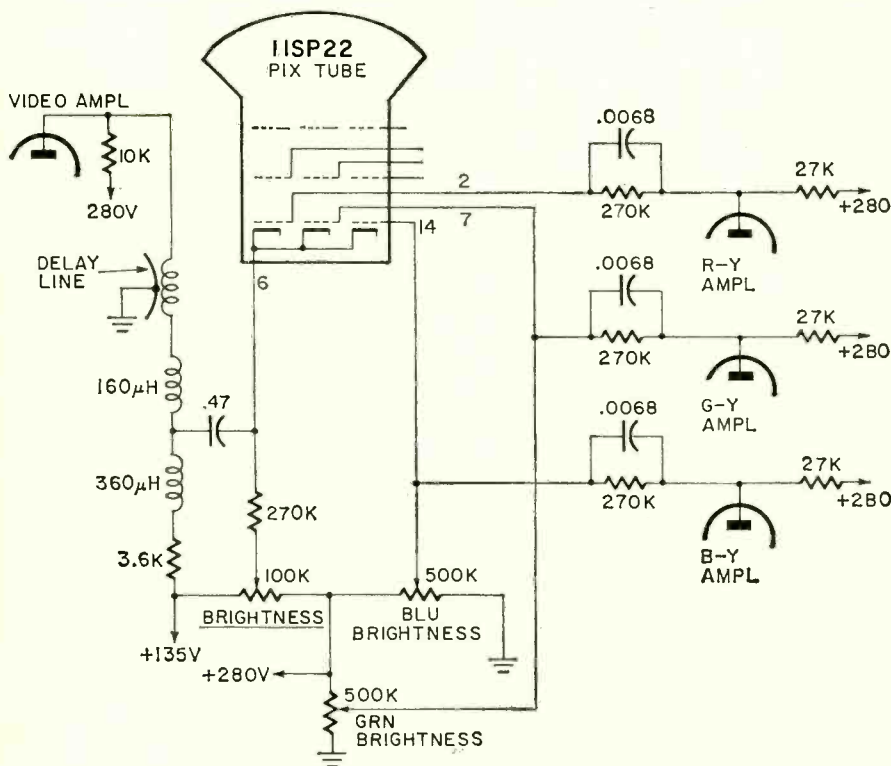

Fig. 5—In this circuit the red bias is at a set level and the blue and green controls can vary above and below the set red value. This permits easily setting up the correct color balance on the CRT.

CREDIT CARD SNOOP

ARE YOU A CREDIT-CARD SHOPPER? IF so, don't be surprised if a department store sales clerk pops your card into a mysterious box and begins pressing buttons. What's happening? Your credit is being checked in about 1/30 sec, and one of four lights hidden from your view on a card reader (foreground below) can tell the clerk how good your account is.



Credit-card authorizing system can be used with a few card readers (foreground) in small stores or with dozens of readers in giant department store chains via a central computer.

If you haven't paid your bill in months, a light may indicate the central credit office should be called for sales authorization. For most shoppers, however, a "go" light will save tedious minutes waiting for a credit search of the store's files.

National chain stores with 1 million credit cards in circulation figure some 50,000 of these cards are bad risks. This new authorizing system, developed by Digital Data Systems Corp., is being rented to retailers—large or small—to stop losses from fraud and bad debts.

Sales-counter card readers are tied to the computer-like central processor and credit-office console. To keep the size and costs of the system down, integrated circuits were used extensively. The card-reader circuit board shown here, for example, contains more than 20 IC's, and the system uses medium-scale-integration IC's developed at Texas Instruments that replace several regular IC's. **R-E**

For your car

1---2---3

Sequential Turn Signal

Reliable solid-state unit works with minimum wiring changes. Gives your car that modern look

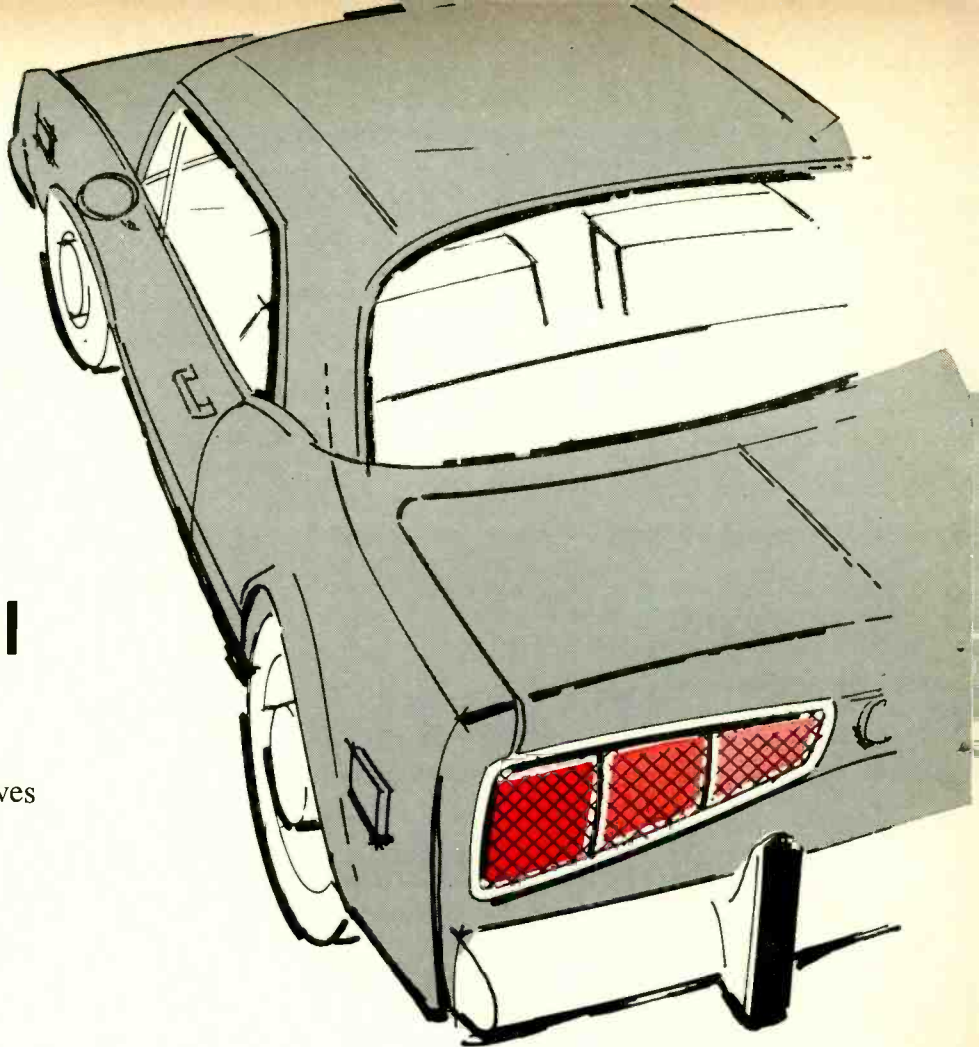

by JAY NUNLEY

THIS SOLID-STATE CIRCUIT WILL TURN ON YOUR REAR TURN-signal lamps, provided you have three on each side of your car, in a 1-2-3 sequence after the fashion of the late-model Thunderbirds and the Cougars. Sequential turn signals add a touch of style to your car and may provide a degree of added safety in that they point out the direction of the intended turn more dramatically than a simple on-off flash. If you want sequential turn signals (and have the necessary lamps on the rear of your car), this circuit will do the job reliably with an absolute minimum of modifications to your existing wiring.

The circuit was designed with the average driver in mind. That is the driver whose desire for sequential turn signals is not sufficiently strong to compel him to make major alterations to his car. He would not want to install additional wires, modify his turn-signal switch (which is buried inside the steering wheel hub), or undergo other

great difficulties in performing installation. Furthermore, he would want to be able to convert back quickly to the original system, for safety's sake, in the event the sequential system failed.

Operation

Except for the portion in the dashed-line box, Fig. 1 shows the basic idea of a car's brake/turn-signal lamp system. When the turn-signal switch is in the center position, all lamps are connected to the brakeswitch line. Step on the brake and 12 volts is applied to all lamps. When the turn-signal switch is flipped in one direction or another, the brake-switch line is removed from the signaling side and 12 volts is applied to the lamps on that side through the flasher, which interrupts the 12 volts at a more-or-less regular rate. The side which is not signaling continues to be connected to the brake-switch line. We will ignore the tail lamps, which are actually lower-wattage filaments in the same bulbs as the brake/turn-signal lamps and which remain unchanged.

At the rear of the car we have only two lines coming in for the brake/turn-signal lamps, one for the right side and one for the left. If the brake is applied, we want all lamps to go on together without the sequential effect; if the turn signal is applied, we want the sequential effect. Since 12 volts is applied in either case, we must find a way of distinguishing a brake signal from a turn signal. The 2.7K resistor shown in the dashed-line box in Fig. 1 does the trick. In effect, it applies an "attenuated" 12 volts to the lamp wires around the brake switch. This attenuated 12 volts gets through only to the side or sides selected by the turn-signal switch to receive the brake signal and thus identifies the times when the lamps are to go on all together.

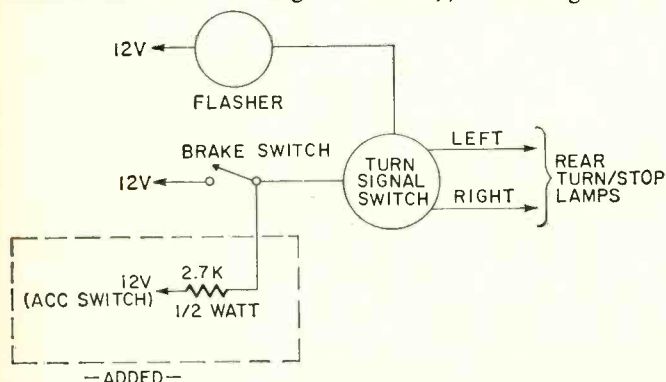
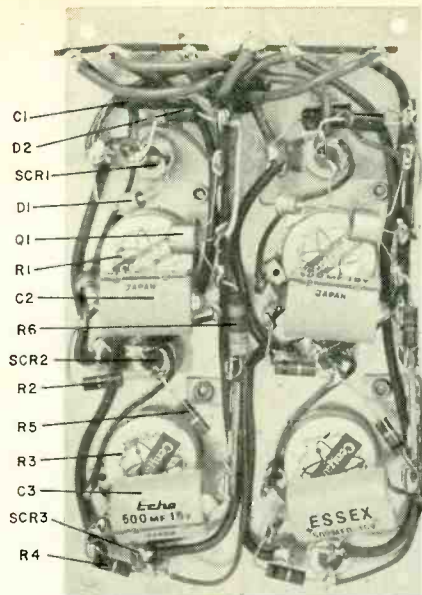

Fig. 1—Basic automobile brake/turn-signal lamp system. Flasher interrupts 12 volts at regular rate when the turn switch is on, and brake-switch line is disconnected.



The photo above shows parts layout inside the turn-signal box. The parts in the uncoded half duplicate those noted. Fig. 2—One side of the sequencing circuit, which must be duplicated for other signal side. Lamp 2 has ¼-sec delay.

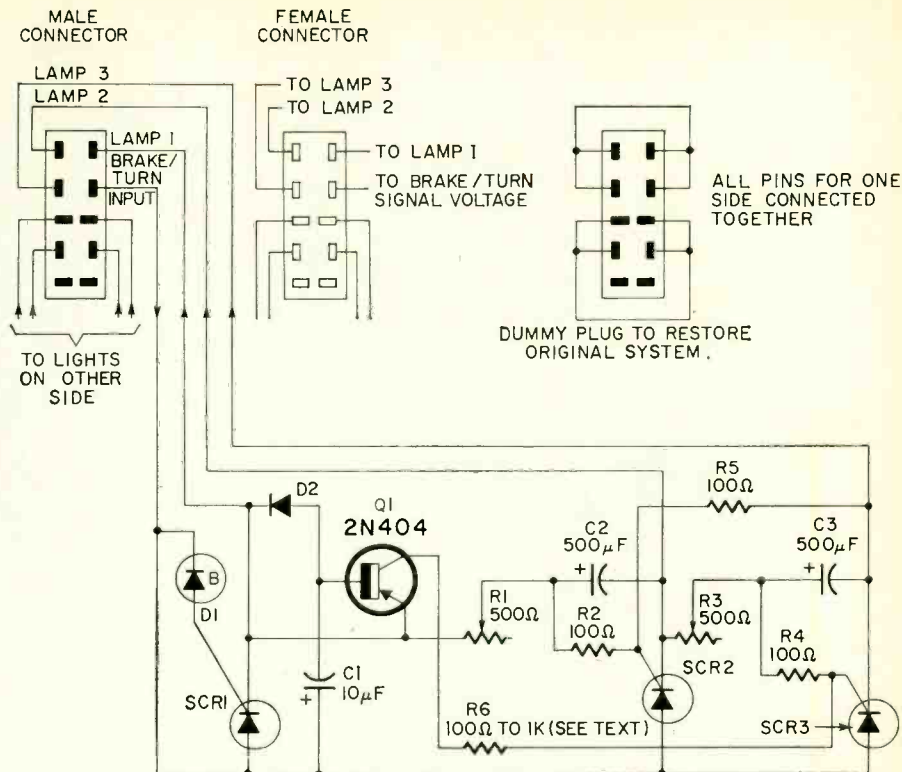

Figure 2 is the schematic diagram of the sequencing unit. Only one side is shown; two such circuits must be built for a complete sequential system. For the time being, ignore Q1, D2, C1, R5 and R6, which have to do solely with the brake mode. When the turn-signal switch is flipped to signal a turn, 12 volts is applied to the anodes of the three SCR's and to the cathode of D1. The Zener voltage of D1 is exceeded, and so current is passed to the gate of SCR1, turning it on immediately. This lights lamp 1 and applies 12 volts to C2 through R1. There is a delay while C2 charges to a voltage sufficient to trigger the gate of SCR2. Then SCR2 is turned on, lamp 2 lights, and 12 volts is applied through R3 to C3. After a delay, SCR3 is turned on and lamp 3 lights. Now, all three lamps are on, the car's flasher is properly loaded and, after a delay, opens, turning off the lamps and the SCR's. Incidentally, the SCR's *must* be turned off externally, since once triggered into conduction they remain on as long as there is a minimum holding current through them. The flasher remains open for a brief period, then closes, whereupon the sequence described above is repeated.

The turn-on delays of lamps 2 and 3 are provided by the RC time constants of R1-CE and R3-C3. The values chosen yield about ¼ second maximum. R1 and R3 are adjustable to compensate for differences in components so that an evenly spaced sequence may be obtained, and to allow the constructor to select the sequencing speed which has greatest esthetic appeal. R2 and R4 are used to give an elevated turn-on point for the gates of SCR2 and SCR3. If the delays obtained with maximum settings of R1 and R3 seem too short, which may be the case if the gates of SCR2 and SCR3 are unusually sensitive, the delay may be increased by increasing the values of R2 and R4.

Notice that the circuit does not require a ground connection. The necessary ground (negative) returns are provided through the lamp filaments which, when cold, have a resistance of less than an ohm. Placing the lamps in series with the cathodes of the SCR's has the advantage of providing pulsed operation of the SCR gates, which promotes SCR longevity. The instant the SCR's turn on, their cathodes rise to 12 volts, so the potential between

gate and cathode is zero and gate current is terminated.

The front turn-signal lamps are in no way part of this circuit. They are connected in series with the car's flasher, and go on when the flasher closes per original design. The only effect the sequential system has on the front turn-signal lamps is that their on period will be a little longer than before, since they remain on while the rear lamps go through the 1-2-3 sequence. Then the front lamps go off when the rear lamps are turned off by the flasher. The effect is very little different from the original.

As stated previously, when the brake pedal is pressed we want the rear lamps which are not engaged in signaling a turn to go on simultaneously without sequencing. To do this, the circuit obtains information from the brake/turn-signal line during the lamps-off period. When the turn-signal switch selects the brake-switch line, but the brake switch is not closed (brakes not applied), 12 volts is routed to the sequencer circuit through the added 2.7K resistor (Fig. 1). The value of this resistor is chosen so that it limits the current to a level below the holding current of the SCR's; hence the SCR's and lamps are off. The 12 volts sees a path to ground through D1, the gate and cathode of SCR1, and the filament of lamp 1. But D1 has a reverse breakdown of 10 volts, so 10 volts appears at the input of the sequencer circuit. This 10 volts charges C1 through D2 and the filament of lamp 1.

When the brake pedal is pressed, the brake switch bypasses the 2.7K resistor and applies 12 volts to the input of the sequencer. Instantly SCR1 and lamp 1 are turned on and, since it is tied to the cathode of SCR1, the emitter of Q1 becomes 12 volts positive. The negative end of C1 is blocked by D2 from discharging directly through SCR1 and so C1 discharges through the base and emitter of Q1 and SCR1. This discharge of C1 briefly turns on Q1 and the collector of Q1 becomes positive. Positive voltage from the collector of Q1 goes through R6 to the gate of SCR3, turning it and lamp 3 on. When SCR3 is on, gate voltage is routed to SCR2 through R5, turning on SCR2 and lamp 2. The delay between turn-on of lamps 1, 2 and 3 is small and all appear to light simultaneously.

During turn-signal operation, the 2.7K resistor is out

Here's the assembled unit. Lamp delays are individually adjustable with potentiometers on front. Plug connects unit into car's lighting system.

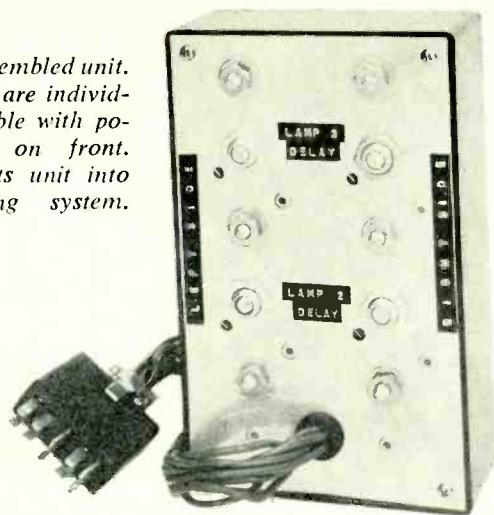

of the circuit and so C1 is not charged during the lamps-off period; hence, Q1 is not turned on and the 1-2-3 sequence takes place. In brake mode, there is a minimum off time required to charge C1 as determined by the RC time constant of the 2.7K resistor and C1. This turns out to be something in the neighborhood of 0.03 second. Therefore, if the brake pedal were released and reapplied in less than 0.03 second, C1 would not be charged, Q1 would not be turned on, and the lamps would turn on sequentially instead of simultaneously. But brake pedals, because of their weight and the inertia of the mechanism they are attached to, cannot be released and reapplied in 0.03 second.

Construction and installation

The two circuits, one for the right side and one for the left, can be built on the same or separate chassis; they are independent of each other. The SCR's are efficient and don't require expensive finned heat sinks; mounting the studs of the SCR's through the metal of the chassis with appropriate electrical insulating hardware will suffice. The studs of the SCR's are the anodes and will be at +12 volts, so must be kept from contact with any conducting parts of the car.

The SCR's are the most expensive parts in this circuit, but the cost can be justified on the basis of expected reliability. Just about any SCR's that will handle 3 amperes or more at 12 piv or more will do, and they needn't all be the same. Minimum holding is a critical parameter and it's a parameter you cannot buy on specification off the shelf. Manufacturers specify some minimum current at which the SCR will remain on, but they generally don't specify the lower current limit below which the SCR will turn off. The current through the 2.7K resistor is less than 5 milliamperes, and I find that this is below the holding current of nearly all SCR's in the 3-ampere forward-current range. But occasionally you will find an "eager" SCR, one that wants to stay on clear down to 1 milliamperes or less. If this happens, the drop across the 2.7K resistor will be large, C1 won't charge during the lamps-off period, and in brake mode the lamps will be on sequentially. One way around this is to increase the value of the 2.7K resistor, but then the charging time of C1 would be increased. Best bet is not to use an "eager" SCR in this circuit; save it for an ac application where minimum holding current is not important.

The value of R6 depends on the leakage current of Q1 and to a larger degree on the sensitivity of SCR3's gate. Start with a value of 470 ohms, which will work in many cases. However, if you find that the unit refuses to

sequence in turn-signal mode, that is, all lamps flash on and off together, increase the value of R6 in 50- or 100-ohm increments until the defect is corrected. On the other hand, if the unit sequences properly in turn-signal mode but also sequences when the brakes are applied, reduce the value of R6 until the defect is corrected.

Terminate the sequencer unit with a male connector capable of carrying about 9 amperes for the input and 3 amperes for each of the lamps. Contacts can be paralleled for added current-carrying capability. In your car, each of the rear lamps will have two wires going to it, one for the low-wattage "tail" lamp filament and one for the higher-wattage brake/turn-signal lamp filament. If you can't determine which is which, cut one and turn on the car's parking lights. If the "tail" lamp is out you've cut the wrong one and will have to splice it back together and cut the other one. Wire the lamps and the brake/turn-signal line to a female connector as shown in Fig. 2. Lamp 1 is the one nearest the center of the car. Then prepare a dummy male connector as shown in Fig. 2. If the sequencer circuit fails, disconnect the sequencer circuit connector and install the dummy connector in its place. This restores the original system. However, the SCR's should be extremely reliable in a noninductive switching application of this type, and long, trouble-free operation of the unit is to be expected.

If your car has fewer than three brake/turn-signal lamps on each side (as many cars do), and you want sequential turn signals badly enough to install additional lamps, remember that you must also change the existing flasher unit up under the dash of the car. Flashers are designed to work with a certain lamp load and if you increase the load by adding lamps, the flasher will operate so rapidly that the sequencer circuit won't get a chance to go through its 1-2-3 cycle.

If your foot is not on the brake pedal and you flip the turn-signal switch for a turn, the turn signal will flash on and off once without sequencing, after which the turn signal will sequence 1-2-3 on all subsequent flashes. The reason for this is that C1 has been charged by the 2.7K resistor in the brake-switch circuit just prior to its being switched out of the circuit by the turn-signal switch. This doesn't happen if your foot is on the brake pedal when you flip on the turn-signal switch because when SCR1 is on, C1 can't charge up. This small idiosyncrasy is scarcely noticeable, and avoiding it would involve circuit complications not worth the trouble.

If you connect the 2.7K resistor to 12 volts through the accessory side of the ignition switch as shown in Fig. 1, then if you apply the brake pedal when the ignition switch is off, the brake lights will sequence on both sides and remain on until the pedal is released. The reason for this is that when the ignition switch is off, 12 volts is removed from the 2.7K resistor and C1 won't charge. If this bothers you, it can be overcome by connecting the two ends of the 2.7K resistor to the two terminals on the brake switch, actually a simpler installation. This keeps 12 volts on the 2.7K resistor at all times, even when the ignition switch is off, but it also puts a slight drain on the battery at all times, even when the ignition switch is off. The drain is slight indeed, and it would take many weeks of this drain to discharge a fully charged battery. Because of the action of D1, the drop across the 2.7K resistor is only about 2 volts, so the drain is only about 800 microamperes. Even if D1 or C1 were shorted, the drain would be less than 5 milliamperes. Still, I have a deep-rooted aversion to walking away from my car knowing there is a closed circuit in it somewhere drawing current; so I show the connection to the accessory switch which is turned off when the car is left standing.

R-E

COVER
STORY



BUILD—R—E EXCLUSIVE

125 WATTS PER CHANNEL STEREO AMPLIFIER

By **KENNETH F. BUEGEL**

THIS ARTICLE IS THE FIRST OF THREE that will give details on how to build a complete state-of-the-art stereophonic high-fidelity system that is the ultimate in quality and performance.

The three parts are the power amplifier—it delivers 125-watts-per channel into a 4-ohm load and is burn-out proof; the stereo preamplifier—built around three IC's to reduce its complexity and improve its performance; and a most unusual FM stereo tuner—it uses variable-voltage-diode tuning and enables you to mount the front end up at the antenna for maximum sensitivity and selectivity.

This article will describe the power amplifier and its power supply. When you build the preamp (next month) it draws operating power from this amplifier. So here we go. Off to a new dimension in high-fidelity stereo sound.

In an earlier era of high fidelity sound, all speakers were highly efficient devices for transforming electrical signals into audible sound, and amplifier powers seldom exceeded to 20 watts.

Keeping pace with the recording process speaker manufacturers extended the range of frequencies linearly reproduced. At first the trend was towards larger cabinet volumes to in-

crease the usable bass range. But it soon became evident that few people wanted the huge speaker cabinet volumes associated with high-fidelity sound.

Speaker manufacturers were aware of the trade-offs in making a small cabinet volume adequately reproduce the lower frequency sounds—simply reduce the efficiency of the speaker in the middle and upper ranges. This was in direct contrast to boosting the low-range efficiency by tuning a larger cabinet volume.

The advent of stereo accelerated the advance of low efficiency speakers until today relatively few new installations are the larger cabinet volumes. Of course this lowered efficiency has forced an increase in amplifier power to maintain realistic levels of room volume. Fortunately, transistor amplifiers came along to replace the tube designs.

Early designs became notorious for their sudden death if a speaker output was shorted for even an instant. Manufacturers responded with a rash of protection circuits, almost all of which depended on limiting input current to the output transistor stages. One method of protection limits driving current to the output

Examining Fig. 1, we see that increasing current flow through R4 will cause a larger voltage drop across R4. At some current flow, the base-emitter voltage of Q1 and Q2 plus the forward voltage of D4 and the voltage across R4 will exceed the Zener voltage of D5. Increases in drive current only increase the Zener current.

Unfortunately, this theory is not too practical. Variations in the base-emitter voltages of Q1 and Q2 and the Zener voltage of D5 combine to allow substantially higher current flow at increasing temperatures. Most designs of this type require a thermal

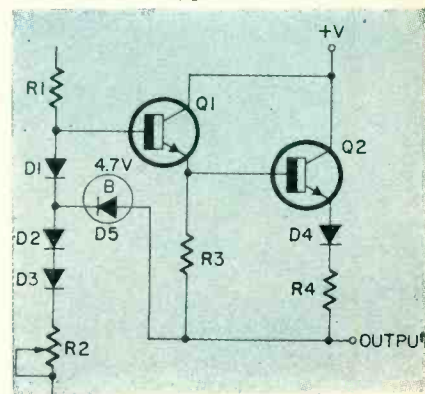

Fig. 1—Increasing current flow through R4 will cause a larger voltage drop across R4 to protect the amplifier.

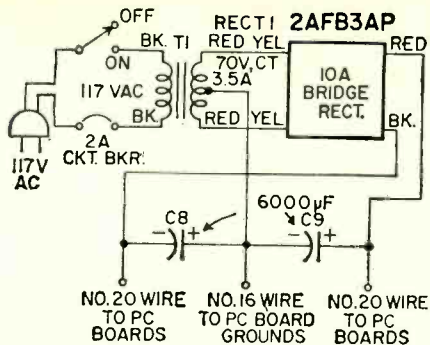

Fig. 3—Here's the power supply for the amplifier. All components used in the amplifier supply are used for both channels.

all, internal feedback eliminates the need for a control to set the dc output level of the amplifier. Looking at the schematic (Fig. 4) note that the base of Q1 is returned to ground through R3. The emitter of Q1 must be at 0.55-volt positive. Plus 50 volts is applied to the upper end of R5 and the current flow is just over 2.7 mA.

Less than 1 mA of this current flowing through R6 will bias Q3 into conduction. When Q3 conducts the resulting voltage drop across R9, R10, R11, D2 and D3 will bias the base of Q8 negative. The resulting voltage

drop across R19 in turn places Q9 in conduction. As Q9 conducts, the output terminal which is also the right end of R8, becomes negative with respect to ground. Thus Q2's base is more negative than Q1's base.

Since Q1 and Q2 emitters are connected, the current flow through Q1 decreases, thus reducing the bias developed across R6. Q3 now conducts less heavily and reduces the drive signals to Q8 and Q9. The cumulative action of this negative feedback is always in a direction which returns the output terminal to ground potential.

PARTS LIST

(two sets of parts are needed for stereo unit)

All resistors 1/2-watt 10% unless noted
 R1—volume control, log taper (10,000 ohms for transistor preamp; 100,000 ohms for tube preamp)
 R2, R13, R14, R15—1000 ohms
 R3, R8—10,000 ohms
 R4, R12, R16, R19—100 ohms
 R5—18,000 ohms
 R6—680 ohms
 R7—330 ohms
 R9, R10—3,900 ohms
 R11—approximately 47 ohms (see text)
 R17, R20—68 ohms, 5%
 R18, R21—0.33 ohm, 5 watts
 R22—22 ohms
 R23—22 ohms, 2 watts
 Capacitors
 C1—10 µF, 35 V (Mallory MTR10D35 or equiv.)

C2—100 µF, 15 V (Sprague TVA 1310 or equiv.)
 C3—100 µF, 15 V (Mallory MTA100B15 or equiv.)
 C4—250 µF, 50 V (Sprague TVA 1312)
 C5, C6—0.05 µF, 20 V disc ceramic (Centralab UK-20-503 or equiv.)
 C7—0.1 µF, 100 V paper (see text)
 C8, C9—6,000 µF, 50 V (Sprague 36D602G050 BB2A. Allied Radio catalog No. 43F 5066 \$3.52 ea.)
 Other components
 D1, D5—1N4002
 D2, D3, D4—1N3754 (RCA)
 D6, D7—1N4446 (G-E)
 D8, D9—40267 (RCA)
 L1—10 µH (Miller 4622 or equiv.)
 Q1, Q2, Q7—40406 (RCA)
 Q3—40408 (RCA)

Q4—40407 (RCA)
 Q5—40409 (RCA)
 Q6, Q9—40411 (RCA)
 Q8—40410 (RCA)
 T1—Power transformer, Pri. 117 VAC, Sec. 70V Ct @ 3.5 A (Triad R-82B or equivalent)
 RECT 1—Full-wave bridge rectifier, 300 pIV, 10 A (International Rectifier 2AFB3AP)
 Heat sinks for 40411—Wakefield NC402K (Allied Radio #60C6506)
 Heat sinks for 1N3754—Wakefield 255 (Allied Radio #60F6545)
 Etched and drilled circuit board No. DLA-1 \$3.75 each, postpaid from Transitek Co. P.O. Box 98205 Des Moines, Wash. 98016

Fig. 4—The full circuit for the amplifier is shown here. Remember this is only a single channel. Two of these circuits and

one power supply circuit (Fig. 3) must be built to form one complete amplifier. It delivers 125-watts-per-channel.

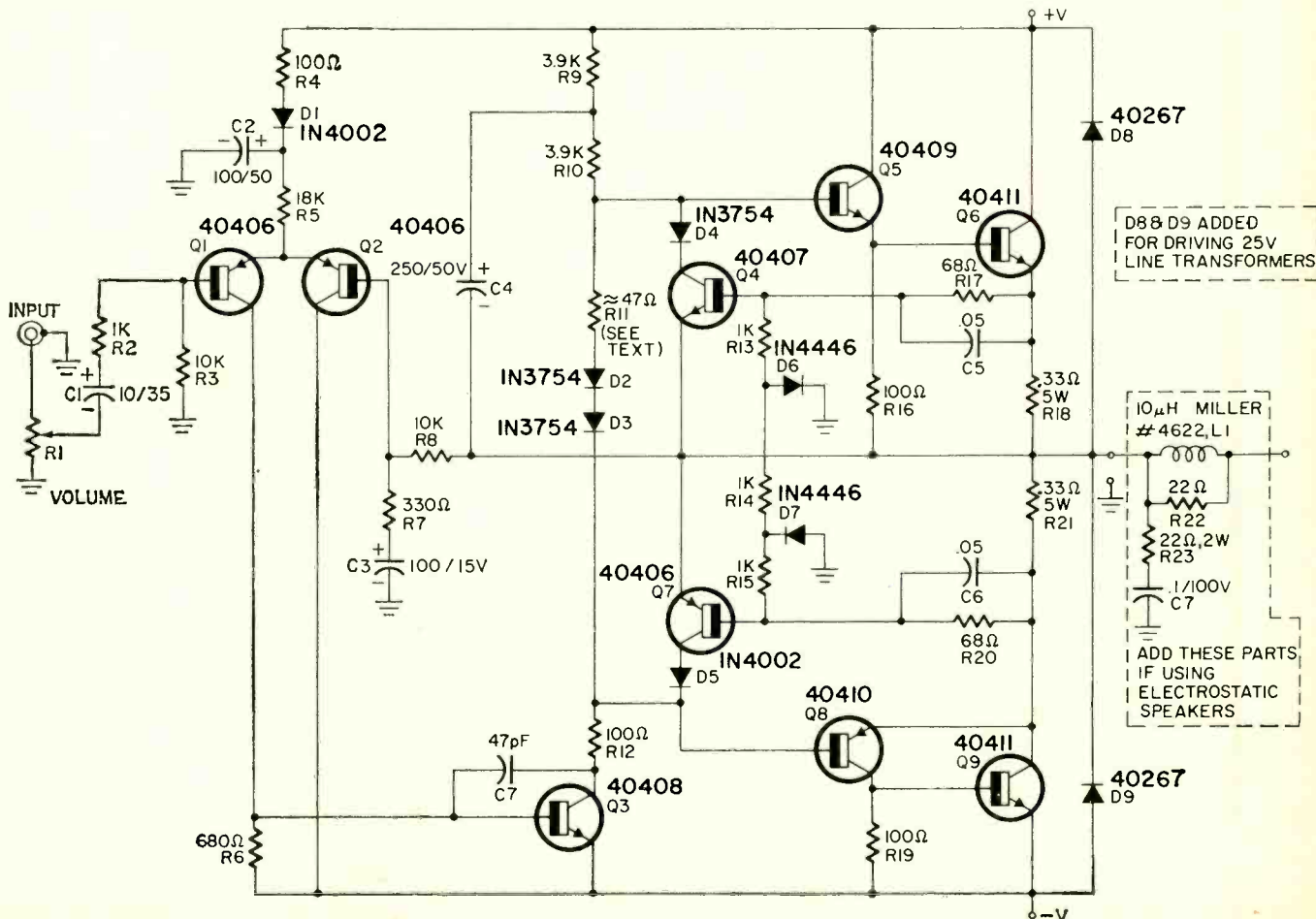

Of course, like any other feedback system, the error can never be reduced to zero. In this circuit the error is always less than 0.1 volt. With an 8-ohm speaker this results in a dc power dissipation of less than .002 watt.

The dc gain of the total amplifier is very nearly unity since C3 prevents any voltage division between R7 and R8 at very low frequencies. Capacitor C3 has a reactance of 330 ohms at 5 Hz, the point at which voltage gain is down 6 db from a 1 kHz reference value.

Resistor, R4, diode D1, and capacitor C2 prevent a very annoying "thump" when the amplifier is turned off. Let's see what would happen without these parts in the circuit. At turn off the supply voltages start to decrease due to the quiescent current drain of the output stages. As the positive voltage decreases Q1's emitter and collector currents also drop.

A reduction in Q3's bias means that the voltage drop from R9 through D3 will also be less, resulting in a more positive drive to Q5 and Q6. The increased current flow through Q6 means an even heavier load on the positive voltage remaining. This effect is regenerative and similar, in its effect, to dumping the positive charge in the 6,000- μ F capacitor directly across the load.

With D1 in the circuit, C2 stores a charge for the emitter currents of Q1 and Q2. The power supply capacitor will discharge faster than C2. No audible transients exist at either turn on or turn off.

A regulated supply for this amplifier would be quite expensive since the output impedances, at dc, would have to be less than 0.02 ohm before the performance would be equivalent to what is now exists.

There are two reasons why this low impedance is needed. First, to prevent the large currents drawn from one channel from changing the output voltage of the supply, and thus, coupling a signal into the other channel. Second, to present an extremely low source of ripple current. The same effects are present in the connection of C4.

Note that one end of C4 is connected to ground through the load; the other is connected to the junction of R9 and R10. Any ripple voltage at the positive supply terminal is attenuated by a factor of 300 before it reaches the base of either Q5 or Q8. Since the ripple voltage across the power supply capacitors is solely a function of the load current, the ripple rises as the output increases—but always remains at least 50 db below

the output voltage. The rejection from one channel to another is sufficient that one channel may be driven to full power output and the separation at 10 Hz will exceed 65 db.

Ripple on the negative supply results in a slight variation in collector to emitter voltage of Q1. Collector current, however, is not dependent on collector-emitter voltage in common-emitter amplifiers such as Q1. Consequently this ripple can not induce any voltage change across R6. Since the ripple peaks are in phase for both the positive and negative supplies their effects, small as they are, tend to cancel each other. Total hum and noise output is less than 500 mv with an 8-ohm load.

The values shown for R18 and

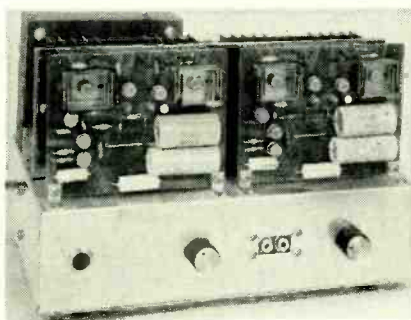

This is what the assembled amplifier less the protective cover looks like. Like it?

R21 limit the output power to 125 watts for an 4-ohm load. Operation at higher powers are possible but require forced air cooling of the heat sinks. At 125-watts output power is current limited. An output power of 100 watts is available to an 8-ohm load. Although a 16-ohm load can be supplied with 60 watts per channel the output power is now becoming voltage limited since the supply voltages must be greater than the peak to peak excursions of the output voltage.

This amplifier is stable under all conditions from short to open circuit loading on the output terminals, without signal or heavily overdriven, during normal operation, turn on or turn off situations.

Construction techniques

Using the specified parts, both amplifier channels and the power supply neatly fit onto an 8 x 10 x 2½-inch chassis. A soft aluminum chassis is not only easier to work with, but also will not transfer magnetic fields from the transformer into sensitive input circuits.

The first construction step is mounting components to the printed circuit boards. A half size layout of the board is included (Fig. 2) for the convenience of constructors who may

wish to make their own boards. Be sure to mount R4, D1, and R5 first since C4 and C2 obstruct the board entry. Use a small soldering iron and rosin core solder. If you should accidentally fill a hole with solder, heat the area while inserting a toothpick through the hole. Insert each component, bend the leads outwards slightly to hold it in place, then clip the lead about 1/16-inch above the copper. Solder the leads for a few components at a time. Keep your iron tip wiped clean. After each board is completed attach small angle brackets to the two corners. These brackets should not touch the copper foil; a separate No. 16 wire returns the circuit board to the power supply ground.

Remove the transformer shells and attach ½" aluminum angles to provide mounting feet.

Mount each 40411 transistor to a heat sink. Insulate the heat sinks from ground. This technique substantially improves heat flow out of the transistor and also reduces collector capacitance to ground. On two of the heat sinks a small bracket is used to mount D2 and D3. These diodes provide thermal compensation for the output transistors and their cases should make good thermal contact to the heat sink.

Mount all heat sinks to a 1/16-inch aluminum plate about 4 x 9.75 inches. Fasten this plate to the chassis with angle brackets placed at each end. After all assemblies are ready to mount, position them carefully. In particular, be especially careful of parts placement on the back of the chassis. The locations of the power supply capacitors should be examined carefully to avoid any interference with the output terminals.

An adequate vertical flow of air must be provided for the heat sinks. A large 2 x 8-inch slot is "nibbled" out beneath the heat sink mounting plate. If a bottom plate is used, provide a number of large holes to complete the air flow path. Use ⅝-inch high mounting feet on the chassis.

Test before using

After completing assembly, a few simple tests are in order. Temporarily connect a 100 Ω pot set to minimum resistance in place of R11. Connect a 50-watt light bulb in series with the ac line cord. Leave the output terminals unloaded and set the input level controls to their minimums. Apply power to the unit. Measure the voltage across each supply capacitor (C1 and C2). This reading should be nearly 48 volts and a dc voltmeter connected across each output should read less

(continued on page 85)



Throbbing Vibrato

by JACK JAQUES*

ADD THIS VIBRATO TO THE GUITAR amplifier described last November and you'll have given that amplifier new life. In simple terms the vibrato makes the sound pulsate—come and go at a controlled rate. This pulsating rhythm adds real life to otherwise "flat" or "dead" music. Also, with a little educated knob twisting, you can create some unusual sound effects.

While vibratos are most commonly used with guitars and accordians, the sound of many other musical instruments can be greatly improved. For example, the reed type electric chord organ can be greatly enhanced by adding a vibrato. For instruments that do not lend themselves to a special pickup, try using a standard high-impedance microphone.

If you take a look at the vibrato circuit you'll see that it consists of one transistor, one FET, 2 potentiometers, a battery power supply, input and output jacks, and the various resistors and capacitors needed to complete the circuit. The unit delivers an overall gain of 6 to 8 dB, and its high-impedance output is ample for driving most power amplifiers to full output.

In the circuit transistor Q1 is connected as a twin "T" oscillator that produces a sine-wave of approx-

imately 6 Hz. This signal is applied to the source (S) of FET Q2, where it amplitude modulates any incoming signal applied to the gate (G) of Q2 through input jack J1. The amplitude of this modulation can be varied by the DEPTH control R4, to create either a light or a deep vibrato effect. The vibrato rate (frequency) is adjusted with RATE control R11, or may be turned off with switch S1 for normal sound.

Operating the vibrato is easy. Connect any high-impedance microphone or pickup device to input jack J1. Connect output jack J2 to the high-impedance input of any amplifier system. Place the VIBRATO

switch and the POWER switch in the ON position. Adjust potentiometer R4 and R11 to approximately midrange. Then play single notes or chords on the musical instrument being used and adjust the RATE and DEPTH controls to obtain the desired effect. When operated this way, Q2's gain is effectively used, and you'll find it handy if you are using a low-power amplifier.

Complete construction details can be found in the diagrams, although parts layout is not critical. Cut the perforated board to size and carefully drill the three mounting holes. Next insert the push-in terminals where indicated. Then wire in all

The three series-connected 9-volt batteries must be secured so there is no possibility of their coming loose and damaging other components. Too, replacement should be simple and easy. Use battery clips and holders bolted to the bottom cover plate as shown.

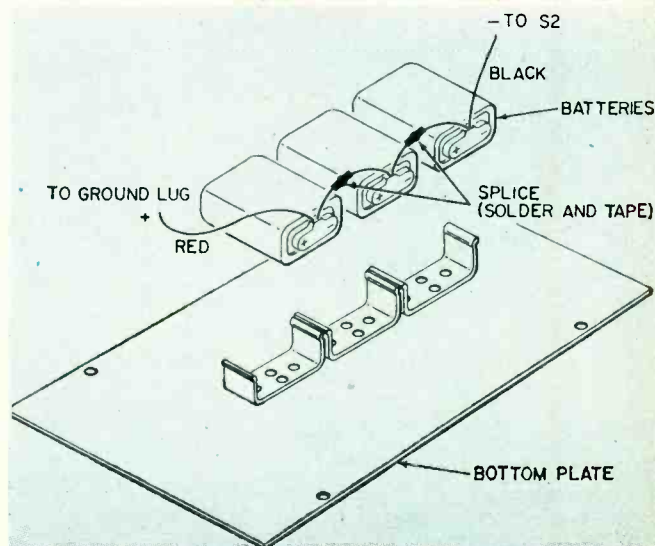

* HEP Technical Manager
Motorola Inc., Phoenix, Ariz.

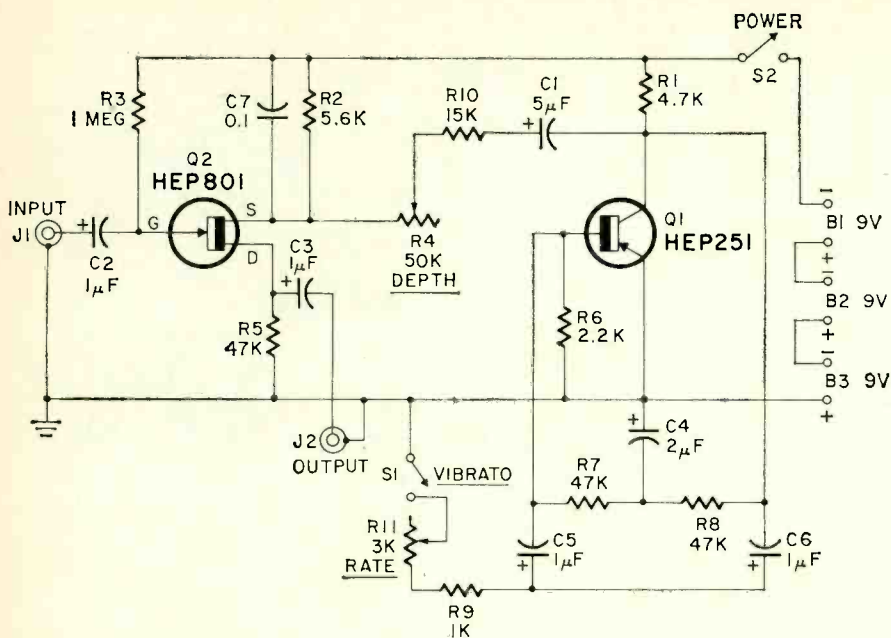

A simple, yet effective vibrato circuit. It was designed especially for use with the R-E/HEP guitar amplifier and other instruments in this series but can be incorporated in other electronic musical instruments. Vibrato effect is produced by a 6-Hz twin-T oscillator that modulates the amplitude of the signal in the source circuit of the input transistor. Input and output impedances are high.

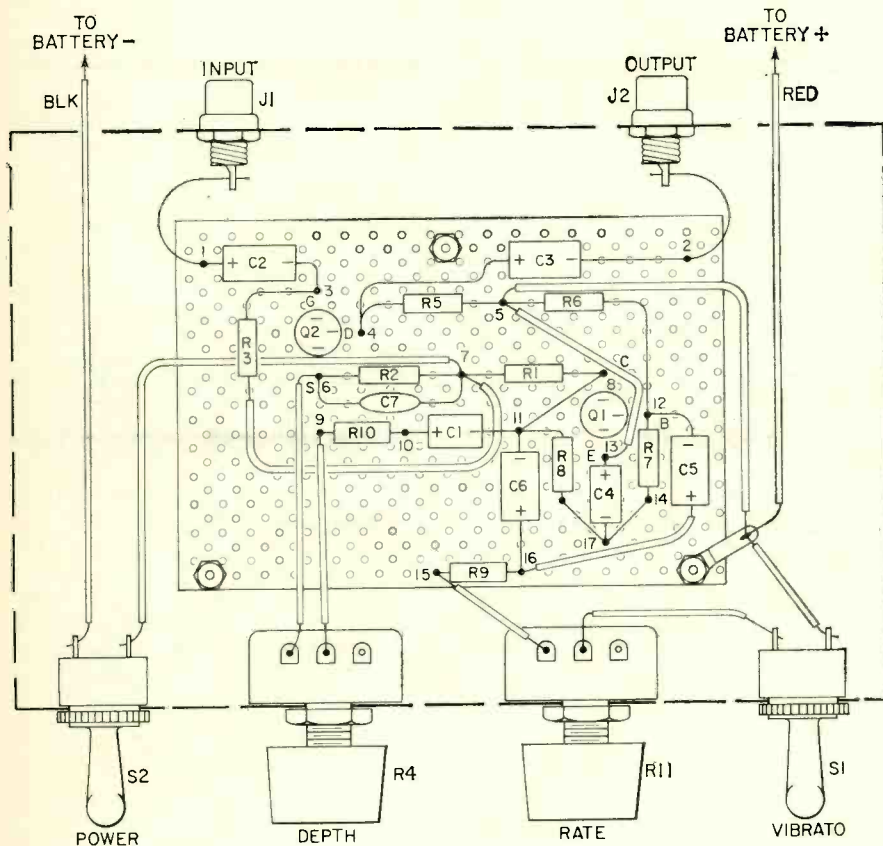

Physical layout of parts in the vibrato. Observe polarity of the electrolytics. The numbered circles represent the push-in terminals used as tie-points. Thin insulated hook-up wire is used throughout. The perforated-board chassis is suspended from the top of the case on three screws. These are visible in the head photo. Controls and switches are mounted on the front of the case; jacks are on the rear.

parts. Watch out for battery and capacitor polarity and you're home.

If you've followed along you now have a completed guitar amplifier, an inverter for outdoor operation, a mixer and a vibrato. Next time we'll present a 50-watt booster amplifier to add real power to your music system. See you then. **R-E**

PARTS LIST

B1, B2, B3—9-V mercury battery (Eveready E146X or equiv.)

Capacitors—25 volts or more

C1—5 μ F, electrolytic

C2, C3, C5, C6—1 μ F, electrolytic

C4—2 μ F, electrolytic

C7—0.1 μ F

J1, J2—phono jacks

Q1—HEP251 pnp transistor

Q2—HEP801 n-channel FET

Resistors— $\frac{1}{2}$ -watt 10% unless noted

R1—4,700 ohms

R2—5,600 ohms

R3—1 megohm

R4—50,000-ohm potentiometer (Mallory U35 or equiv.)

R5, R7, R8—47,000 ohms

R6—2,200 ohms

R9—1,000 ohms

R10—15,000 ohms

R11—3,000-ohm potentiometer (Mallory U8 or equiv.)

S1, S2—spst toggle switch

Miscellaneous parts

Chassis, 5" x 7" x 2"

Chassis cover, 5" x 7"

Perforated terminal board $2\frac{5}{8}$ " x $3\frac{3}{4}$ " (Keystone 1753 or equiv.)

Push in terminals (18) (Keystone 1499-FT or equiv.)

Battery clips (3) (Keystone 72 or equiv.)

Battery holders (3) (Keystone 79 or equiv.)

Transistor sockets (2)

Knobs (2)

Terminal lug

Machine screws, 6-32 x $\frac{3}{4}$ " (3) (for terminal board mounting)

Machine screws, 4-40 x $\frac{3}{16}$ " (6) (for battery holder mounting)

Nuts, 6-32 (9)

Nuts, 4-40 (6)

Rubber feet (4)

OVER THE YEARS THIS MAGAZINE HAS MADE MANY PREDICTIONS about the marvelous electronic devices of the future. A lot of them have already come true. One thing has been rarely mentioned, though. Who's going to fix them? They *will* be built, and they will work, but not indefinitely. Materials being what they are, and fabrication processes what they are, *some* devices are going to fail.

Our ecology is already highly automated, not only in industry but in our homes. As machine complexity increases, so do the numbers of the men who keep them running; the service technicians. While it *might* be technically possible to build the eternal machine, using to the fullest the principles of redundant circuitry and massive overrating of parts, there would still come a time when even these were exhausted and the machine would stop. Simple economics would make this approach a bit impractical as well. A home TV set would be a 30-foot cube, even with miniaturization. And the *price*?

Any extrapolation into the future must be based on the past. In the early 1930's, a radio was made with all parts "plug-in". It was widely advertised as "ending the

SERVICE 2000 A.D.

By JACK DARR
SERVICE EDITOR

need for expensive radio servicemen!" But it made practically no impression, and vanished inside a year. We can make a close guess about the design of the future TV receiver. Very thin, of the "picture-on-the-wall" type; miniaturized, with sections made in separate modules: tuner, i.f., sweeps, power supplies, etc. When trouble happens, any module can be replaced. But a skilled technician will still be needed to find out *which* module to replace! If the modules are plugged in or wired in, there will still be another chance for trouble. Don't tell me that even in 2,000 AD there will be plugs that *always* make perfect contact, and that the intermittent solder joints will have disappeared forever! I won't believe it!

Another oft-mentioned possibility is the "throwaway" unit, so cheap that it will be possible to discard it instead of repairing it. We've got the beginnings of this today, in the \$3.95 transistor radio needing a \$10 repair job.

Miniaturization will be no problem; this too is with us now. As sets get smaller, so will the tools. Today's technician repairs tiny sets under a magnifying glass. Future technicians may use binocular microscopes and micro-manipulators just as casually.

How about the test equipment of the future? Will it be a large machine, something like the cartoons of today's computers, which—hooked to the defective set—flashes a few lights and says in a bored, metallic voice, "C97 has 12,563 ohms leakage, R176 has changed value and Q97 has a base-emitter short. Replace! *CLICK!*" Probably not. That is, not unless *all* future TV sets are *exactly alike!* We have just such automated test units in use today, but they are in factories, testing one model of one make only. Their inherent inflexibility makes them impractical for general service work.

Future test equipment will look different; be smaller, more accurate, and be more stable, perhaps, but it must still measure the same basic quantities! Volts, ohms, amperes, frequencies, these won't change. The highly specialized robot testers will see greater use in the automated factories, of course, but not in the service shop. There will always be different models and makes; the principle of planned obsolescence is firmly implanted in our economy, and will be with us for a long time. Human nature isn't going to change a lot, even if the machines do. So, the test equipment of 2000 AD will still have to have enough flexibility to deal with TV sets of all sizes and shapes and makes, just as it does today, and that means measuring the basic quantities: volts and ohms and the like.

So spare me the gloomy predictions of the disappearance of the independent electronics technician, please. Increased automation of everyday devices will create an immense demand for the services of men trained in the basic principles of electronics; this is happening today. If I may do a bit of personal predicting and extrapolation, I can see this need growing by leaps and bounds. Electronics is a major factor in life today; it will be even more important in 2000 AD when there will be automatic controls on everything from the vacuum cleaner to the airliner, and all of these will be electronic!

Cities will spread, even as they're doing now. Even with fast transportation, it will take a housewife a long time to take a defective unit back to the company for repair, or an equally long time for a repairman to cross the city to fix it. So, the "neighborhood technician," simply because he's in the neighborhood, will always find enough work to keep him in business. With more and increasingly important household equipment automated, the availability of service technicians will be even more vital in the future. Any breakdown of household appliances is an emergency to the householder, and she'll still want help, and fast.

I can see one major change: the electronics repair business won't be concentrated exclusively on home-entertainment products, but cover all the electronic controls and devices in the home of the future. This is already apparent, as more and more men use their basic knowledge of electronics to work with equipment other than radio and TV. After all, the average electronic control is absurdly simple—an SCR, or a few tubes, a relay, etc.—compared to the complexity of a TV receiver. The repair business will divide up into *mechanical* and *electronic*; this is showing up today. An ordinary electronics technician can't install a set of piston rings in his car, but neither can the average mechanic repair a transistor ignition system. He simply hasn't the basic knowledge of electronics he'd need to repair it.

As to the robot testers, no machine can duplicate the *diagnostic* ability of the human brain. In 2,000 AD, as now, diagnosis will be the most important part of the process. No machine can take a set of scattered, apparently unrelated facts and reach a valid conclusion from them; a human brain can, and does, thinking nothing of it. (This is an unfortunate simile, for this is exactly what the brain does that the machine can't—*think!* Intuitive thinking is the tool we use—the machine can use logic of a sort, but it cannot think!)

The repairman will always be with us, and of far greater importance to the economy than today. Even now, if all repair activity stopped, everything would come to a grinding halt inside a week! What would it be like if present automation were increased by a factor of 1,000, as it undoubtedly will be? Try to imagine the number of skilled technicians needed to keep all these things in working order!

R-E

ADVANCES IN AUTOMOTIVE ELECTRONICS

Computerized cars are here. Learn how the newest devices work

by FRED W. HOLDER*

IN THE "EARLY DAYS" OF AUTOMOTIVE ELECTRONICS, several gadgets such as transistorized ignition and tachometers were developed by electronic buffs and small firms. The auto makers were reluctant to become involved with these gadgets because they had time-tested mechanical systems in production. A change to an electronic counterpart was not economically feasible.

Today, readily available, low-cost, solid-state components and space-saving integrated circuits have reversed this trend. The auto industry is now developing sophisticated, computer-controlled systems such as Volkswagen's electronic fuel-injection system and Ford's electronic speed control and anti-skid systems.

In addition, solid-state electronics is helping to improve such minor items as the electric fuel pump. Let's take a look at some of these new electronic innovations to see how they work.

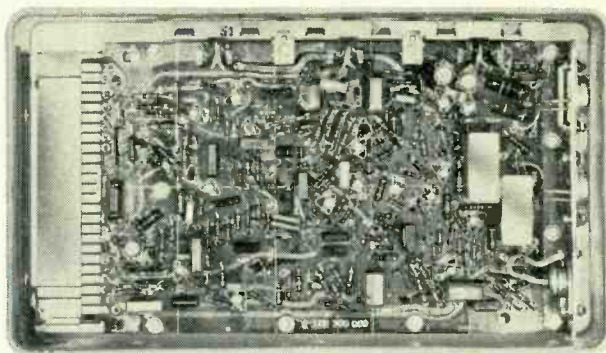

■ ELECTRONIC FUEL INJECTION

Volkswagen's electronic fuel-injection system, furnished as standard equipment on all 1968 fast- and square-back models, was developed through the joint efforts of Volkswagen and Robert Bosch GmbH of Germany. The prime purpose of the system is to increase engine efficiency enough to meet the exhaust emission requirements of the United States. The result is improved performance with little increase in cost.

The heart of this new system is an electronic control unit (or computer) that constantly monitors engine requirements and environmental conditions. It uses the information gathered to determine the correct amount of fuel needed by the engine at any given instant. Figure 1 is a simplified diagram of the Volkswagen system.

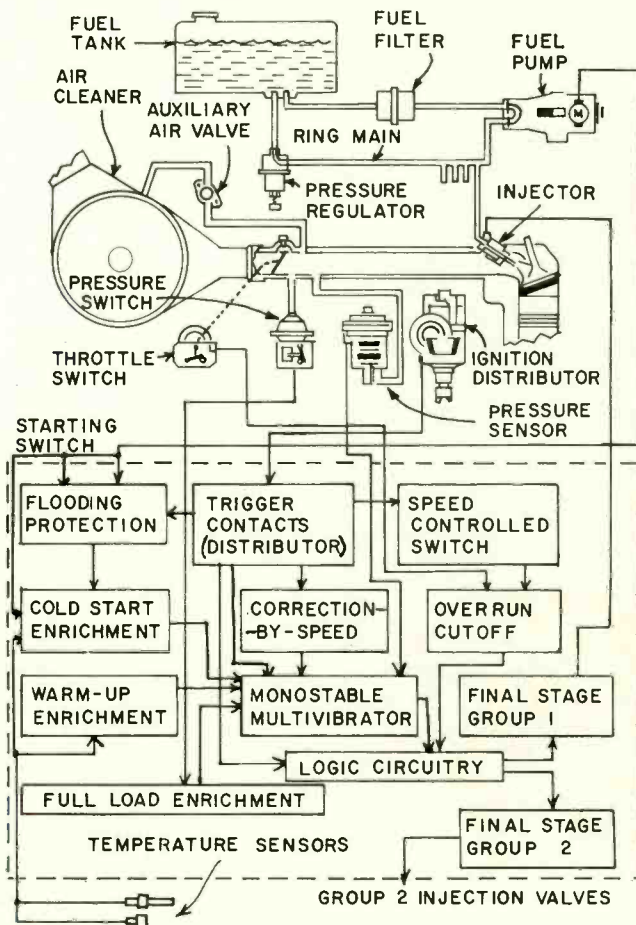

Fig. 1—In VW's electronic fuel injection system, electromagnetic injector valves are held open 8-12 msec by logic-controlled pulses generated in control unit (dotted lines).

*Supervisor, technical writing, Bendix Field Engineering Corp.

Fuel is drawn from the tank through a filter by an electric fuel pump and forced into the ring main for distribution to all injector valves. A pressure regulator maintains a constant 28 psi in the ring main by allowing surplus fuel to flow through the regulator and back to the fuel tank.

Next, the electromagnetic injector valves are opened and held open by a pulse from the control unit. This pulse varies in width from 8 to 12 msec. The duration of this pulse is governed basically by two factors: engine speed and load conditions.

Engine speed and timing information are furnished by two sets of contacts located in the lower part of the ignition distributor. Signals from these trigger

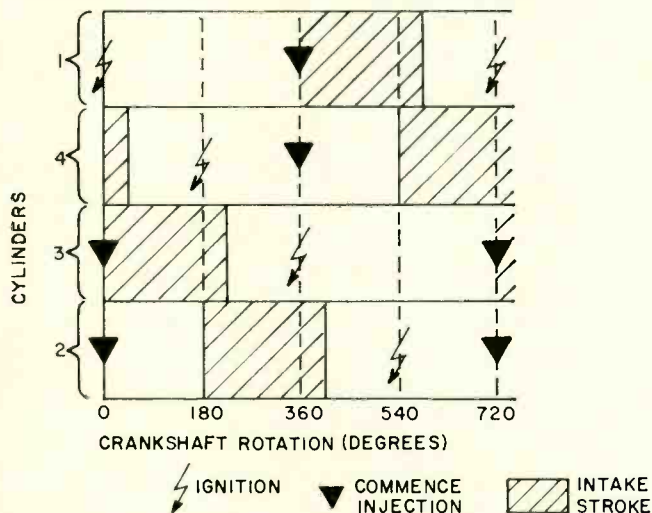

Fig. 2—Timing diagram shows relationship between injection and intake stroke of VW system. Sensors and logic circuits determine engine requirements as driving conditions change.

contacts are used in the control unit by a speed-controlled switch, the flooding-protection circuitry and a monostable multivibrator circuit.

Load condition information is furnished to the control unit in the form of a voltage signal from the pressure sensor located on the intake manifold. Other factors such as information from the cold-start circuit, the warmup enrichment circuit, the full-load enrichment circuit and the correction-by-speed circuit combine with the pressure sensor signal to establish the output pulse duration of the multivibrator.

When the control unit receives a trigger signal from one of the trigger contacts, the multivibrator switches to the unstable state for the appropriate time period determined by operating conditions. The output pulse is gated in the logic circuitry with the trigger signal and a signal from the overrun cutoff circuit.

Gating of the multivibrator pulse with the trigger signal excludes unwanted injections that could be triggered by contact bounce. The signal from the overrun cutoff circuit has no effect except when the throttle valve is closed and engine speed is above 1800 rpm.

Under these conditions, a signal is generated that inhibits the gate and cuts off fuel to the engine. As engine speed drops to 1250 rpm, the signal changes to enable the gate to switch on the fuel again so that a smooth transfer to idling operation is assured.

The logic circuitry also determines which final-stage amplifier is to receive the pulse from the multivibrator. The final-stage amplifier for group 1 drives the

injectors for cylinders 1 and 4, while that for group 2 drives the injectors for cylinders 2 and 3. Each injector group has a separate trigger contact in the distributor. Fuel is injected to both cylinders of a group at the same time (Fig. 2).

To understand the operating sequence illustrated in Fig. 2, the reader must realize that this is a gasoline injection system in which the fuel is injected ahead of the intake valve rather than directly into the cylinder.

■ AUTOMATIC SPEED CONTROL

The automatic speed-control system available as an option on the 1969 Ford and Mercury automobiles is almost entirely electronic. This system, mentioned in a November 1967 RADIO-ELECTRONICS article, was developed by the Automotive Electronics Division of Bendix Corp. In addition to the switching circuits located in the steering wheel, the system comprises three separate assemblies: (1) a variable-reluctance speed sensor, (2) a vacuum-actuated throttle actuator and (3) an amplifier, which actually is more of a computer than an amplifier.

As shown in Fig. 3, a variable-reluctance sensor is

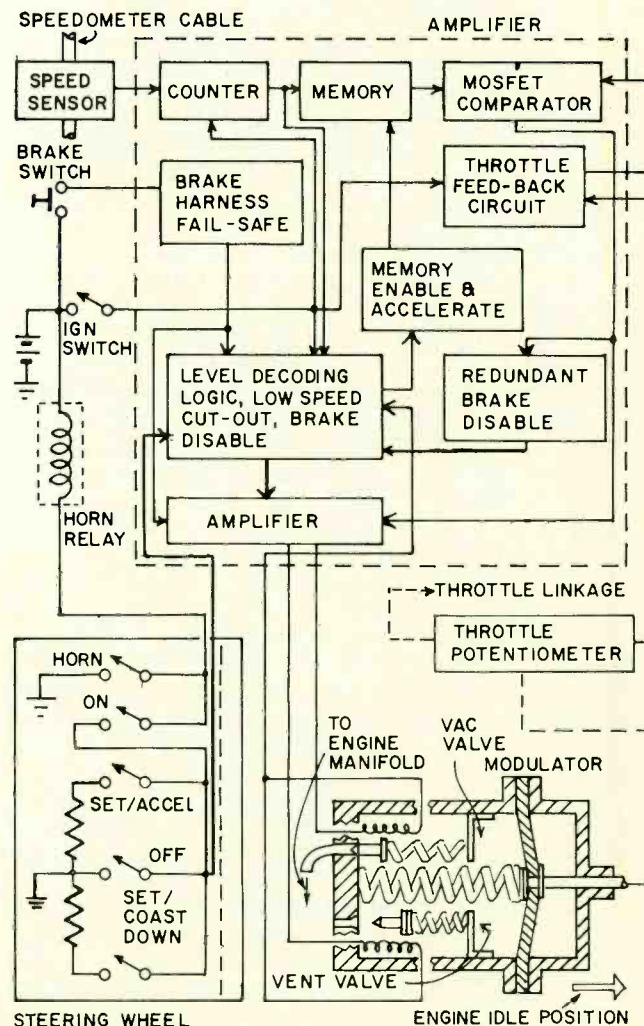

Fig. 3—Automatic speed control system—optional on 1969 Ford cars. Command speed is stored in a "memory" capacitor; a MOSFET comparator detects changes, activating throttle.

connected in series with the speedometer cable and driven at the same speed as the speedometer. Because the gear ratio between the drive wheel and the speed-

ometer cable is fixed, the sensor output frequency is proportional to vehicle speed. The sensor signal drives an energy-storage-type electronic counter that produces a dc voltage level proportional to the frequency of the input signal. This dc voltage level from the counter drives through a memory circuit into a high-impedance input of a MOSFET (metal oxide silicon field effect transistor) comparator.

The vehicle operator can impress a command speed signal on the memory circuit by momentarily depressing either the set-accelerate pushbutton or the set-coast-down pushbutton. The impressed signal represents the instantaneous speed of the vehicle.

After a command speed signal is impressed across the memory, any variations in vehicle speed will be reflected at the input to the comparator. This occurs because the memory circuit is a low-leakage capacitor connected between the counter output and the high-impedance input of the comparator. The commanded-vehicle-speed voltage level from the counter is stored in this memory capacitor. As a result, only changes in voltage from the counter are reflected to the input of the comparator.

A feedback potentiometer, mechanically connected to the throttle-linkage arm, provides a signal voltage that represents throttle position to the other input of the MOSFET comparator. The throttle feedback voltage passes through a feedback circuit that increases the magnitude of the signal when the throttle is moving. The purpose of the feedback circuit is to prevent too rapid movement of the throttle when vehicle speed is greatly below command speed, while at the same time allowing greater sensitivity of the comparator to the feedback signal as the vehicle attains command speed.

The resultant error signal from the comparator is amplified and used to control a vacuum modulator comprising solenoid valves which, in turn, control pressure on one side of the diaphragm of the vacuum modulator and actuator. These solenoid valves are electrically actuated needle valves positioned against ports in the pressure chamber of the vacuum modulator. One valve, which is normally open, allows atmospheric pressure to enter the chamber when it is de-energized. The other valve, which is normally closed, opens to allow a vacuum to be drawn in the chamber when it is energized.

The amplifier that drives these solenoid valves is designed so that an increasing signal will close the atmospheric valve. A further increase in signal strength will energize the vacuum valve and allow a vacuum to be drawn in the chamber. The diaphragm is urged forward by a spring. The reduced pressure in the chamber will allow atmospheric pressure to move the diaphragm and compress the spring. By controlling the chamber pressure, the diaphragm can be positioned at any point between the limits of its stroke. This diaphragm controls the throttle linkage.

When the brakes are applied, the brake switch closes and provides a signal through the brake harness fail-safe circuit to the logic circuit. The logic circuit is so designed that when the brake signal is received it will deactivate the speed control system. The system will not reactivate again until a command speed signal is ordered. The brake harness fail-safe circuit will shut down the system as if the brake switch were actuated should the brake harness malfunction.

As mentioned previously, if the set-accelerate button is momentarily depressed, the vehicle speed is

memorized and maintained. If, however, the button is kept depressed, the vehicle will accelerate at a constant rate (about 2 feet per second per second) regardless of vehicle speed or terrain. Releasing the button enters the new speed into memory. The same conditions exist if the set-coast-down button is kept depressed, except that the vehicle slows down.

■ ANTI-SKID BRAKES

The effect of an anti-skid braking system can be simulated by a skilled driver with a conventional braking system if he pumps the brakes rapidly during panic stops. Maximum braking effort cannot be realized under these conditions, however, because the wheels are rapidly locked and unlocked. An anti-skid system should keep the wheel brakes applied at the most effective torque without permitting the brakes to lock. It is important that the brakes do not lock because the static friction created by a tire rolling at a slower speed than the vehicle is considerably greater than the sliding friction of a skidding tire.

Maximum braking effort, therefore, may be obtained by proportioning the rotation of the wheels in relation to the forward velocity of the vehicle. According to the Bendix Brake and Steering Division, such a system can best be implemented by an electronically controlled, vacuum-actuated control mechanism.

The Auto-Linear skid-control braking system to be

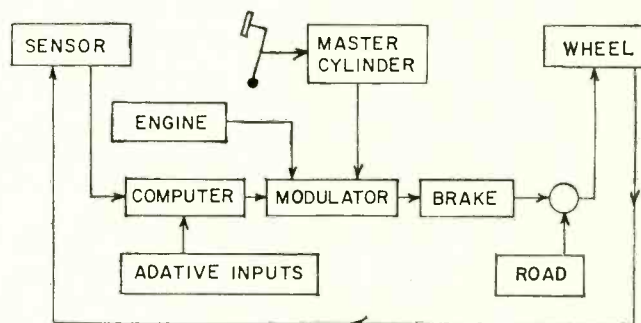

Fig. 4—A computer in this Bendix braking system determines rate of change of wheel speed, comparing it to predetermined settings. Modulator then sets pressure for best braking.

available as an optional item on the 1969 Thunderbird and Continental Mark III uses this concept. The Ford system results from a joint development effort between Ford and Kelsey-Hayes.

The most ideal system would provide individual speed sensing and pressure modulation for all four wheels. During the development of their adaptive braking system, Bendix has found that individual front wheel-rear axle control gives the best tradeoff between braking performance and system cost, while retaining steerability for evasive maneuvers, lane changes, etc.

They found, for example, the stopping distance from speeds of 40 mph on a slick surface was reduced by 35% with four-wheel control; a reduction of 15% was obtained with only rear-axle control.

On the Ford system, each end of the rear axle is equipped with a sensor that provides an electric speed signal to a 5- by 7-inch computer. The computer compares the wheel velocity signal with a predetermined program and generates control signals to operate actu-solenoid in the pressure modulator. The solenoid actu-

ates a valve to admit air to the front side of the modulator diaphragm. The resulting movement of the diaphragm allows a piston in the actuator cylinder to close a valve in the hydraulic system and isolate the brake master cylinder. Pressure in the rear brake line is reduced by this action. When the solenoid is de-energized, vacuum is restored to the front side of the diaphragm allowing the diaphragm to move forward, restoring hydraulic pressure to the rear brake line. The system can repeat this cycle about five times a second.

The Bendix adaptive braking system works somewhat similar to the Ford system just described. Fig. 4 illustrates the functional flow of information within the Bendix system. Wheel speed intelligence from the sensor is input to the computer where it is differentiated electronically to obtain a rate of change of wheel speed. The resulting signal is compared to a predetermined program and control signals are generated to control modulator valves.

These valves adjust the vacuum-powered modulator so that the correct brake pressure for maximum braking effort is applied to the wheel cylinder. This modulator is similar to the one used in the Bendix automatic speed-control system. During operations, the master cylinder is isolated so that there is no brake pedal movement.

When the car has braked to about 5 mph, the adaptive braking system cuts out to allow the normal manual braking system to take over.

■ SOLID-STATE FUEL PUMP

The Bendix solid-state fuel pump is mechanically similar to other electrical fuel pumps in that a magnetic field created by a coil actuates the pump plunger. Coil current of these pumps is normally controlled by reed switches or some other mechanical device. As shown in Fig. 5, the power transistor in the Bendix pump serves as a solid-state switch to complete the circuit of the main coil between B+ and ground.

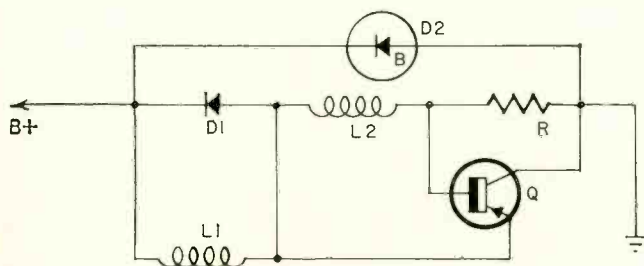

Fig. 5—Bendix solid-state fuel pump operates a plunger electromagnetically. Main-coil L1, energized through Q1, retracts plunger; L2's back emf then drives the base of Q1 to cutoff.

When electrical power is applied to the pump, the transistor acts like a short circuit, applying full voltage to the main coil, L1. The magnetic field created by the coil causes the plunger to move against the spring toward the inlet of the pump. Some of the fuel between the now-open plunger check valve and the foot valve is transferred to the outlet side of the plunger. As this sequence occurs, the voltage across L1 is dropping rapidly with increased current so that a current flows through signal coil L2.

When the plunger has reached maximum retraction, the change in voltage across L1 is no longer sufficient to maintain the field of L2. The resulting

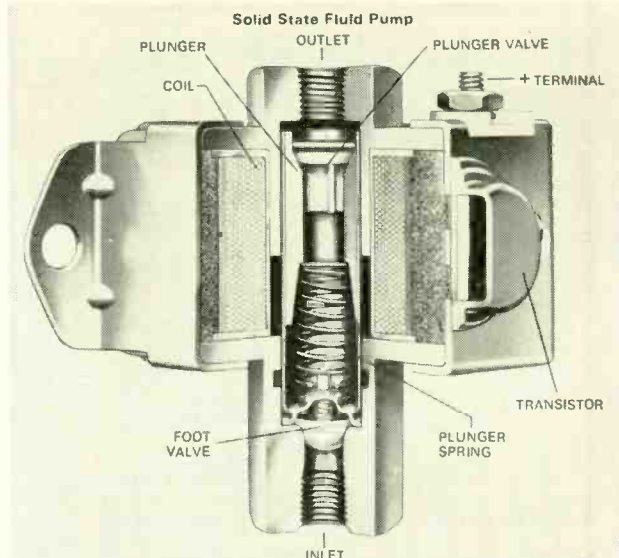

Fig. 6—Cutaway of Bendix fuel pump shows main coil with the signal coil (L2) wound around it. Coupling between the coils activates the plunger through the power transistor.

back-emf generated within L2 drives the base of the transistor to cutoff. The transistor then turns off the coil and the spring pushes the plunger toward the outlet. The plunger valve closes. Fuel on the outlet side of the plunger is forced into the discharge line. New fuel is pushed by atmospheric pressure through the foot valve. At this point, the back-emf from L2 has been expended and the transistor is again turned on. The cycle is repeated. During the turnoff phase of L1, diode D1 shunts the back-emf generated by L1. Zener diode D2 provides overvoltage protection for the circuit.

■ IN THE FUTURE

Industry forecasts show that increasing electronic applications for automotive use will continue for many years. According to reports, several items are being tested by the automotive industry.

Another item currently under development is an IC speedometer-odometer. Several systems are under consideration. According to an article in *Electronic News* (June 19, 1967), the one that appears nearest production uses a variable-reluctance pickup with a counter. In this system, the pickup mounts on a front wheel and generates about 60 pulses per minute for each mile per hour of vehicle speed. These pulses would be applied to a monostable multivibrator to drive a millimeter calibrated in mph. A system similar to the speed sensor and counter circuit used in the Bendix speed control system might be satisfactory.

An announcement in *Electronic News* (Aug. 5, 1968) said that Ford Motor Co. research engineers are planning to evaluate two new electronic control systems: (1) automatic headway control (AHC) and (2) Minigap. A vehicle equipped with AHC transmits an invisible beam at the car ahead. Taillights of that car reflect the beam to a receiver. (It sounds like infrared radar.) A computer then adjusts brakes and throttle automatically to insure a safe following distance is maintained. Minigap, on the other hand, electronically links a string of cars together into highway caravans following a special lead car. With this system, the driver hooks up, then relaxes. Sounds like Greyhound —“Leave the driving to us.”

R-E

BUILD

\$20 SCOPE CAMERA

Simple camera modification enables you to keep permanent records of experiments

by DALE E. COY

MOST EXPERIMENTERS HAVE AN OSCILLOSCOPE, yet nothing is quite so rare as the experimenter with an oscilloscope camera to keep a permanent record of the results of his experiments. One reason for this is the cost—a commercial camera designed for scope photography will make a \$400-\$1200 dent in the wallet, and can only take

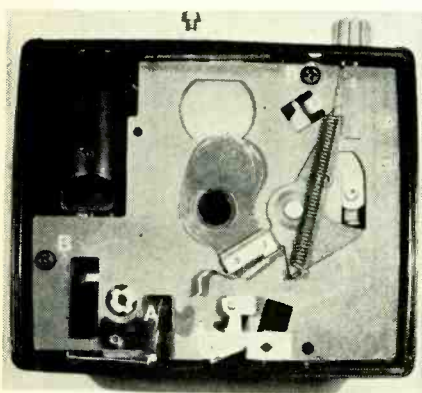

Fig. 1—Rear of the modified shutter. (A) is battery contact, (B) marks two screws holding shutter together. Lens opening is in the center of the plate.

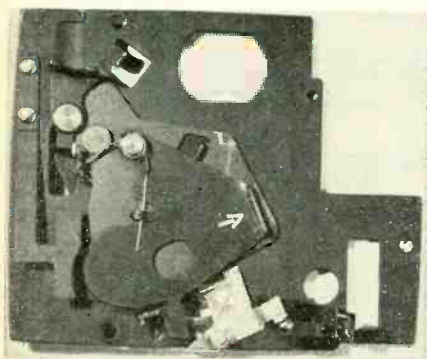

Fig. 2—Inside view of modified shutter. The tiny arrow points to bend made in shutter to provide a "bulb" position.

pictures of the scope screen. Much as we appreciate the value of this piece of equipment, few of us can justify the expense.

This article describes the construction of a simple, inexpensive scope camera which, like Superman, is often disguised as a mild-mannered camera for all the ordinary uses. You can buy a Polaroid Swinger for about \$15. or the Big Swinger for around \$20. Conversion to a scope camera will cost another \$5.

Three things are required to convert these cameras for scope photography; modifying the shutter, adding a supplementary lens; and a method for mounting the camera to the scope.

Shutter modifications

The shutter mechanism for these cameras has one fixed speed of about 1/200 second, which is much too fast for scope photography. An added "bulb" position is needed. With this type of action, the shutter will open when the shutter button is pressed, and will stay open as long as the button is held down. Since most scope photos require exposure times between 1 and 10 seconds, this is an easy shutter action to use. As an added bonus, the shutter mechanism does not have to be cocked between exposures, so multiple exposures may be made on each piece of film to place more than one trace on the picture.

To get to the shutter, first open the back of the camera and remove the battery compartment. Three small Phillips-head screws hold the lens-shutter housing to the rest of the camera. Two of them are chrome, and the other is black. Removing all of them lets the front of the camera drop off. Place the front housing on a clean cloth so the lens will not be scratched. Remove the plastic rear cover plate and the flashbulb ejector from the back of the shutter housing. You should now see something like Fig. 1,

Although Fig. 1 shows the completely modified mechanism with the shutter open, it also illustrates the next operation. Remove the two screws at B. Grasp the tab at C with needle-nose pliers and pull gently upward until the plate snaps free. Then slide the plate out from under the battery contact at A, and turn it over.

Figure 2 shows the inside of the shutter, as modified. The only change needed is to bend the end of the shutter leaf upward. Make the smallest bend you can with needle-nose pliers. Then file the bent part down so that about $\frac{1}{16}$ inch extends upward.

Modify the plastic shutter housing next. Locate the spot on top of the housing as shown in Fig. 4, and drill and tap for the stop screw to be used. This screw must be at least $\frac{3}{4}$ inch long (thread length), and no larger than No. 4. If you can find a No. 2 or 3 screw this long, it is even better. Carefully drill and tap the hole so the screw will lie flat, as shown in Fig. 3. Since the top of the housing is angled, the hole will also have to be angled. Now insert the screw, and make sure it does not bind against the

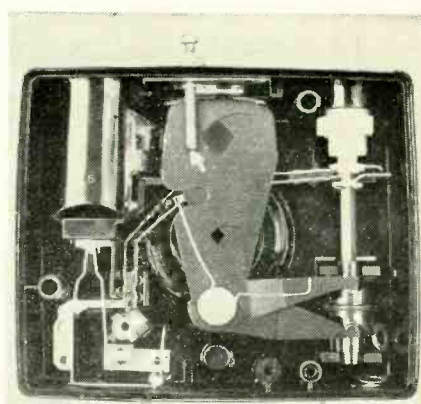
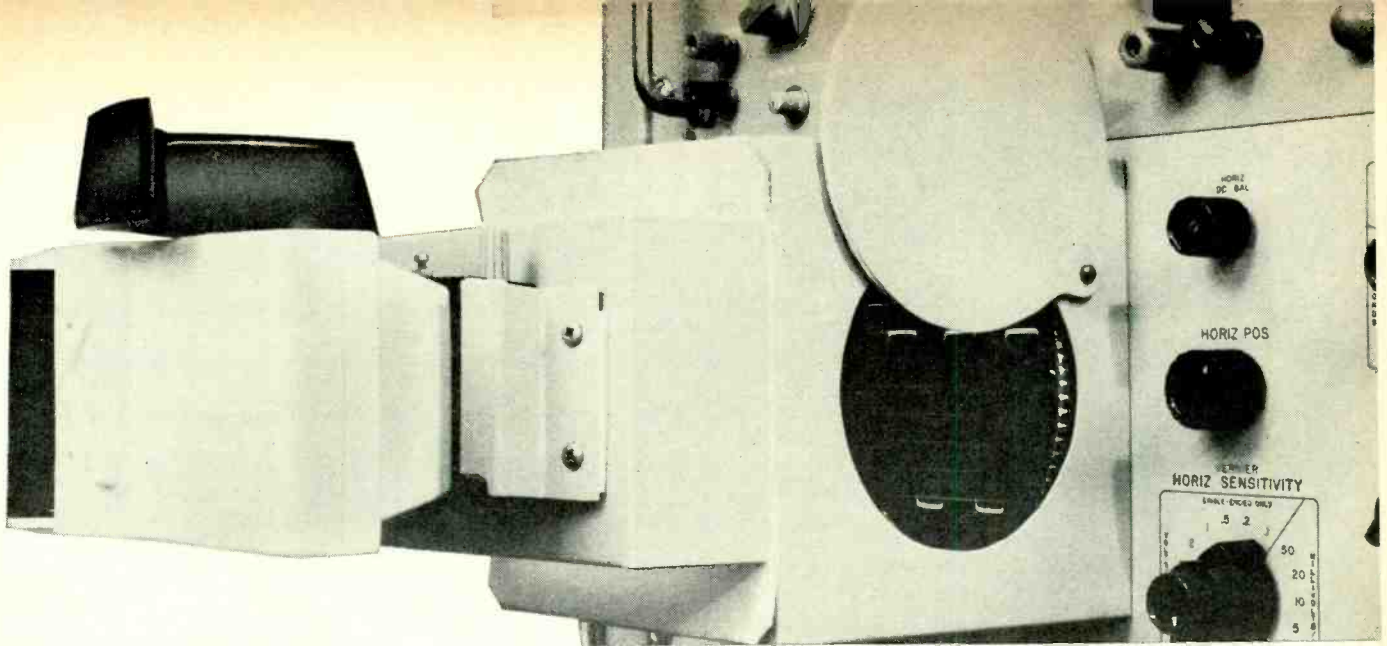

Fig. 3—Modified shutter housing. Added screw (arrow) stops the shutter leaf. The screw should lie flat and must be at least $\frac{3}{4}$ " long (thread length).



sliding blades as the red "brightness" knob is turned.

Put the pieces back together, pressing in at C (Fig. 1) to snap the plate back on. Install the screws. Press the shutter release a few times

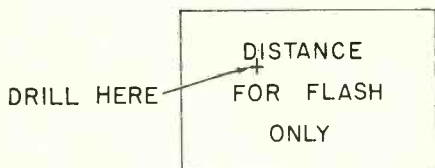

Fig. 4—Drill and tap for the stop screw between the D and I in DISTANCE.

to check for binding inside. If there is some scraping or binding, take the shutter apart again. Binding may be corrected by one of three methods: (1) filing the threads off the stop screw where it is inside the housing, (2) filing some more off the bent part of the shutter leaf, or (3) using thin shims or washers between the metal plate and plastic housing under the two screws at B in Fig. 1.

A few trial assemblies will correct any binding. When the shutter is assembled and working properly, hold the shutter release down and adjust the stop screw so that the shutter is fully open. For this operation, the red knob should be fully clockwise (away from the "darken" end).

This completes the hard part of the modification. You may want to mark the stop screw, or install a nut on the screw so that it can always be turned in to the same depth. By removing the screw and replacing it with a shorter screw (1/4 inch or less), the shutter is returned to its usual operation and the camera will work normally.

Polaroid Corp. jealously guards the lens specifications for these cameras. A rough measurement shows, however, that the Swingers have f/16

lenses with a focal length of about 100 millimeters. Most lens measurements are traditionally made in millimeters (mm). There are about 25.4 mm to the inch, so the focal length of 100 mm means that the distance from lens to film is just shy of 4 inches. A supplementary lens is needed to let us focus the camera from a distance of something less than a foot, and to fill the picture with the image of the scope's CRT. Optics is a complicated subject, but since "rough" figures are all we need, we can use a "rough" formula:

$$S = \frac{(\text{Lens Focal Length}) \times (\text{Object Height})}{\text{Film Height}}$$

In this formula, the object height is the height of the part of the CRT screen we want to photograph. The film height is the top-to-bottom mea-

surement of the film image (about 54 mm for the small Swinger and 73 mm for the Big Swinger). The value "S" is both the focal length of the supplementary lens we need, and the distance from the front of the camera to the CRT.

The object height chosen is usually not the diameter of the CRT because the pattern to be photographed usually does not go all the way to the top of the tube. Instead, a slightly smaller height is chosen.

To simplify the problem, Fig. 5 is a graph from which the correct supplementary lens may be chosen. The other necessary information is the diameter of lens needed. For the Swingers, the supplementary lens should be at least 20 mm in diameter, with the most convenient diameter for mounting about 28 to 30 mm. The best place to obtain lenses is probably Edmund Scientific Co. You can obtain

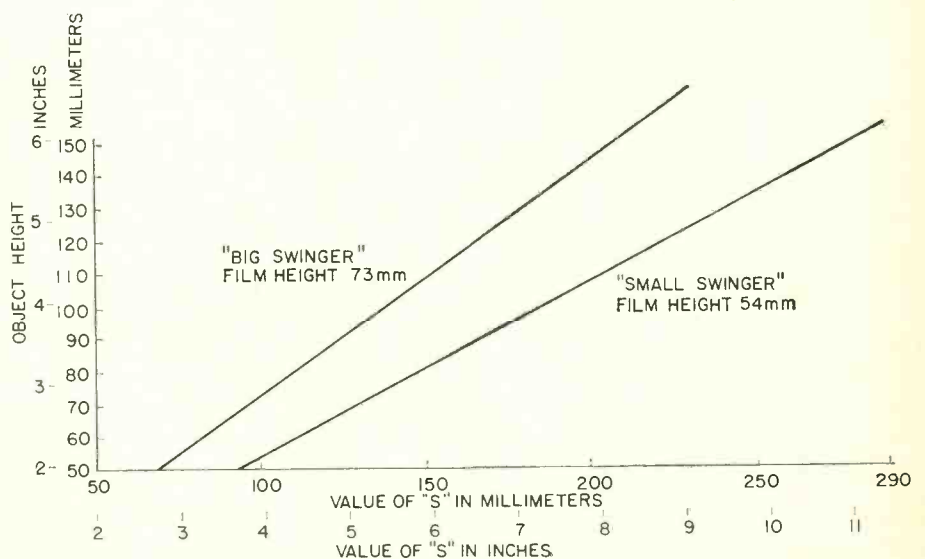

Fig. 5—Graph showing value of "S" (the focal length of the supplementary lens required and the focusing distance of the lens combination) for the 100-mm Swinger lenses. The actual focusing distance will usually be about 10% less than indicated on the graph.

their free catalog by writing to 300 Edscorp Building, Barrington, N. J. 08007. The catalog lists a wide variety of planoconvex and positive meniscus lenses with prices around \$1, and a lot



Fig. 6—Front of the modified camera. A plastic cable clamp holds supplementary lens in place. The added stop screw is on the top just to the right of center.

of other interesting gadgets. Their minimum order is \$2, so when you order your lens, also order a 2 1/4 x 3 1/4-inch piece of ground glass (No. 2143 for 50¢) for use in focusing.

Mounting the lens on the front of the camera is probably the easiest task of all. It may be simply taped to the camera lens tube or clamped on with a plastic cable clamp, as show in Fig. 6.



Fig. 7—Test of the camera with a 238-mm supplementary lens. Camera focuses at slightly less than 9 inches and covers a field approximately 4 x 5 in.

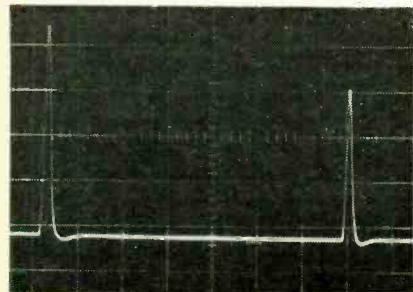

Fig. 8—Comparison of waveform photos (left) taken with a \$500 professional oscilloscope camera and (right) \$20 Swinger modified for scope photographs.

Mounting the camera

Before mounting the camera, we must find the exact distance at which the lens is in focus. With the supplementary lens in place, install a piece of ground glass (or a piece of clear plastic sandpapered on one side) in the back of the camera, where the film is located. Open the shutter, and move the camera until the image of some object (for instance, a ruler) is in focus on the ground glass. Then carefully measure the distance from the front of the camera to the object. This is the distance that the front of the camera must be mounted away from the oscilloscope. An alternate method of measurement is to take a picture of a test chart as shown in Fig. 7.

The actual distance from the front of the camera to the CRT should be slightly less than the distance measured, because the scope image is actually formed on the *inside* of the CRT. For most oscilloscopes, the image formed is actually about 1/4 inch behind the front panel.

The scope mount is made from aluminum chassis and boxes, as shown in the head photo. Since scopes vary in size and style, the final design may not match the picture shown, which is for a 5-inch Hewlett-Packard scope. The mount is held in place by the oscilloscope bezel, located inside the box. The mounting screws pass through the bezel and through the mount, and are fastened to the front panel. The box is painted flat black inside to prevent reflections. Viewing holes with sliding covers are provided in each side, so that the screen may be seen. The covers are closed before the picture is taken. The piece of felt between the two boxes shown also covers a slot which may be used for viewing. The camera is fastened to the second box by two angle brackets bent from aluminum. The lens projects through a hole cut in the box.

When the mounting is finished, check the focus by using a piece of ground glass inside the camera as outlined above. If the image of the scope trace is in focus, the camera is com-

plete. Small adjustments in focus may be made by adding felt pads between the camera and the mounting, if the distance was made too short.

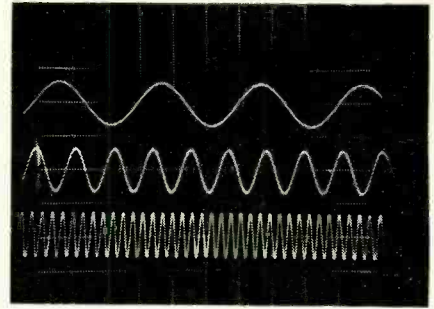

Fig. 10—Multiple exposure made by changing scope's input and trace position. This is an easy way to display waveforms when comparisons are required in the lab.

Using the camera

Using the oscilloscope camera is simple. Just set up the picture on the screen, close the viewing ports and hold the shutter open for a few seconds. Generally, exposure times will run between 1 and 10 seconds. Many things affect this exposure time, including the design of the oscilloscope, the frequency of the signal displayed and settings of the scope controls. The advantage of using Polaroid equipment is the ability to change exposure times and to see the results in just a few seconds. Because of the wide variation in setups, more specific exposure data cannot be given here. Shooting one roll of film with your equipment will make you an expert.

The scope camera may be used to make a permanent record of your experiments, to record transients and to photograph events which happen too fast or too slow for the eye to detect on the oscilloscope screen. Its versatility is limited only by your imagination. Samples of the work done by this camera are shown in Fig. 8 and 9. Quality compares favorably with equipment costing 20 to 30 times as much. For most pictures, the "darkness" control (red knob) on the camera should be set fully clockwise for the brightest picture. For extreme sharpness, you can rotate this control counterclockwise a bit, although this will cause an increase in the exposure time needed.

This inexpensive scope camera is simple to build and performs well. If you are reluctant to do the camera modification yourself, most camera repair shops will do it for a few dollars. By removing the supplementary lens and the stop screw, the camera is returned to service taking snapshots. This kind of bargain is hard to pass up. **R-E**

ABC'S OF TRANSISTORS

VDR's and Thermistors

by SYLVANIA TECHNICAL STAFF

Take a look at all the newest semiconductor devices.
There are VDR's, thermistors, FET's, VVC's and more

EVERY SO OFTEN YOU'LL HAVE TO TEST voltage dependent resistors (VDR's) and thermistors and then decide whether or not they should be replaced. First let's take a look at the VDR.

Physically, the VDR appears as in Fig. 1-a and Fig. 1-b. Don't be fooled by the appearance of the unit in Fig. 1-b. It may look like a precision resistor but it isn't. The electronic symbols for the VDR are in Fig. 1-c. VDR's are used to present a high impedance to small applied voltage and as the voltage increases the VDR's resistance decreases and allows more and more current to flow.

The VDR is used to cut pulse-peak variations by providing in a high resistance when the voltage is low, and a low resistance when the voltage

is high. In the vertical circuit of a TV set it is used to provide a low resistance to the large vertical pulse during trace time, and during retrace its increased resistance allows the retrace voltage to maintain its full amplitude for fast retrace. The VDR in the video supply provides a form of regulation and filtering action in a voltage divider network.

Automatic degaussing circuits in color sets use a VDR in conjunction with a thermistor to allow heavy current to flow through the degaussing coils. As soon as the temperature of the thermistor rises, the voltage across the VDR falls, its resistance increases, and current flow through the coils is effectively stopped. Most VDR's will carry 10 times more current when the voltage applied is increased one to two times over a specified range.

An ohmmeter reading will tell you very little about a VDR since VDR's have such wide variation in resistance. Out-of-circuit readings will be in the megohm range. If the unit has failed it will probably fail in the open mode. Often, the easiest way to verify operation is to substitute a new VDR in place of one whose operation is questionable.

Factory tests for a VDR call for a variable dc supply near the VDR voltage rating. One milliamp of current is made to flow and a voltage reading taken. When the voltage is increased until 10 milliamperes flow, the two voltages are from 1.5 to 2, as shown in Fig. 2. The rating ratio provides the change in voltage (ΔE) required to produce a change in current magnitude of 10.

Thermistors

Most thermistors used in TV chassis have a negative temperature coefficient (NTC). Their characteristics are used where less resistance is required as a circuit comes up to tem-

perature. (Fig. 3) One common application is to use a thermistor in series with tube heaters to protect them during heater warmup. They are also used in the vertical output transistor amplifier to maintain constant vertical sweep voltages over the temperature range of the set. Color TV's use a thermistor to develop a voltage while still cold to divert ac to the degaussing coil circuit.

A typical thermistor value when cold is 120 ohms and when hot about 20 ohms. Two ohmmeter measurements are needed to check a thermistor—the hot and the cold resistance readings. If these readings fall in the expected range the part is usually con-

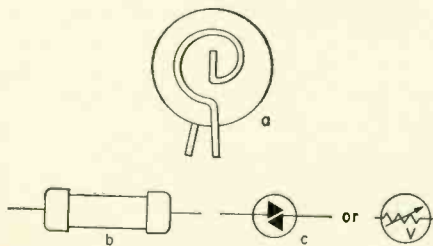

Fig. 1-a and b—Drawings of two types of VDR's used in TV and other circuits. Two electronic symbols are shown at c.

$$\text{MAX RTG.} = \frac{\Delta E @ 10 \text{ I}}{E @ \text{I}}$$

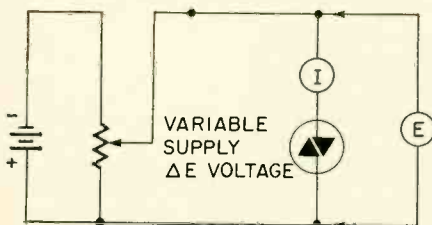

Fig. 2—VDR test setup. Rating is ratio of change in applied voltages required for a current change of 10.

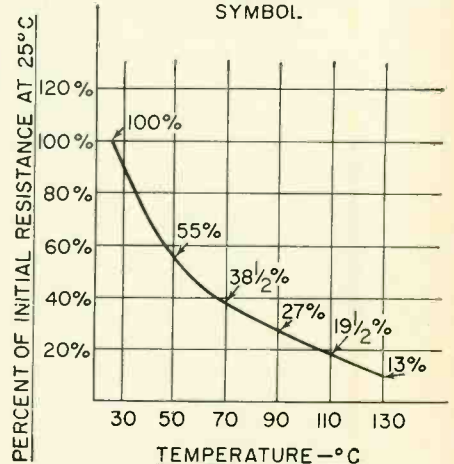
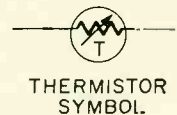

Fig. 3—Thermistor curve. Resistance drops as temperature rises.

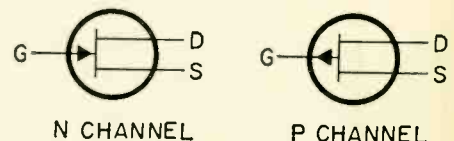

Fig. 4—Symbols for junction-type FET's. N-channel and p-channel types.

sidered good. Some thermistors have hot and cold values well into the megohm range.

When they fail, most thermistors increase in resistance. In a TV set this can cause slow warmup of series-string tubes, changes in vertical height with temperature or continuous degaussing in a color set.

The field-effect transistor

Appearing in new electronic circuitry is a new transistor type—the field-effect transistor or FET (see Fig. 4). Advantages include a high-impedance input, high-frequency response and low noise level. There is excellent input-output isolation, which is a common shortcoming of most transistors. There are two basic types: junction FET's and insulated-gate FET's.

The basic operation of the junction FET (JFET) can be described as an electrostatic field control of current flowing through a semiconductor (see Fig. 5). The input signal provides a controlling field to the gate terminal to regulate the flow of electrons from drain to source. If the gate bias is reversed with respect to the drain source, current is reduced. If gate bias is of forward polarity, drain-source current increases. The gate bias thus varies the depletion region, reducing the channel conduction size and increasing the resistance of the channel to current flow.

With a small gate voltage we can control a large source-drain current, so we have the ingredients of an amplifier. In Fig. 5 a high-impedance transformer secondary applies a small rf signal to a JFET. As shown, an oscillator signal is injected at the cur-

rent-source terminal to use the stage as a superheterodyne rf-oscillator mixer.

The gate terminal must never be completely forward-biased or the source-drain current will flow into the gate circuit.

Insulated gate FET

This type FET has the gate junction insulated from the current-drain material by glass. This prevents drain current from flowing into the gate circuit as it did in the JFET. The principle of operation is the same as the JFET except that a higher input impedance is obtained and the dc polarity of the input signal may vary. To set up a dc operating condition, a positive polarity is applied to the drain terminal (Fig. 6). The substrate is connected to the source, and both are at ground potential so the channel electrons are attracted to the positive drain and a dc source-drain current is obtained.

Silicon controlled rectifiers

The Silicon Controlled Rectifier (SCR) is similar to the vacuum-tube thyatron. When a voltage is placed across the anode and cathode a trigger voltage applied to the gate causes the semiconductor layers to suddenly decrease in resistance and heavy current can flow. This continues even after the gate trigger voltage is removed and as long as the cathode-anode voltage remains.

A typical SCR application is as a switch to turn on a stereo indicator lamp in an FM set. In this circuit the 19-KHz subcarrier signal, which is present only during stereo reception, is used to turn on the SCR so that the

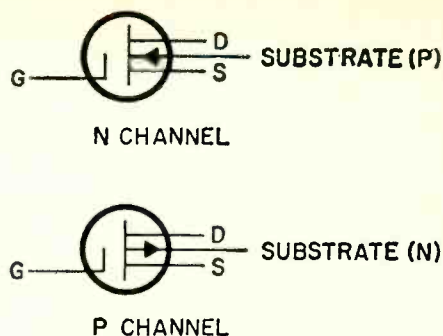

Fig. 6—Electronic symbols for the IGFET or insulated-gate FET. This type has a higher input impedance than the JFET and does not load down a signal source.

6.3 volts ac can operate the lamp. When stereo reception stops, the trigger voltage is removed and the anode-to-cathode current is shut off after the first pass of the ac voltage through zero.

Varactor diodes

A varactor or variable-reactance diode is a pn junction semiconductor device in which the junction capacitance varies in relation to the junction voltage. When biased in the reverse direction, a varactor diode can be represented by a voltage-sensitive capacitance in series with a resistance. This nonlinear capacitance and low series resistance permit the device to perform frequency-multiplication, oscillation and switching functions. It is the result of a very high impurity concentration outside the depletion-layer region and a relatively low concentration at the junction. Very low noise levels are possible in circuits using varactor diodes because the main current across the junction is reactive and random-noise components are absent.

A practical application of the varactor diode is shown in Fig. 7. The circuit permits automatic frequency control by applying an afc voltage to the cathode of the varactor diode.

A fixed bias voltage is maintained on diode SC2 by resistors R38 and R40. The diode remains in a reverse-biased condition while afc voltage variations cause slight capacitance changes, maintaining a constant oscillator frequency.

Clamping and rectifying diodes

Rectifying diodes are often used as polarity switches, rectifiers and overload limiting devices. One application is as a source of dc restoration in a TV set and bias for brightness control (see Fig. 8).

In this circuit SC202 rectifies a flyback pulse so that positive pulses forward-bias the diode and pull elec-

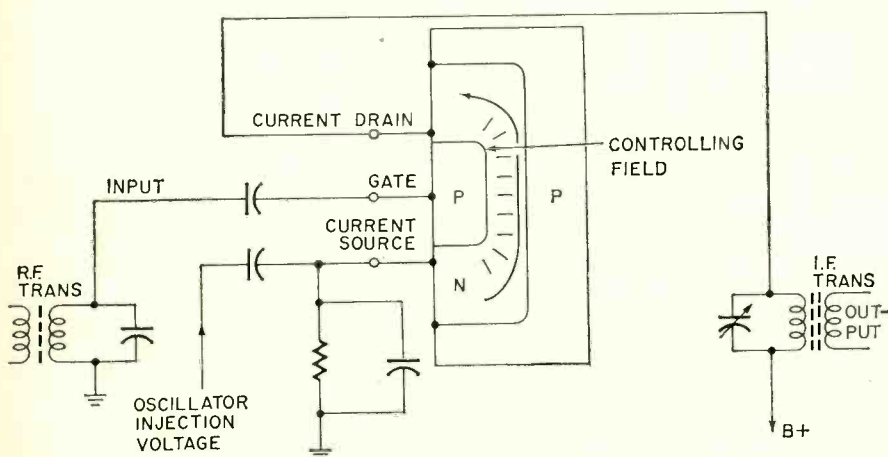

Fig. 5—With its inherent high input impedance, the junction field-effect transistor makes an ideal rf or i.f. amplifier. A large current between drain and source can be controlled by a small voltage on the gate. When an rf voltage of a different frequency is fed to source, the FET makes a good heterodyne mixer.

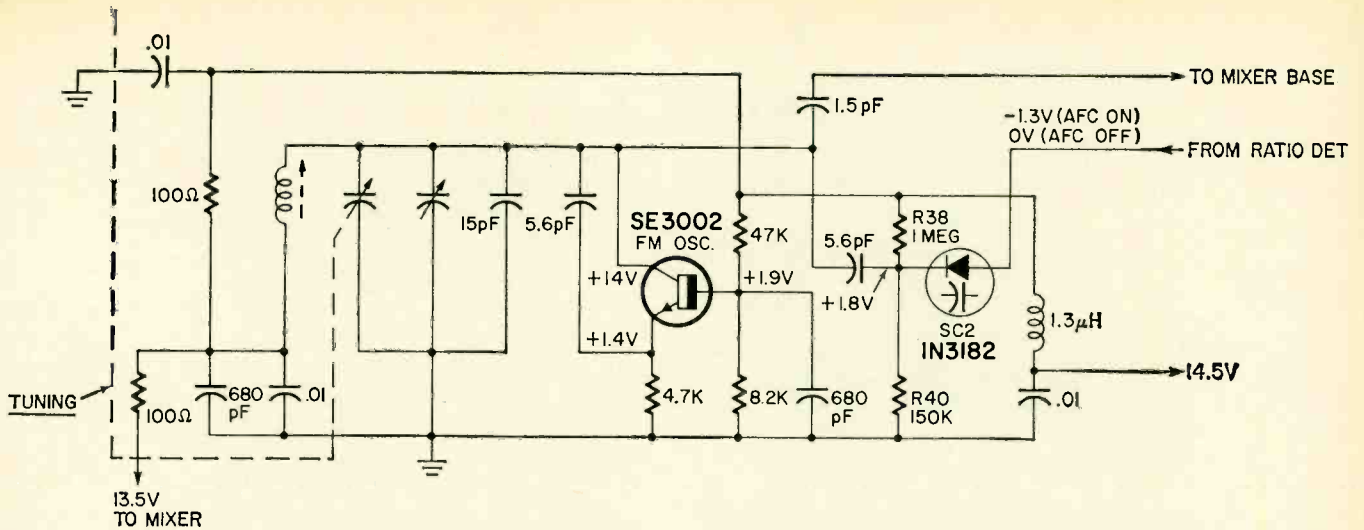

Fig. 7—In this FM afc circuit, the capacitance of the back-biased varactor is across the oscillator tank. Mistuning or drift causes the FM detector to develop a negative correc-

tion voltage on the varactor anode. This changes the effective oscillator capacitance in the direction that restores the oscillator to the correct operating frequency.

trons up from ground. This negative charge is drained off to ground through the BRIGHTNESS control. Depending on the control setting, the adjusted bias is applied to the grid of the video output stage and sets its conduction level. This establishes video plate voltages and in turn the CRT cathode bias.

In series with the voltage developed by the brightness circuit is another voltage developed by rectified flyback pulses and video signal. The flyback pulse provides positive-going pulses to turn on SC204 and remove electrons from the video output grid. This is done at a level determined by the flyback pulse amplitude. When a negative polarity video signal is present, the average dc bias on the grid of V7 varies to match and the corresponding conduction change and adjusts CRT cathode bias. The CRT bias is therefore dependent upon the average video signal level.

A receiver may use a clamping diode circuit to reduce the gain of an i.f. section when very strong signals are received. Normally the diode is reverse-biased until a large signal causes the diode to conduct.

When the diode conducts, it loads the transformer and gain drops considerably. To troubleshoot this circuit, make sure the diode is reverse-biased under no-signal conditions. The anode of the overload diode should be negative with respect to the cathode by a volt or more with no signal. A shorted diode causes a severe gain reduction under any signal condition. An open diode results in distortion when very strong signals are received.

Another application of the clamping diode is in a vertical oscillator cir-

cuit (see Fig. 9). This is a multivibrator type circuit with vertical triggering applied at the cathode of the vertical oscillator and across a diode. The diode is forward-biased to allow the tube to conduct normally. When sync pulses are applied to the diode, negative-going pulses bias the cathode and

serve to trigger the tube out of the cutoff portion of its cycle. Positive-going pulses are grounded by virtue of forward-biasing the clamping diode. The diode will keep the cathode potential of V13-a from ever going positive, but will allow negative excursions resulting from sync pulses. R-E

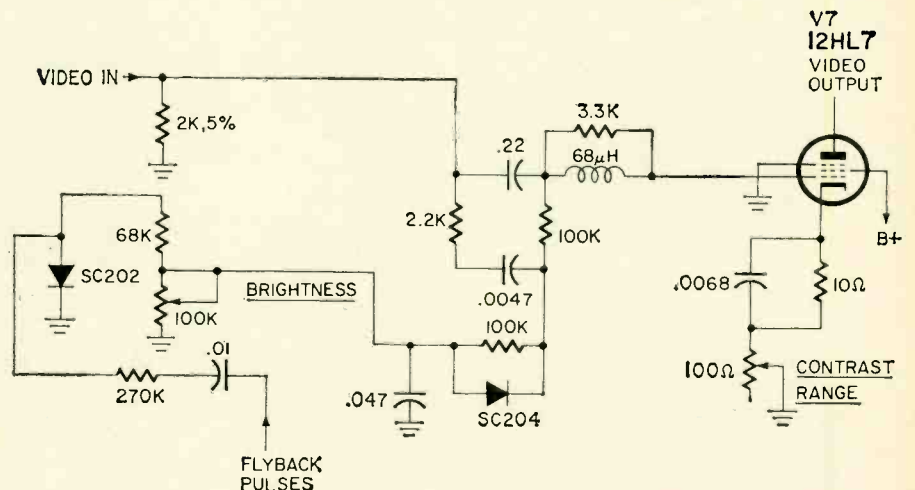
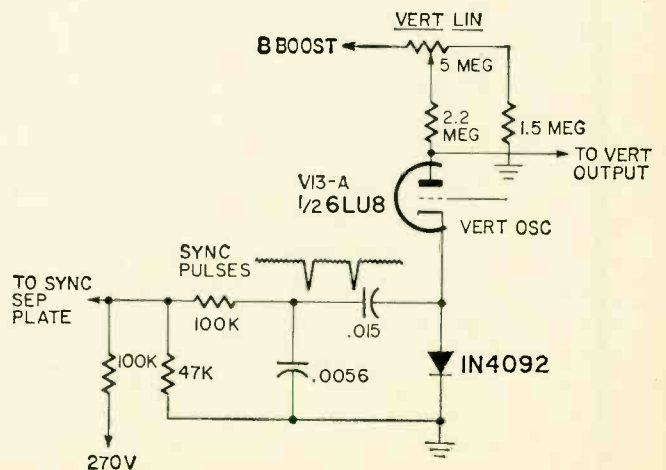

Fig. 8—Sylvania uses diodes for dc restoration and automatic brightness control in some sets.

Fig. 9—Diode in cathode circuit insures that the vertical oscillator is triggered only by the negative-going part of the sync pulse.



VARIABLE-VOLTAGE TUNING

A new kind of tuning "capacitor" for the new sets

by **ROBERT F. SCOTT**
SENIOR TECHNICAL EDITOR

DURING THE EVOLUTION OF RADIO communications, the galena crystal and spark gap gave way to vacuum tubes and now the vacuum tube is rapidly being replaced by semiconductors. The variable tuning capacitor—which, except for permeability tuning in auto radios, seemed to be forever with us—is now bowing out in favor of a solid-state equivalent. These semiconductors that are replacing the tuning capacitor are generally known as voltage variable capacitance (VVC) diodes, varactors, voltage variable diodes or capacitance diodes and by such trade names as Varicaps, Epicaps, Minicaps, Voltacaps, Capi-stors and Varactrons.

The VVC is a special type of silicon diode that acts like a capacitor when its pn junction is back-biased. The effective capacitance of a diode varies as the formula $1/\sqrt{V}$ as the voltage across its terminals is varied. The capacitance versus bias voltage curve for a typical VVC diode is shown in Fig. 1.

There doesn't seem to be a standard symbol for the VVC. Some of the more common ones are shown in Fig. 2.

The earlier VVC's had a low maximum capacitance and a maximum capacitance ratio of around 5.5:1 which limited their use to modulation and afc circuits. Recently, high-Q VVC's have been developed with capacitance ratios greater than

26:1 for a voltage range of 0 to 10 volts. This makes it possible to use them as replacements for the conventional mechanical variable capacitor tuning over as much as a 3 to 1 frequency range of any band on a receiver or signal generator. The VVC offers many advantages over its conventional mechanical equivalent. Among them are:

- Small size—they average around 0.1 inch in diameter and 0.3 inch long.
- No need for mechanical coupling to dial or drive mechanism.
- High-speed tuning.
- Greater electrical stability because of immunity to shock and vibration.
- No moving parts to wear out or come loose.
- Temperature coefficients are known and easily compensated.
- Tuning controls (a potentiometer or pushbutton switch to adjust the dc bias) can be remote from the tuner.

VVC front-end for AM radio

VVC diodes have been used for tuning and bandswitching in some European TV sets and in some Japanese and European AM/FM radios since around 1964. The front-end (converter) of a pushbutton AM tuner is shown in Fig. 3. It was described in an application note for the BA 163 made by ITT.

The BA 163 is a silicon epitaxial diode with a capacitance ratio of greater than 26:1 over a voltage range of 0 to 10 volts. Its Q ranges from 200 (minimum) to 500 (typical) from 150 to 500 kHz at 1 volt and from 300 to 1500 kHz at 10 volts.

In the diagram, one BA 163 is connected in series with a .047- μ F capacitor across the high-impedance winding of a ferrite-type antenna coil. The series capacitor blocks the dc control voltage and prevents it from shorting to ground. Its value is high enough so it does not affect the capacitance range of the VVC. C1-L1 form a trap to reject signals in the set's i.f. range.

The oscillator circuit works in the common-base mode with feed-

back from collector to emitter. The oscillator voltage in the collector circuit is limited (by design) to 1 volt p-p to limit distortion.

Antenna-tuning diode D1 is fed from the 10-volt bias line through an adjustable voltage divider consisting of R3 and R4, and the oscillator diode is fed from a fixed voltage divider consisting of R1, R2 and R4. R3 is adjusted for proper tracking between the oscillator and antenna circuits.

The bias voltage for the tuning diodes is applied through interlocking pushbutton switches S1–S6. When S1 is closed, R5 is used for continuous tuning. Switches S2–S6 and pots R6–R10 are for preset pushbutton tuning. Potentiometer R11 sets the maximum bias voltage developed across the control pots.

The BA 163 is supplied in matched sets of 2, 3, 4 or as is required. For any two, the maximum ratio of voltages at 30 pF is 1:1. The basic tracking circuit for any two diodes is shown in Fig. 4. Potentiometers R1 and R2 are set so the capacitance of D1 and D2 is 30 pF. The capacitance ranges that can be obtained by varying voltage V_{ab} (with R1) are 120–260 pF, 30–120 pF and 10–30 pF. When the ratio of the voltages across D1 and D2 is constant, the capacitance differential is less than 5% from 120 to 260 pF, less than 2% in the 30–120-pF range and less than 1 pF between 10 and 30 pF.

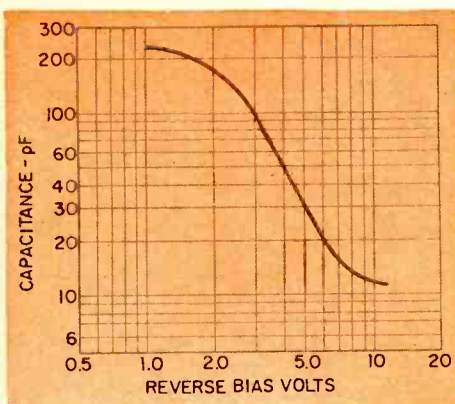

Fig. 1—Capacitance vs reverse voltage curve for VVC. Nominal capacitance is the value obtained with 4 volts of reverse bias.

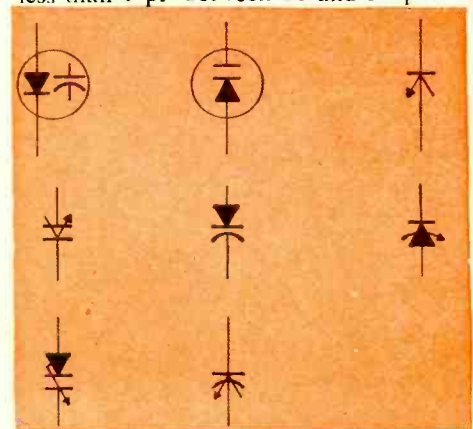

Fig. 2—There is no common VVC symbol. Here are the most common ones in use. R-E uses the one shown at right in bottom row.

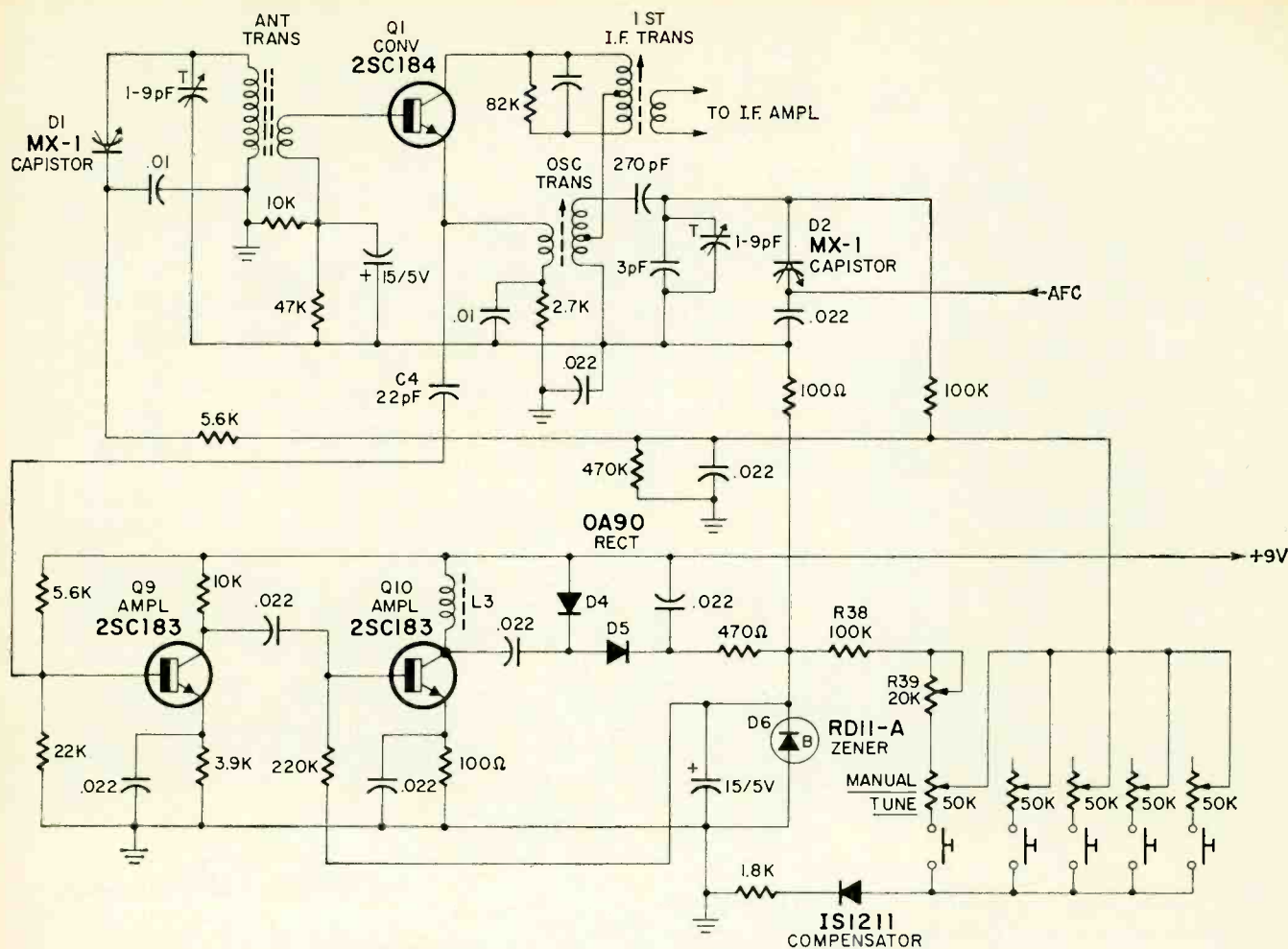

Fig. 6—Front-end and voltage-regulator circuit in the Panasonic R-1500 battery-powered transistor portable radio. The oscillator voltage is tapped off, amplified, rectified and then added to supply voltage to compensate for low batteries.

Oscillator coil L6 is shunted by varactors D5 and D6 connected back-to-back and tied to the tuning bus. (In the oscillator circuit, the rf voltage across the tank coil is high compared to the tuning voltage applied to the varactors. If a single diode were used as in the antenna and mixer tuned circuits, this high rf voltage would lead to frequency instability and high harmonic output. With two varactors back-to-back, the dc tuning bias varies the capacitance of both by the same amount and in the same direction—as with a split-stator capacitor—while the rf voltage causes equal and opposite capacitance changes.)

The channel selector consists of a special two-section potentiometer (R2-R3) ganged to bandswitch S1. As the arm of the channel selector is moved to the right (toward the junction of R2 and R4) the voltage applied to D2, D4, D5 and D6 goes more positive. This decreases their effective capacitance and tunes the antenna, mixer and oscillator circuits to successively higher channels in the vhf band.

Coils L2, L3 and L5 are isolated

from the circuit during vhf operation by the very low effective capacitance of D1, D3 and D7 which is produced by the negative bias on the switching bus.

As the arm of the channel selector passes the mid-point of its travel, it moves to the junction of R3 and R5 and S1 switches to the high position. D1, D3 and D7 are now forward-biased so they act as short circuits or closed switches which connect L2, L3 and L5 in parallel with the vhf coils. This reduces the effective inductance in the antenna, mixer and oscillator circuits so the uhf channels can be covered.

Battery portables too

When VVC tuning was applied to the Panasonic R-1500 battery-powered transistor portable, special circuits were added to insure that a stable 10 volts was available for the Capistors (D1 and D2) in the antenna and mixer circuits so as to compensate for the normal decrease in battery voltage with time and use. The front end and compensating circuits in the R-1500 are in Fig. 6. The

set has five pushbuttons: one to select manual tuning and four for pre-set stations.

When the set is first turned on, battery current from the 9-volt line flows through D4 and D5 and turns on converter Q1. As Q1 starts oscillating, a part of the oscillator voltage is tapped off the emitter circuit and fed through C4 to the base of Q9. Transistors Q9 and Q10 amplify the oscillator signal and develop a fairly high rf voltage across rf choke L3.

This voltage is rectified by D4 and D5 and added to the converter supply voltage and stabilized by Zener diode D6. This stabilized voltage is also fed through R38 and R39 to the manual tuning or preset pots as bias for the Capistors in the antenna and mixer circuits.

The afc circuit (not shown) consists of a separate i.f. amplifier stage—fed from the output of the second i.f. amplifier—feeding a discriminator that develops a correction voltage. This voltage is applied to the anode of the oscillator Capistor (D2) to aid or oppose the tuning bias and tune the station in right on the nose. **R-E**

The New 1969 Improved Model 257 **A REVOLUTIONARY NEW TUBE TESTING OUTFIT**

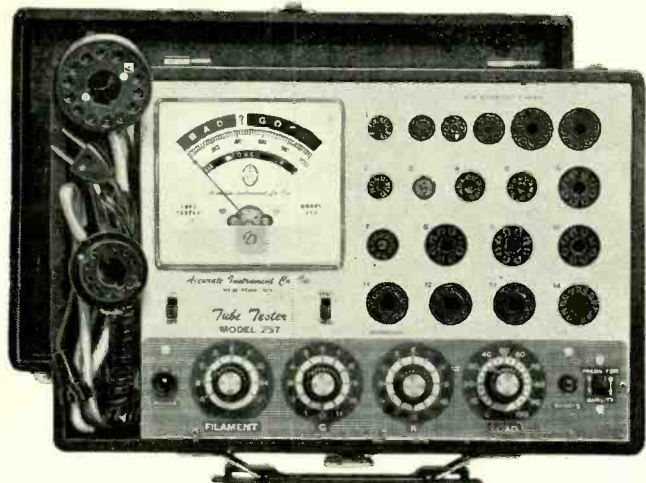

COMPLETE WITH ALL ADAPTERS AND ACCESSORIES, NO "EXTRAS"

STANDARD TUBES:

- ✓ Tests the new Novars, Nuvistors, 10 Pins, Magnovals, Compactrons and Decals.
- ✓ More than 2,500 tube listings.
- ✓ Tests each section of multi-section tubes individually for shorts, leakage and Cathode emission.
- ✓ Ultra sensitive circuit will indicate leakage up to 5 Megohms.
- ✓ Employs new improved 4½" dual scale meter with a unique sealed damping chamber to assure accurate, vibration-less readings.
- ✓ Complete set of tube straighteners mounted on front panel.

The Model 257 is housed in a handsome, sturdy, portable case. Comes complete with all adapters and accessories, ready to plug in and use. No "extras" to buy. Only

BLACK AND WHITE PICTURE TUBES:

- ✓ Single cable used for testing all Black and White Picture Tubes with deflection angles 50 to 114 degrees.
- ✓ The Model 257 tests all Black and White Picture Tubes for emission, inter-element shorts and leakage.

COLOR PICTURE TUBES:

- ✓ The Red, Green and Blue Color guns are tested individually for cathode emission quality, and each gun is tested separately for shorts or leakage between control grid, cathode and heater. Employment of a newly perfected dual socket cable enables accomplishments of all tests in the shortest possible time.

\$47⁵⁰

NOTICE

We have been producing radio, TV and electronic test equipment since 1935, which means they were making Tube Testers at a time when there were relatively few tubes on the market, way before the advent of TV. The model 257 employs every design improvement and every technique learned over an uninterrupted production period of 32 years.

Accurate Instrument Co., Inc.

SEND NO MONEY WITH ORDER PAY POSTMAN NOTHING ON DELIVERY

Try it for 10 days before you buy. If completely satisfied then send \$10.00 and pay the balance at the rate of \$10.00 per month until the total price of \$47.50 (plus P.P., handling and budget charge) is paid. If not completely satisfied, return to us, no explanation necessary.

ACCURATE INSTRUMENT CO., INC.

Dept. 641 2435 White Plains Road, Bronx, N. Y. 10467

Please rush me one Model 257. If satisfactory I agree to pay \$10.00 within 10 days and balance at rate of \$10.00 per month until total price of \$47.50 (plus P.P., handling and budget charge) is paid. If not satisfactory, I may return for cancellation of account.

Name _____

Address _____

City _____ Zone _____ State _____

Save Money! Check here and enclose \$47.50 with this coupon and we will pay all shipping charges. You still retain the privilege of returning after 10 day trial for full refund.

Circle 23 on reader service card

"CIE training helped pay for my new house," says Eugene Frost of Columbus, Ohio

Gene Frost was "stuck" in low-pay TV repair work. Then two co-workers suggested he take a CIE home study course in electronics. Today he's living in a new house, owns two cars and a color TV set, and holds an important technical job at North American Aviation. If you'd like to get ahead the way he did, read his inspiring story here.



IF YOU LIKE ELECTRONICS—and are trapped in a dull, low-paying job—the story of Eugene Frost's success can open your eyes to a good way to get ahead.

Back in 1957, Gene Frost was stalled in a low-pay TV repair job. Before that, he'd driven a cab, repaired washers, rebuilt electric motors, and been a furnace salesman. He'd turned to TV service work in hopes of a better future—but soon found he was stymied there too.

"I'd had lots of TV training," Frost recalls today, "including numerous factory schools and a semester of advanced TV at a college in Dayton. But even so, I was stuck at \$1.50 an hour."

Gene Frost's wife recalls those days all too well. "We were living in a rented double," she says, "at \$25 a month. And there were no modern conveniences."

"We were driving a six-year-old car," adds Mr. Frost, "but we had no choice. No matter what I did, there seemed to be no way to get ahead."

Learns of CIE

Then one day at the shop, Frost got to talking with two fellow workers who were taking CIE courses... pre-

paring for better jobs by studying electronics at home in their spare time. "They were so well satisfied," Mr. Frost relates, "that I decided to try the course myself."

He was not disappointed. "The lessons," he declares, "were wonderful—well presented and easy to understand. And I liked the relationship with my instructor. He made notes on the work I sent in, giving me a clear explanation of the areas where I had problems. It was even better than taking a course in person because I had plenty of time to read over his comments."

Studies at Night

"While taking the course from CIE," Mr. Frost continues, "I kept right on with my regular job and studied at night. After graduating, I went on with my TV repair work while looking for an opening where I could put my new training to use."

His opportunity wasn't long in coming. With his CIE training, he qualified for his 2nd Class FCC License, and soon afterward passed the entrance examination at North American Aviation. "You can imagine how I felt," says Mr. Frost. "My new job paid \$228 a month more!"

Currently, Mr. Frost reports, he's an inspector of major electronic systems, checking the work of as many as 18 men. "I don't lift anything heavier than a pencil," he says. "It's pleasant work and work that I feel is important."

Changes Standard of Living

Gene Frost's wife shares his enthusiasm. "CIE training has changed our standard of living completely," she says.

"Our new house is just one example," chimes in Mr. Frost. "We also have a color TV and two good cars instead of one old one. Now we can get out and enjoy life. Last summer we took a 5,000 mile trip through the West in our new air-conditioned Pontiac."

"No doubt about it," Gene Frost concludes. "My CIE electronics course has really paid off. Every minute and every dollar I spent on it was worth it."

Why Training is Important

Gene Frost has discovered what many others never learn until it is too late: that to get ahead in electronics today, you need to know more than soldering connections, testing circuits, and

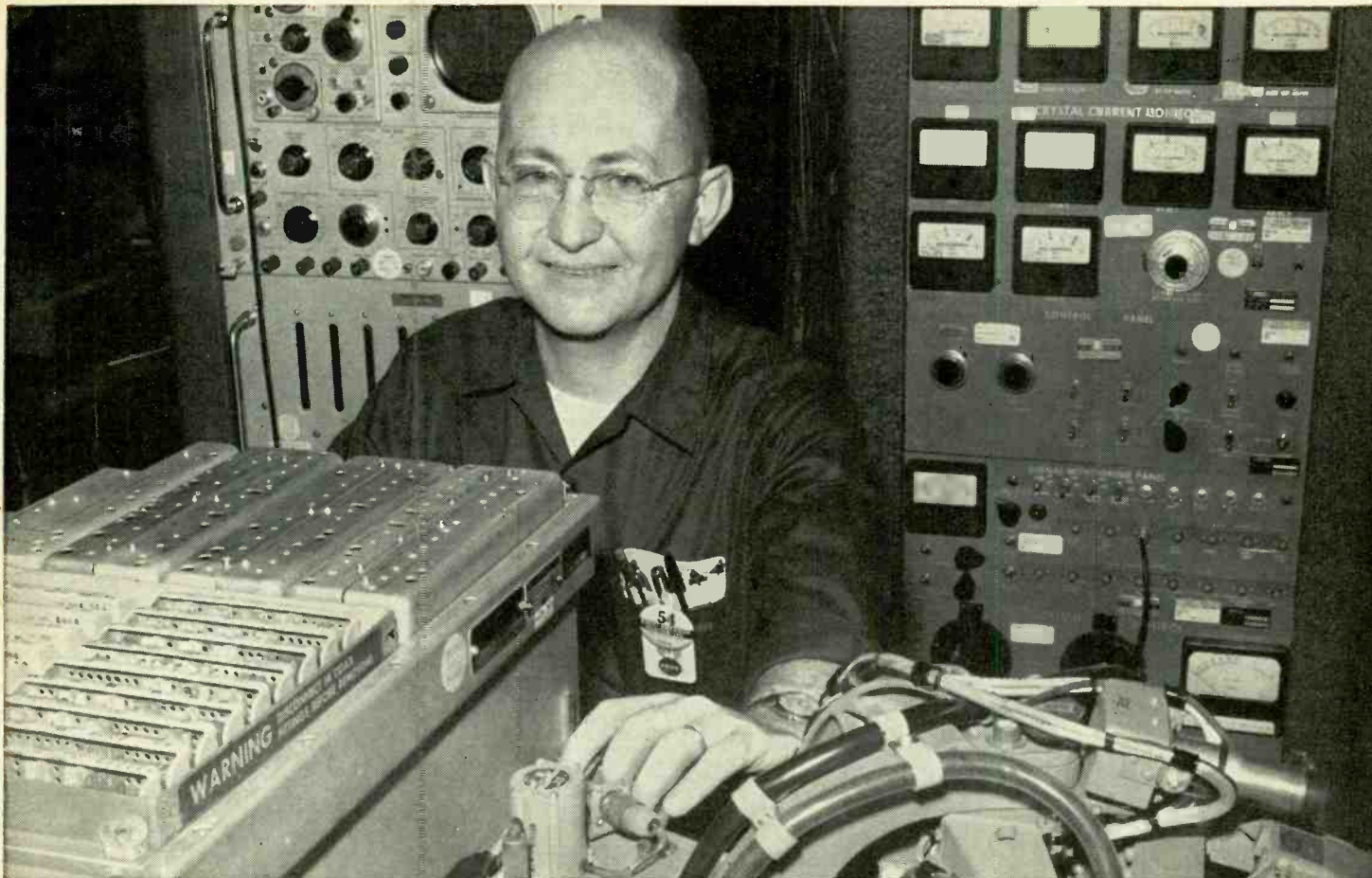

replacing components. You need to really know the fundamentals.

Without such knowledge, you're limited to "thinking with your hands" ... learning by taking things apart and putting them back together. You can never hope to be anything more than a serviceman. And in this kind of work, your pay will stay low because you're competing with every home handyman and part-time basement tinkerer.

But for men with training in the fundamentals of electronics, there are no such limitations. They think with their heads, not their hands. They're qualified for assignments that are far beyond the capacity of the "screw-driver and pliers" repairman.

The future for trained technicians is bright indeed. Thousands of men are desperately needed in virtually every field of electronics, from 2-way mobile radio to computer testing and troubleshooting. And with demands like this, salaries have skyrocketed. Many technicians earn \$8,000, \$10,000, \$12,000 or more a year.

How can you get the training you need to cash in on this booming demand? Gene Frost found the answer in CIE. And so can you.

Send for Free Book

Thousands who are advancing their electronics careers started by reading our famous book, "How To Succeed In Electronics." It tells of the many electronics careers open to men with the proper training. And it tells which courses of study best prepare you for the work you want.

If you'd like to get ahead the way Gene Frost did, let us send you this 44-page book free. With

it we'll include our other helpful book, "How To Get A Commercial FCC License." Just fill out and mail the attached card.

If the card is missing, use the coupon below.

ENROLL UNDER G.I. BILL

All CIE courses are available under the new G.I. Bill. If you served on active duty since January 31, 1955, or are in service now, check box on reply card for G.I. Bill information.

CIE Cleveland Institute of Electronics
1776 East 17th Street, Cleveland, Ohio 44114

NEW

COLLEGE-LEVEL CAREER COURSE FOR MEN WITH PRIOR EXPERIENCE IN ELECTRONICS

ELECTRONICS ENGINEERING ... covers steady-state and transient network theory, solid state physics and circuitry pulse techniques, computer logic and mathematics through calculus. A college-level course for men already working in Electronics.

Cleveland Institute of Electronics
1776 East 17th Street, Cleveland, Ohio 44114

Please send me without cost or obligation:

1. Your 44-page book "How To Succeed In Electronics" describing the job opportunities in Electronics today, and how your courses can prepare me for them.
2. Your book on "How To Get A Commercial FCC License."

I am especially interested in:

- | | | |
|--|---|--|
| <input type="checkbox"/> Electronics Technology | <input type="checkbox"/> Broadcast Engineering | <input type="checkbox"/> First Class FCC License |
| <input type="checkbox"/> Electronic Communications | <input type="checkbox"/> Industrial Electronics | <input type="checkbox"/> Electronics Engineering |

Name _____ (Please Print)

Address _____

City _____ State _____ Zip _____

Check here for G.I. Bill information.

RE-59

Circle 24 on reader service card

PERFORM WITH CHAMPIONS



ONLY \$44.95 ppd.

BUY THE BEST MARK TEN[®] CAPACITIVE DISCHARGE IGNITION SYSTEM

DELTAKIT only \$29.95
ASSEMBLE IT YOURSELF!

Now discover for yourself the dramatic improvement in performance of your car, camper, jeep, truck, boat — any vehicle! Delta's remarkable electronic achievement saves on gas, promotes better acceleration, gives your car that zip you've always wanted. Find out why even Detroit has finally come around. In four years of proven reliability, Delta's Mark Ten has set new records of ignition benefits. No re-wiring! Works on literally any type of gasoline engine.

COMPARE THESE PROVEN BENEFITS...

- ▲ Dramatic Increase in Performance and in Fast Acceleration
- ▲ Promotes more Complete Combustion
- ▲ Points and Plugs last 3 to 10 Times Longer
- ▲ Up to 20% Mileage Increase (saves gas)

Order Your MARK TEN Today
Shipped Postpaid at once . . .



DELTA PRODUCTS, INC. DP 9-6

P.O. Box 1147 RE • Grand Junction, Colo. 81501
Enclosed is \$ _____ Ship ppd. Ship C.O.D.
Please send:

- Mark Tens (Deltakit[®]) @ \$29.95
(12 VOLT POSITIVE OR NEGATIVE GROUND ONLY)
 Mark Tens (Assembled) @ \$44.95
 6 Volt: Negative Ground only Positive Ground
 12 Volt: Specify Negative Ground

Car Year _____ Make _____
Name _____
Address _____
City/State _____ Zip _____

Circle 16 on reader service card

NEW BOOKS

KNOW YOUR TUBE AND TRANSISTOR TESTERS, by Robert G. Middleton. *Howard W. Sams & Co., Inc., 4300 W. 62 St., Indianapolis, Ind. 46206. 5 3/4" x 8 1/2" in., 144 pages, soft cover, \$3.50.*

Covers principles of tube and transistor testers and circuits used in them. Typical service and lab-type testers are analyzed. Furnishes background necessary for troubleshooting and repairing various testers.

ELECTRONIC DIGITAL TECHNIQUES by Paul M. Kinter. *McGraw-Hill Book Co., 330 W. 42 St., N.Y., N.Y. 10036. 9 1/4" x 6 1/4". 315 pp, hard cover, \$11.95.*

A down-to-earth approach to digital systems geared to the needs of the practicing engineer. Non mathematical guide is concerned only with actual design problems and the techniques for their solutions.

ELECTRONIC CIRCUITS, by Samuel Seely. *Holt, Rinehart & Winston, Inc., 383 Madison Ave., New York, N. Y. 10017. 6 1/4" x 9 1/4", 752 pp. Cloth, \$13.95*

This text introduces the theoretical and practical aspects of semiconductor and tube circuits. It explains how an FET is often used without basic changes in a normal tube circuit configuration. Circuit discussion includes small signal untuned amplifiers, analog computing circuits, sinusoidal oscillators, sawtooth generators, integrated circuits and power supplies.



THE BOSS'LL BE FURIOUS. YOU BENT THE ANTENNA.

TRANSISTOR TROUBLESHOOTING PRECAUTIONS

Be careful when working with transistors. They can be destroyed almost instantly.

Do not work on transistor equipment with power connected. The only time you should have power on is when the equipment is operating or when you are making measurements.

Do not probe energized circuitry. A momentary short from base to collector will almost always destroy a transistor. In direct-coupled stages other transistors may be destroyed as well. Guard against dropped tools, too. In the time it takes a screwdriver to glance off a pair of terminals a transistor may be destroyed.

Clean all foreign materials off the insulators when replacing power transistors. Such particles can pierce the mica insulator or prevent adequate heat transfer to the heat sink.

Apply silicone grease on both sides of the mica insulator used with power transistors.

When soldering transistors, use a heat sink whenever possible and keep heat application time short.

Use only test equipment which is well isolated from the line when making measurements on a chassis which is connected to a power source (even though the switch is turned off). Check all test equipment and use an isolation transformer on the chassis under test if necessary.

Do not use just any ohmmeter to check resistance in transistor chassis. The voltage at the leads of some ohmmeters may exceed the current or voltage limitations of the transistors. Usually, the lower resistance scales on 20,000 ohm/volt meters are safe for short and open tests.

Do not arc high voltage haphazardly. Arcing can cause small-signal transistor failure.

Do not shunt capacitors without fully understanding the circuits. Shunting can cause transistor failure.

Do not operate the TV with the yoke disconnected.

Do not operate the set with the speaker disconnected.

Many transistor stages are direct-coupled. A malfunction in one stage can cause improper readings elsewhere. **R-E**

Our tubes have finally met their match.

We've been making power output tubes for a long time.

Now, we're matching them.

You can get the most popular output tubes—6BQ5, 7591A, 7868, and 8417—in carefully matched pairs.

Matched pairs that lower harmonic distortion, reduce hum.

And give you more satisfied customers.

Sylvania is the only domestic brand that your distributor has in stock. Just ask for 6BQ5P, 7591P, 7868P, or 8417P. The suffix "P" assures you that you are getting a set of tubes factory-matched by Sylvania.

Sylvania Electronic Components, Electronic Tube Division, West Third St., Emporium, Pa. 15834.



SYLVANIA
A SUBSIDIARY OF
GENERAL TELEPHONE & ELECTRONICS

Circle 25 on reader service card

The brand for all reasons



Every BSR McDonald automatic turntable is precision made in Great Britain to the most exacting specifications. Upon their arrival in the U.S., every model is unpacked and re-tested under actual playing conditions. That's why BSR service calls are the lowest in the industry—and perhaps that also explains why BSR sells more turntables than anyone else in the world.



McDONALD

P
BSR (USA) LTD.
BLAUVELT, N.Y. 10913
Please send FREE detailed literature
on all BSR McDonald automatic turntables.

Name

Address

City

State

Zip

Circle 26 on reader service card

Short-Wave Tuning Aid

SOME OLDER RECEIVERS ARE HARD TO tune to an exact frequency. You log a foreign station one night, but cannot find it the next night because the dial is critical to manage, and because the frequency drifts.

This crystal oscillator uses a crystal in the i.f. range, about 400 or 450 kc. (Make sure its at least 10–15 kc away from the set's i.f.) The wide span between harmonics produces less confusion and maintains a stronger signal, than a 10-kc oscillator.

As an application example, consider the SX-71 (popular about 12 years ago.) Its bandspread is calibrated for the ham bands, and it also carries a 0–100 logging scale. The main dial is correctly calibrated in mc *only* when the bandspread dial is at 100. The bandspread calibrations are correct *only* when the main dial is on the desired band marking.

Assume you place a 474-kc crystal in the calibrator circuit. You wish to tune the receiver to the 7-mc ham band. The closest harmonic of 474 kc is 7.1 mc (the 15th harmonic). So you set the bandspread to 7.1 and tune near the 40-meter marker on the main dial till you hear the oscillator signal. The bandspread dial is now correctly calibrated for the band.

The oscillator helps you tune short-wave broadcasts and other signals, too. Say you wish to scan the 6-mc region. The closest harmonics of 474 kc are the 12th (5.7 mc) and the 13th (6.2 mc). Set bandspread to 100 and tune the main dial for 6.2 *approximately*, till you pick up the oscillator. Unless your dial is badly in error, it will point to near 6.2 mc. Now search for stations with the bandspread, logging as you find them.

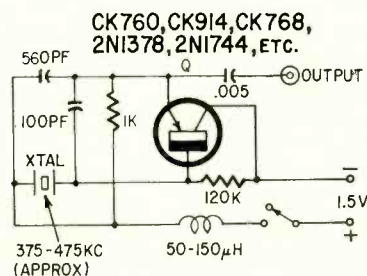

The diagram shows some of the transistor types found suitable for the circuit. Low-frequency types are not suitable. Sluggish transistors may require a 3-volt battery. Total current drain is less than 0.5 ma. The output terminal connects to or near the antenna post of the receiver.—I. Queen **R-E**

COMING NEXT MONTH

You'll find two special roundup features in our exciting May issue. If you're a CB'er or operate a boat, don't miss:

- **CB Radio Roundup**—What's happened to 1969 transceivers? Frequency synthesis, mechanical filters, FET's and IC's are just part of the story.

- **Electronics Afloat**—Sophisticated electronics is no longer limited to yachts. Here's a look at new devices that bring safety and convenience to boating.

PLUS THESE FEATURES

- **IC Stereo Preamp**—Start on part two of R-E's "last word" stereo system. This month we describe our 125-watt per channel amplifier. Feed signals to it with this professional preamp.

- **Build a 50-Watt Booster Ampl**—Turn a low-wattage guitar amplifier into a setup that'll shake the walls.

May Radio-Electronics

The cartridge looms large for a simple reason:

It is the point of contact between the entire hi-fi system and the recording. What happens at the tip of its tiny stylus determines what will happen in all those big and impressive components that are so obvious to the eye and, in the aggregate, so apparent to the pocketbook. Worldwide, experts and critics have hailed the discovery of Trackability as *the* definitive measurement of cartridge performance. When evaluated against this measurement, the superb **Shure V-15 Type II Super Track** stands alone. Shure Brothers, Inc., 222 Hartrey Ave., Evanston, Illinois 60204

The analog-computer-designed Shure V-15 Type II Super-Trackability cartridge maintains contact between the stylus and record groove at tracking forces from $\frac{1}{4}$ to $1\frac{1}{2}$ grams throughout and beyond the audible spectrum (20-25,000 Hz). Independent critics say it will make all of your records, stereo and mono, sound better and last longer. Tracks 18 cm/sec. and up at 400 Hz; tracks 26 cm/sec. and up at 5,000 Hz; tracks 18 cm/sec. and up at 10,000 Hz. This minimum trackability is well above the theoretical limits of cutting velocities found in quality records. \$67.50.



EIGHT INSTRUMENTS IN ONE

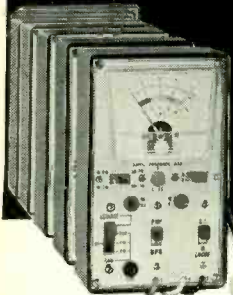

- Out-of-Circuit Transistor Analyzer
- Dynamic In-Circuit Transistor & Radio Tester
- Signal Generator
- Signal Tracer • Voltmeter
- Milliammeter
- Battery Tester
- Diode Checker

Transistor Analyzer Model 212

Factory Wired & Tested — \$19.50
Easy-to-Assemble Kit — \$13.50

YOU DON'T NEED A BENCH FULL OF EQUIPMENT TO TEST TRANSISTOR RADIOS! All the facilities you need to check the transistors themselves — and the radios or other circuits in which they are used — have been ingeniously engineered into the compact, 6-inch high case of the Model 212. It's the transistor radio troubleshooter with all the features found only in more expensive units. Find defective transistors and circuit troubles speedily with a single, streamlined instrument instead of an elaborate hook-up.

Features:

Checks all transistor types — high or low power. Checks DC current gain (beta) to 200 in 3 ranges. Checks leakage. Universal test socket accepts different base configurations. Identifies unknown transistors as NPN or PNP.

Dynamic test for all transistors as signal amplifiers (oscillator check), in or out of circuit. Develops test signal for AF, IF, or RF circuits. Signal traces all circuits. Checks condition of diodes. Measures battery or other transistor-circuit power-supply voltages on 12-volt scale. No external power source needed. Measures circuit drain or other DC currents to 80 milliamperes. Supplied with three external leads for in-circuit testing and a pair of test leads for measuring voltage and current. Comes complete with instruction manual and transistor listing.

EMC, 625 Broadway, New York 12, N. Y.

Send me **FREE** catalog of the complete value-packed EMC line, and name of local distributor.

NAME _____ RE-4

ADDRESS _____

CITY _____ ZONE _____ STATE _____

EMC

ELECTRONIC MEASUREMENTS CORP.
625 Broadway, New York 12, New York
Export: Pan-Mar Corp., 1270 B'way, N.Y. 1

Trouble: Poor Color

The set was brought in with a complaint of poor color. A check showed that the red field began to move diagonally toward the upper right corner of the screen as the set warmed up. The effect was more pronounced on the right side.

Troubleshooting, we let the set cool down and then played hot air from a hair dryer over the convergence board around diode block CR801 (see diagram). This caused the red field to misconverge a lot sooner. The diode

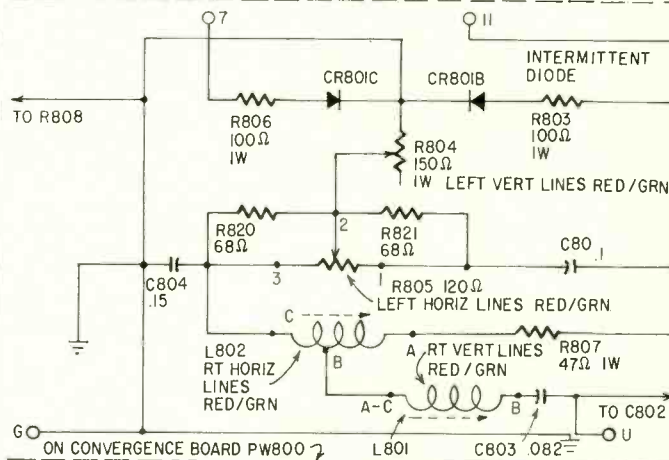

end of resistor R803 was jumpered to ground and the red field moved back in the direction of normal convergence. This showed that diode CR801B was intermittent—opening up when the diode block became sufficiently warm. The whole diode assembly must be replaced.—G. C. Heddle **RE**

FREE



GIANT 1969 RADIO-TV ELECTRONICS CATALOG

228 GIANT VALUE-PACKED PAGES

YOUR BUYING GUIDE FOR... TV's, Radios, Recorders, Phonos, Amateur and CB equipment, electronic parts, tubes and test equipment... plus featuring B-A's famous bargain packed section!

WRITE FOR YOUR FREE CATALOG TODAY!

BURSTEIN-APPLEBEE CO., Dept. RE-D
3199 MERCIER ST., KANSAS CITY, MO. 64111

Name _____

Address _____

City _____

State _____ Zip Code _____

Circle 30 on reader service card

IDEAL GIFT

(HAND-SIZED)

Gas Welding Torch

5000° Pinpoint Flame Welds, Brazes, Solders

(Self Contained. No wires or connections needed.)



Ideal for workshop, electrical/ electronic repair, labwork, miniature gasblowing, wiring, jewelry making.

FREE LITERATURE

MICROFLAME, INC.

Division of Printed Circuits, Inc.
7800 Computer Avenue, Dept. RE
Minneapolis, Minnesota 55424
Area 612 - 927-5681

Circle 31 on reader service card

RADIO-ELECTRONICS

TECHNOTES

SMALL SMALL-SCREEN PICTURE

An RCA 8PT7030 8-inch portable came into the shop with a 3-inch-square picture. Both vertical and horizontal sides were squeezed together.

All tubes were checked in the horizontal and vertical section. Replacement helped some but there was still a 1½-inch black edge around the picture.

The low-voltage power supply voltages compared favorably with those on the schematic. We checked the voltages in vertical and horizontal circuits and noticed that the vertical sweep supply voltage came from the

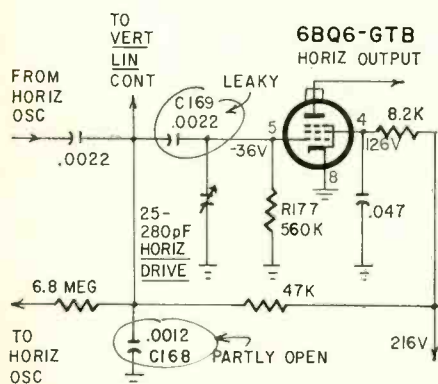

B+ boost supply. The B+ boost voltage was only 350, which was quite low.

Using a high-voltage probe, the picture-tube anode voltage was measured at 3,500. It should be 5,800 volts. The horizontal drive voltage was a -20 volts and should have been -36. Further checking, after replacing the 6C67 and 6BQ6 horizontal tubes, showed capacitor C169 was leaking. This capacitor was replaced and picture width was improved but was not perfect. The .0012- μ f capacitor, C168, was found to be partly open. Replacing it gave us a picture that filled the screen.—Homer L. Davidson

OLYMPIC CTC-400 SERVICE HINTS

Symptom: High-pitched sound that appears to come from the flyback transformer.

Cure: The sound is at 7,875 Hz, which is half the horizontal sweep frequency. In some sets, the door of the high-voltage cage is resonant at this frequency. This can be corrected by placing a piece of tape around the edge of the door and tightening the screws around the cage area.

Symptom: Critical vertical hold, accompanied by some high-voltage arcing in the picture.

Cure: Make sure that the CRT's Aquadag coating makes contact with the grounding wire finger from the CRT harness. There should be two spring contactors.

Symptom: A 60-Hz sync buzz is audible when the volume is lowered.

Cure: Ground the low side of the volume control to the control mounting bracket.

Symptom: Beat patterns on the screen when viewing channel 3 with an indoor dipole antenna.

Cure: Add a 100-ohm, ½-watt resistor (R216) between the anode of D202 and the end of L208 as shown (Continued on page 72)

INSTALL TOMORROW'S IGNITION SYSTEM ON YOUR CAR TODAY

The Judson Electronic Magneto

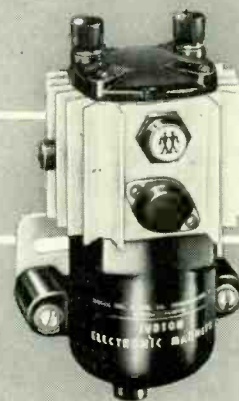

WHY DRIVE A LATE MODEL CAR WITH A 1910 IGNITION SYSTEM?

WHAT IT DOES: eliminates frequent tune-ups • triples plug and point life • provides better and smoother performance • gives you positive ignition for turnpike driving • develops all the power your engine can produce • reduces fuel consumption and pays for itself • you need one on your car now.

Do not confuse the Judson Electronic Magneto with ordinary transistorized ignition systems. Guaranteed to outperform and outlast any electronic ignition system on the market. Sensibly priced at only \$49.50. Can be installed within twenty minutes.

Write today for Literature.

JUDSON

RESEARCH AND MFG. CO.
CONSHOHOCKEN, PENNA.



LOOK! A NEW ELECTRONICS SLIDE RULE

with complete instruction program

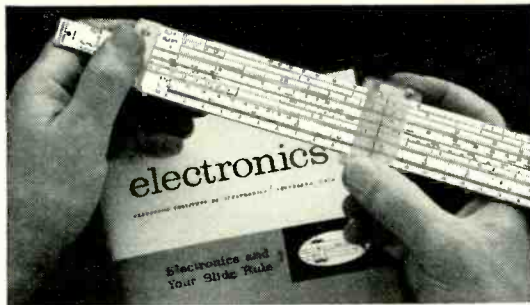

Here's a great *new* way to solve electronic problems accurately, easily . . . a useful tool for technicians, engineers, students, radio-TV servicemen and hobbyists. The Cleveland Institute Electronics Slide Rule is the only rule designed *specifically* for the exacting requirements of electronics computation. It comes complete with an illustrated Instruction Course. You get four AUTO-PROGRAMMED lessons . . . each with a short quiz you can send in for grading and consultation by CIE's expert instructors.

See for yourself. Learn how to whip through

all kinds of reactance, resonance, inductance, AC and DC circuitry problems in seconds . . . become a whiz at conventional computations too!

This all-metal 10" rule is made to our rigid specs by Pickett, Inc. . . . comes complete with top grain leather carrying case and Instruction Course. A \$50 value for less than \$25. Send coupon for FREE illustrated booklet and FREE heavy vinyl Pocket Electronics Data Guide. Cleveland Institute of Electronics, 1776 E. 17th St., Dept. RE-163, Cleveland, Ohio 44114.

TECHNOTES

(continued from page 71)

in the diagram. (Note well that capacitor C219 connects to the anode of D202 and *not* to the right-hand end

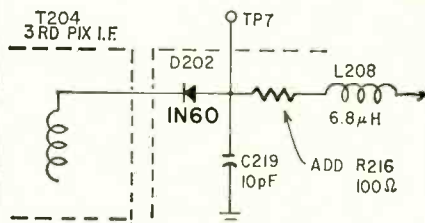

of R216 as in the schematic supplied with late versions of CTC-400.)—*Olympic Service Bulletin*

CTC17X HIGH-VOLTAGE TROUBLE

This color chassis had no raster and no high voltage. After a few minutes the 6JE6 horizontal output tube got red-hot and then the circuit breaker cut out. The horizontal output, damper and horizontal oscillator tubes were replaced but still the circuit breaker wouldn't hold.

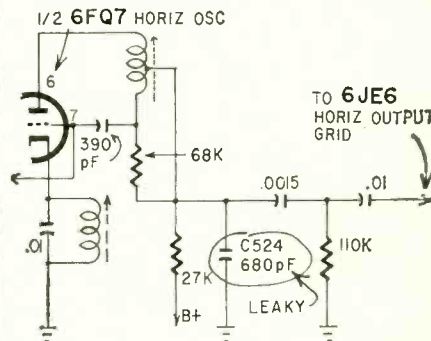

The chassis was pulled and a voltage check on the grid of the 6JE6 showed only -10 volts. To check the drive voltage, we removed the plate cap of the 6JE6 and watched for the grid voltage to shoot up. But it climbed only a few volts. The trouble had to be in the horizontal oscillator circuit.

There was only +47 volts on the plate (pin 6) of the horizontal oscillator. The reading should have been +268 volts. A leakage check showed that C524, a 680-pF capacitor, had a 31,000-ohm leakage. The capacitor was replaced and high voltage and raster were restored once again.—*David Mark* **R-E**

COLOR TV SELLS

Color TV sales rose to an all-time high in 1968. Almost 25% of all TV sets sold were color sets. **R-E**

GET BOTH FREE!

ELECTRONICS SLIDE RULE

Send coupon today

Cleveland Institute of Electronics

1776 E. 17th St., Dept. RE-163, Cleveland, Ohio 44114

Send FREE Electronics Slide Rule Booklet. Special Bonus: Mail promptly and get FREE Pocket Electronics Data Guide too!

NAME _____ (Please Print)

ADDRESS _____ COUNTY _____

CITY _____ STATE _____ ZIP _____

A leader in Electronics Training... since 1934

Circle No. 33 on reader service card

COMPLETE TUNER OVERHAUL

995

ALL LABOR AND PARTS
(EXCEPT TUBES & TRANSISTORS)*



COLOR TUNERS

GUARANTEED COLOR ALIGNMENT — NO ADDITIONAL CHARGE

Simply send us the defective tuner complete; include tubes, shield cover and any damaged parts with model number and complaint. Your tuner will be expertly overhauled and returned promptly, performance restored, aligned to original standards and warranted for 90 days.

UV combination tuner must be single chassis type; dismantle tandem UHF and VHF tuners and send in the defective unit only.

Exact Replacements are available for tuners unfit for overhaul. As low as \$12.95 exchange. (Replacements are new or rebuilt.)

And remember—for over a decade Castle has been the leader in this specialized field . . . your assurance of the best in TV tuner overhauling.

CASTLE TV TUNER SERVICE, INC.

5715 N. Western Ave., Chicago 45, Illinois
41-96 Vernon Blvd., Long Island City 1, N. Y.

For service in Canada write to Chicago or use reader service card in this magazine.

*Major parts are charged extra in Canada.

NEW!

A BETTER WAY TO REPLACE SOLDERED COMPONENTS

LENGTH 8" WEIGHT 3½ OZ.



ENDECO

Pencil Desoldering Iron MODEL 300

Now—remove miniature soldered components in seconds—without damage

Hollow tip fits over connection; vacuums all solder for easy removal of component. Leaves terminals and mounting holes clean. Then, with 360° contact, it resolders faster, better than regular irons. Handles miniature and standard components in PC boards and conventional wiring. Self-cleaning. All parts replaceable. 40 watts, 120-v. Standard tip supplied, 6 other tip sizes. Pays for itself. \$10.95 net East of the Rockies.

Larger model available. See your distributor or write:

ENTERPRISE DEVELOPMENT CORPORATION
5149 E. 65th · Indianapolis, Ind. 46220

Service Clinic

By **JACK DARR**
SERVICE EDITOR

This column is for your service problems—TV, radio, audio or general and industrial electronics. We answer all questions individually by mail, free of charge, and the more interesting ones will be printed here.

If you're really stuck, write us. We'll do our best to help you. Don't forget to enclose a stamped, self-addressed envelope. Write: Service Editor, Radio-Electronics, 200 Park Ave. South, New York 10003.

Slow-burn transistors

I have an Airline GHJ 2346A stereo amplifier with an odd problem. After running for about 30 minutes, the output transistors begin to heat up. They get very hot—then, if you don't turn the set off, out they go. At the same time, the 1-ohm 2-watt resistor in the power supply gets very hot.

I see a 150-ohm, 7-watt resistor connected from the -17-volt tap to ground; I've seen this on several other sets of the same model. It's not on the schematic, though. What is it for?—H.G., Fredericksburg, Va.

Well, "what" is easy in this case. Your output transistors are undergoing a "thermal runaway." The junction(s) are carrying too much current and getting too hot. This makes them increase their current drain and get even hotter, until finally the junction is destroyed. This is a reasonably common trouble.

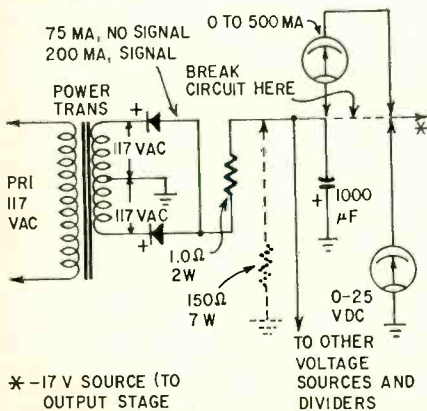

* -17 V SOURCE (TO OUTPUT STAGE COLLECTOR ONLY)

The major cause is incorrect bias or insufficient heat-sinking (or both). You will have to run "elimination"

tests to find out what's going on.

The power supply for the output circuit is shown. Break the circuit and insert an 0-500 dc milliammeter, at the load end of the 1-ohm resistor. The normal current here is 75 mA, no signal, and about 200 mA with signal. Turn the set on, and check for these values. It would also be a good idea to monitor the voltage output at the same point, although the current will tell you when there is danger. Watch out for an increase in the supply voltage.

If the current starts to go higher than the rated maximum of 200 mA, cut the amplifier off. Here are a cou-

ple of things you might try: add more area to the heat sinks on these transistors, and check the heat sinks to be sure that there is silicone grease between them and the transistor cases for best heat transfer.

You might get better results with one of the small ventilating fans, set to blow directly on the heat sinks. Actually, this sounds very much like "not enough heat sink area."

The 150-ohm shunt resistor across the -17-volt point must be a modification, added to help stabilize this voltage. It isn't shown in the Sams diagram either.

FREE!



BRAND NEW EDITION
1969 Catalog 690

Serving The Public
Since 1920

Featuring Everything in Electronics for
• HOME • INDUSTRY • LABORATORY
from the "World's Hi-Fi & Electronics Center"



Over 500 Pages

- Electronic Parts... Tubes... Tools
- Citizens Band Equipment
- PA Equipment
- Test Instruments
- Closed Circuit TV
- Stereo Hi-Fi Systems & Components
- Tape Recorders
- Amateur Radio Equipment
- Radio & TV Sets & Accessories
- Cameras & Supplies
- Books

LAFAYETTE RADIO ELECTRONICS

Dept. 17049

SYOSSET, L.I., N.Y. 11791

Send For **FREE**
1969 Catalog
TODAY!

Send **FREE** 1969 Catalog 690 Dept. 17049

Name.....

Address.....

City.....

State.....

Zip.....

NORTRONICS

REPLACEMENT TAPE HEADS
IMPROVE THE PERFORMANCE
OF ANY TAPE RECORDER!

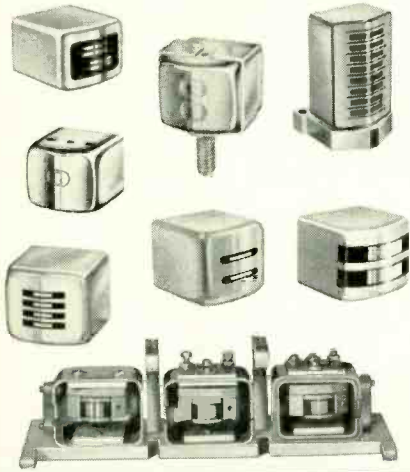

**WORLD'S LARGEST
HEAD SELECTION FOR
PROFESSIONAL EQUIPMENT**

AMPEX • MAGNECORD • SCULLY
CONCERTONE • RCA • CROWN

AS WELL AS 1800
POPULAR PRICED RECORDERS
DOMESTIC AND IMPORTED



MONO OR STEREO
REEL-TO-REEL OR
CASSETTE AND CARTRIDGE
TYPES

ANY TRACK STYLE

Full, Half, Quarter, or Eighth

ANY FUNCTION

Record, Playback, Erase, R/P, and R/P/E

Replace worn tape heads with the brand most often chosen by tape recorder manufacturers for use in original equipment. (Over 80% use Nortronics!) It's a quicker and easy way to better response, cleaner sound, optimum performance.

NORTRONICS Bulletin 7230A describes the complete line of Nortronics replacement heads, conversion and mounting kits, and accessories. Write for your free copy.



8101 Tenth Avenue North
Minneapolis, Minnesota 55427
Phone: (612) 545-0401

SERVICE CLINIC

(continued from page 73)

FM TVI on ch. 6.

I live close to an FM station. This didn't bother me in the past, but in the last 3 months they've been chewing up both sound and picture on Ch. 6! I called the station and they said they couldn't do anything about it. Should I contact the FCC? Is there a trap which will eliminate this kind of interference? C. V., Penna.

Before going to the FCC, it would be a good idea to check with several of your neighbors, and see if their sets are acting the same way. If so, and if this interference has been seen only in the last 3 months, then there is a chance that the FM station is getting 'out-of-band' or radiating some kind of harmonics. Find out if the station has increased power, etc., or made any change in its transmitter at about that time.

In a lot of cases, 'TVI' is not actually caused by a nearby transmitter, but by intermodulation effects in the front end of the TV receiver itself! The strong RF signals that are unavoidably picked up on your antenna may mix with the TV signals, and create 'beats' that in turn make interference. This, of course, can happen even if the FM station or amateur transmitter is operating within the FCC tolerances. In this case, the only thing to do is cut down on the amplitude of this interfering signal.

Try RCA's favorite trap-circuit. This is simply a 4.5 inch length of 300-ohm twin-lead, with one end shorted, and a 2-15 pf ceramic trimmer capacitor tied across the other end. Tape this tightly to your lead-in cable, preferably as near to the TV tuner as possible. Now, tune to Ch. 6, and adjust the trimmer capacitor for minimum interference. Many TV sets, such as RCA, have 'FM trap circuits' built into the balun coil assembly on the tuner. You might make up an FM trap and hook it into the antenna lead; any good service technician can fix up one of them from stock parts and tune it up.

If all else fails, and you find that all other sets in the area are getting the same interference, then write to the FCC, Washington, D. C., Field Engineering and Monitoring Division, and they'll investigate as soon as they can.

P-P Voltage off on VTVM.

I get odd readings on my vtvm when I try to read peak-to-peak voltages in the agc keyer circuit. Reads different voltages at the same point when I

change meter ranges. Seems to read right on 60-Hz voltages, though.—A. A., Cumberland, Md.

Many ac voltmeters won't read exactly right on very narrow pulse voltages, which this is, in the ac keyer circuit. You're trying to read about a 4-5-usec pulse! If the meter input time-constant isn't correct, the capacitor won't have time to charge up on such short pulses, and the meter will read low. (All p-p meters like this read the voltage developed by charging a capacitor.)

Many meters are calibrated for 60-Hz cycle sine-wave ac, and will read correctly with that frequency and waveform; however, when we get away from a pure sine wave, we can get into troubles. A scope is still best for this.

Testing low-voltage electrolytics

I wish I had a good reliable test for low-voltage electrolytic capacitors in transistorized equipment.—L. S., Sandy, Utah

So do I. In the meantime, try this one. The best test for any part is "Does it work?". That is, does it do what it's supposed to.

There are two main uses for electrolytics in this kind of stuff—coupling and bypassing (or filtering). To check each, see if the capacitor is doing what it should. For couplers, feed a test signal into the circuit, then check its level at the input and output of the capacitor. Should be the same. If not, it's bad.

For bypasses, use the same test. For instance, in a typical af transistor circuit, I found the same signal level on the emitter and the collector. Obviously, the big emitter bypass should have killed all signal on the emitter. When I saw that high signal level there, I knew that the emitter bypass was open.

Filters, too: if you find more than about 1 volt of anything (signals, ripple, hash, etc.) on one of the supply lines where a big electrolytic capacitor should filter it out, look out. That capacitor is either open or very low in capacitance.

FM station covers whole band

I've got a strong FM station near the house; it covers the whole band! Is it blocking out the other stations by capture effect, or what? If I turn the set off, and then on again, I can hear other stations before they're drowned out. How can I eliminate this? —R. S. W., San Francisco, Calif.

This effect isn't confined to FM; you can get it by being too near a high-powered AM station. There's only

Dyna-flex*

the only practical probe for testing transistors in circuits.

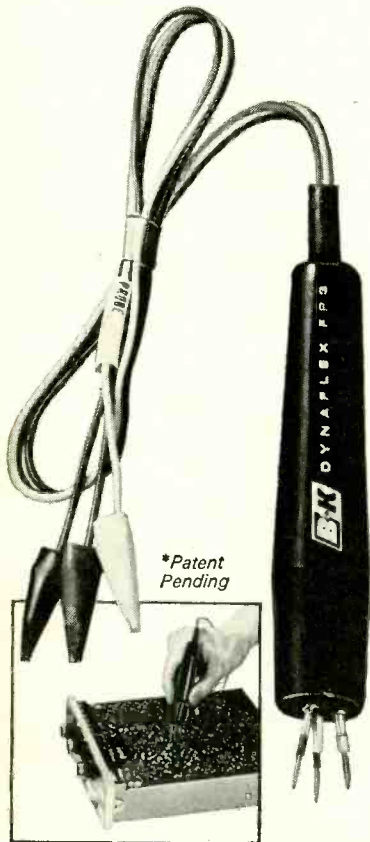

*Patent Pending

Throw away your alligator clips! Dyna-flex, the world's first and only 3-point probe, makes instant test connections to transistors in printed boards. Easy to use, the Dyna-flex probes are spring-mounted on ball joints. Allow you to adjust to any spacing 1/32" to 5/8", using only one hand. Dyna-flex eliminates costly unsoldering; can be used to make temporary component substitutions on printed wiring boards. Each point is color-coded for fast, easy identification. Dyna-flex—another engineering breakthrough from B&K.

Model FP-3, \$12.95 user net



B&K Division of Dynascan Corporation
1801 W. Belle Plaine Avenue/Chicago, Illinois 60613

Where Electronic Innovation Is A Way Of Life

Circle 38 on reader service card

APRIL 1969

one answer: reduce the signal strength of the offending station.

Try this trap circuit: Cut a piece of 300-ohm twin-lead about 4½ inches long, short one end, and connect a 3–15 pF ceramic trimmer capacitor across the other. (This is RCA's famous "TVI trap.") Tape this tightly to your lead-in as near to the tuner as possible. Tune the trimmer for minimum signal from the local station.

Sweep generator output low?

My sweep generator works very well on i.f. alignment, but I can't get enough scope pattern height on tuner alignment, especially on the high channels. What can I do about this?—E. N., Winnipeg, Man.

This is pretty much "normal." Most sweep generators use fundamentals on i.f.'s and even the low TV channels, but go to harmonics for the very high bands. When you double the frequency of an rf signal, you also halve the amplitude! Since we have a good-sized loss in our pickup probes, too, this often leaves us with not a heck of a lot of "curve" on alignment.

You might do two things: One, go on through the first i.f. stage and hook the scope to the second i.f. grid. Shunt the tuned circuit in the first i.f. plate with about a 10,000-ohm resistor, to flatten it and keep it from af-

fecting the curve. Makes the first stage act as a "preamp" for the scope.

The other thing you might do—add a wide-band rf amplifier between the sweep generator and tuner input. A good all-band TV antenna booster might work very well for this, since many of these have overall gains of up to 20–25 dB. Some boosters have 75-ohm coax input and output, or 75 in and 300 out. **R-E**

SOLUTION TO R-E PUZZLER

(page 40)

- | | |
|---------------|------------------|
| 1. printed | 9. Cesium |
| 2. scrambler | 10. Actuator |
| 3. adapter | 11. Inverter |
| 4. audion | 12. Brown |
| 5. moire | 13. Anodizing |
| 6. roentgen | 14. Alnico |
| 7. ripples | 15. Circuit |
| 8. electrodes | 16. Arcs |
| | 17. Atmospherics |

A perfect score is 102. Subtract 6 points for each part you may not have answered correctly and find your rating below.

- 54–60 Sub.
- 66–72 Norm.
- 78–84 Super.
- 90–96 Ultra.
- 102 PERFECT!

Build this pipelike Schober Recital Organ for only \$1725!*

You couldn't touch an organ like this in a store for less than \$4,000—and there never has been an electronic instrument with this vast variety of genuine pipe-organ voices that you can add to and change any time you like! All four families of formal pipe tones are present in variety to delight players of classic and religious music. Yet you can change the entire organ for popular and theatrical sounds, or plug in special voices for baroque, romantic, or modern repertoires. If you've dreamed of the sound of a large pipe organ in your own home, if you're looking for an organ for your church, you'll be more thrilled and happy with a Schober Recital Organ than you could possibly imagine—kit or no kit.

You can learn to play it—and a full-size, full-facility instrument is easier to learn on than any cut-down "home" model. And you can build it, from Schober Kits, world famous for ease of assembly without the slightest knowledge of electronics or music, for design and parts quality from the ground up, and—above all—for the highest praise from musicians everywhere.

Send right now for the full-color Schober catalog, containing specifications of all five Schober Organ models, beginning at \$599.50. No charge, no obligation. If you like music, you owe yourself a Schober Organ!



*Includes finished walnut console. (Only \$1361 if you build your own console.) Amplifier, speaker system, optional accessories extra.

Circle 39 on reader service card

The Schober Organ Corp., Dept. RE-65
43 West 61st Street, New York, N.Y. 10023

- Please send me Schober Organ Catalog and free 7-inch "sample" record.
- Enclosed please find \$1.00 for 12-inch L.P. record of Schober Organ music.

NAME _____

ADDRESS _____

CITY _____ STATE _____ ZIP _____

RADIO-ELECTRONICS READER SERVICE

Here's how you can get manufacturers' literature fast:

1. Tear out the post card on the facing page. Clearly print or type your name and address. **Include zip code!**
2. Circle the number on the card that corresponds to the number appearing at the bottom of the **New Products, New Literature or Equipment Report** in which you are interested.
For literature on products advertised in this issue, circle the number on the card that corresponds to the number appearing at the bottom of the advertisement in which you are interested. Use the convenient index below to locate quickly a particular advertisement.
3. Mail the card to us (no postage required in U.S.A.)

ACCURATE INSTRUMENT COMPANY, INC. (p. 61)	Circle 23
ALLIED RADIO CORPORATION (p. 90)	Circle 115
ARCTURUS (p. 96)	Circle 136
BELL P/A PRODUCTS CORPORATION (p. 14)	Circle 15
B & K (Division of Dynascan Corporation) (p. 75)	Circle 38
BROOKS RADIO AND TV CORPORATION (p. 82, 83)	Circle 107
BSR USA LIMITED (p. 68)	Circle 26
BURSTEIN-APPLEBEE COMPANY (p. 70)	Circle 30
CARINGELLA ELECTRONICS, INC. (p. 91)	Circle 117
CASTLE TV TUNER SERVICE (p. 72)	Circle 34
CLEVELAND INSTITUTE OF ELECTRONICS (p. 62-65)	Circle 24
(Slide Rule) (p. 72)	Circle 33
CORNELL ELECTRONICS COMPANY (p. 98)	Circle 139
DELTA PRODUCTS, INC. (p. 15, 66, 95)	Circle 16
ELECTRONIC CHEMICAL CORPORATION (p. 85)	Circle 111
EDMUND SCIENTIFIC COMPANY (p. 97)	Circle 138
ENTERPRISE DEVELOPMENT CORPORATION (p. 72)	Circle 35
ESSEX INTERNATIONAL INC.—CONTROLS DIVISION, STANCORE INC. (p. 68)	Circle 27
FAIR RADIO SALES (p. 94)	Circle 124

GRANTHAM SCHOOL OF ELECTRONICS (p. 1)	Circle 9
HEALD ENGINEERING COLLEGE (p. 90)	Circle 113
HEATH COMPANY (p. 86-89)	Circle 112
INTERNATIONAL CRYSTAL MANUFACTURING COMPANY (p. 100)	Circle 148
INTERNATIONAL TEXTBOOK COMPANY (p. 7)	Circle 11
JUDSON RESEARCH AND MANUFACTURING COMPANY (p. 71)	Circle 32
KENWOOD (p. 27)	Circle 21
LAFAYETTE RADIO ELECTRONICS (p. 73)	Circle 36
MALLORY DISTRIBUTOR PRODUCTS COMPANY (Distributor Sales Division) (p. 5)	Circle 10
MICROFLAME, INC. (p. 70)	Circle 31
MULTICORE SALES CORPORATION (p. 92)	Circle 120
NORTRONICS (p. 74)	Circle 37
OLSON ELECTRONICS, INC. (p. 91)	Circle 116
OXFORD TRANSDUCER CORPORATION (p. 12)	Circle 13
PENWOOD NUMECHRON COMPANY (p. 85)	Circle 110
PIONEER ELECTRONICS (Cover II)	Circle 8
POLY PAKS (p. 99)	Circle 140
RCA ELECTRONIC COMPONENTS (Test Equipment) (p. 13)	Circle 14
RCA PARTS AND ACCESSORIES (p. 84)	Circle 108
RYE INDUSTRIES, INC. (p. 92)	Circle 119
SAMS AND COMPANY, INC., HOWARD W. (p. 22)	Circle 20
SCHOBER ORGAN (p. 75)	Circle 39
SENCORE (p. 16)	Circle 17
SHURE BROS. (p. 69)	Circle 28
SIDCO MANUFACTURING COMPANY (p. 85)	Circle 109
SOLID STATE SALES (p. 97)	Circle 137
SONAR RADIO CORPORATION (p. 91)	Circle 118
SONY CORPORATION OF AMERICA (p. 80, 81)	Circle 106
SYLVANIA (Subsidiary of General Telephone & Electronics) (p. 67)	Circle 25
TV TECH AIDS (p. 90)	Circle 114
XCELITE, INC. (p. 17)	Circle 18

NEW PRODUCTS

More information on new products is available from the manufacturers of items identified by a Reader Service number. Use the Reader Service Card at the left and circle the numbers of the new products on which you would like further information. Detach and mail the postage-paid card.

COMBO BASS AMPLIFIER, Model TA-38, solid-state, delivers 120 watts of EIA music power with a peak power rating of 240 watts. Two 12" speakers designed to reproduce complete frequency range of bass guitars, organs and other bass



instruments at high sound levels with low distortion. Unit has two bass inputs, volume, bass and treble controls and Depth and Presence switches on the front panel. \$225. Black vinyl cover, TAA-38, available at \$11.95.—Heath Co.
Circle 46 on reader service card

STEREO HEADPHONE, SE-20. Matching impedance: 4-16 ohms, earpiece element impedance: 8 ohms. Maximum



input: 0.5 watt per earpiece. Frequency response: 20-18,000 Hz. Rigid molded vinyl earcups are slightly larger than average to ensure optimum isolation of

sound. Acoustically absorbent, soft "kid" ear cushions supply maximum listening comfort. \$19.95 including case, 8-ft cord and a 3-conductor plug.—Pioneer Electronics USA Corp.

Circle 47 on reader service card

DIGITAL SET-POINT CONTROLLER, Model 1050, operates from either 115 V or 220 V power source, 47 to 400 Hz, with Digital Measuring System, DMS 3200P, or other devices having 10-line decimal outputs; determines operation of any peripheral function at preset measurement values. As a 3-digit controller, it has 1 MHz response. As a 6-digit con-



troller (2 units in tandem), 100 kHz response. Indicator lamps on front panel show measurements falling within or outside "accept" band. Upper and lower set-points provide absolute values at which external control circuitry is activated. \$230.—The Hickok Electrical Instrument Co.

Circle 48 on reader service card

MATCHING TRANSFORMER, Model MT60, indoor, 82 channels. Matches 75-ohm coaxial cable to 300-ohm TV and FM inputs. Passes all uhf and vhf TV

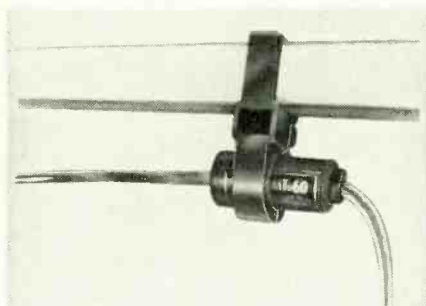

channels plus all FM stations. \$2.95. Outdoor version: Model MT61, completely weatherproof. \$3.50.—JFD Electronics Co.

Circle 49 on reader service card

AUTO TURNTABLE, Model 929, allows fully automatic, semi-automatic or manual operation of stereo and monophonic records. Four speeds; 16%, 33%,

45 and 78 rpm. Pickup arm may be lifted off a record in play and then lowered into the same groove. Resiliently mounted 4-pole motor reduces wow to



less than 0.12% rms and flutter to less than 0.05% rms at 33% rpm. \$69.96 with 3 choices of stereo cartridge. Wood base and dust cover optional.—Allied Radio Corp.

Circle 50 on reader service card

DYNAMIC MICROPHONE, No. 38-175, unidirectional, is equipped with wire mesh windscreen to eliminate noise caused by wind and static pressure. Fre-



quency response, 100 Hz-12,000 Hz; dual impedance, 600-50K ohms; sensitivity, -73dB to 54 dB. Comes with 20' cable and standard phone plug and swivel mike stand connector. \$13.95.—AMD Electronics

Circle 51 on reader service card

2-WAY STEREO HEADSET, SE-50, has 3" cone-type transducer for bass and mid-range, and a miniature type



with Mylar diaphragm for treble. Stated frequency response: 20 Hz to 20 kHz. Audio power input: 0.5 watt max. each

The Missing



Circle 106 on reader service card

channel, 12' coil cord and a 3-conductor stereo plug. \$49.95.—Pioneer Electronics USA Corp.

Circle 52 on reader service card

BACKGROUND MUSIC DECODER, Model SCA-1, picks up "hidden" musical programs from many FM stations, 400 in USA. Works with any FM tuner or receiver, and provides commercial- and



talk-free background music. All solid-state circuitry including 2 IC's, 3 FET's and 3 transistors plus "mute" control for total silence during pauses between musical selections. \$64.50 wired, \$49.95 kit.

—S.C.A. Services Co.

Circle 53 on reader service card

PORTABLE TAPE RECORDER, Model 1055, solid-state, operates on ac or batteries. Records and plays 2-track mono at 3 $\frac{3}{4}$ and 1 $\frac{1}{2}$ ips. Speaker monitoring permits operator to listen to material be-

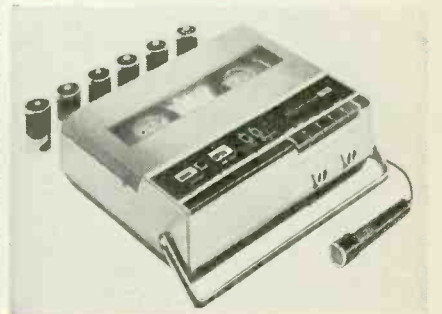

ing recorded. Inputs for mike and auxiliary; outputs for extension speaker and headphones. On/off mike, 6 D-batteries, ac cord, patch cord, 5" reel of tape and 5" takeup reel. \$69.95.—Allied Radio Corp.

Circle 54 on reader service card

ANTENNA-ROTOR SYSTEM, Model T-45 Tenna-Rotor can be operated by up to 5 controls located in different areas.

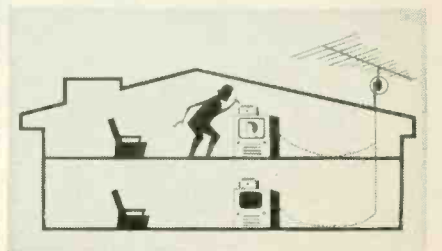

Shows antenna direction on all controls. 5-wire circuit unaffected by motor current, cable length or line-voltage varia-

Linkage



The evolution of a better turntable

The New Sony PS-1800 playback system has something missing. It also has several things not found in other turntables. And therein lies the story of its superior performance.

What's missing? Sony has done away with the mechanical linkages between arm and turntable required in the automatic shutoff systems of all other record playing instruments. To achieve this, Sony developed a completely new kind of solid state device, the SONY Magnetodiode (SMD). It replaces the troublesome mechanical linkages and eliminates any chance of drag in the tonearm's motion across the record.

What does the PS-1800 have that other turntables don't?

The convenience of automatic shutoff after record is played. A servo-controlled DC motor that always operates at pre-

cisely the correct speed. A DC motor that rotates at 300 rpm, one-sixth the speed of conventional AC motors, to reduce the intensity of motor-produced vibration.

What does this all mean to you? A turntable with a precisely balanced tonearm of low mass design that tracks records flawlessly. A turntable that is absolutely silent (total wow and flutter, only 0.08% rms and rumble 60 dB below the NAB reference level).

The new Sony PS-1800 playback system — turntable, tonearm, oil-finish walnut base, dust cover. Under \$200. Evolution? It's a revolution. Sony Corporation of America, 47-47 Van Dam Street, Long Island City, New York 11101.

**SONY® PS-1800
PLAYBACK SYSTEM**

tions. Weatherproof unit turns the largest color antennas. Finger-pressure control bar directs rotation through 360° at 1 rpm.—Alliance Mfg. Co.

Circle 55 on reader service card

VEHICLE ALARM SYSTEM senses electrical current flow from battery. Pulsates the horn and headlights of car as a warning signal if car is tampered with.



Shuts off and resets after 3-5 minutes. Five connections to hook up unit. Complete with lock switch, wire, terminals, miscellaneous hardware and instructions. \$28.50.—Astro-Dynamics Electronics

Circle 56 on reader service card

FILL N' FILE SYSTEM is a reusable see-through/plastic dome secured to a heavy-duty index card with a sliding card insert. Pull out sliding card insert

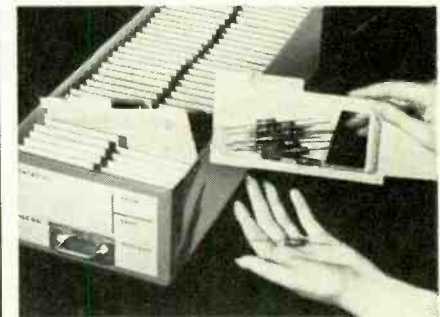

until opening matches opening in the file card and a part can be placed into the unit. Part is inventoried with the file card. Wide range of sizes.—Apsco Packaging Co.

Circle 57 on reader service card

CB 2-WAY RADIO has built-in police and fire monitor receiver. *Telsat 150*, provides mobile two-way communications on 23 crystal-controlled CB chan-



nels as well as receiving vhf FM 150-174-MHz) police and fire frequencies. Includes power supply for 12 Vdc, negative or positive ground. Operates on 117

Vac with optional power supply. Sensitivity 0.7 μ V on CB, less than 1 μ V on vhf FM. Input power: 5 watts; modulation: 100%. \$199.95.—Lafayette Radio Electronics Corp.

Circle 58 on reader service card

WIRE/RIBBON CUTTER, *Square-Kut*, cuts absolutely flat on wire or tubing up to 0.0734" (13 gage) diam or on metal

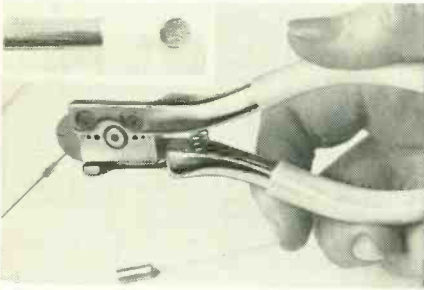

ribbon up to 0.025" thick and 0.125" wide. Shearing action eliminates distortion or burring.—Henes Mfg. Co.

Circle 59 on reader service card

SCREW-HOLDING SCREWDRIVER has vinyl tubing cover for protection for



electrical work. Useful for any type of electronics work where protection from

shock is essential. Dielectric strength at room temperatures is 20,000 volts.—Kedman Co.

Circle 60 on reader service card

STYLUS CLEANER consists of a lint-free treated pad. May be used on either



radial or elliptical styli. \$1.25 each, with instructions.—Elpa Marketing Industries Inc.

Circle 61 on reader service card

VHF/FM MONITOR RECEIVER, *Reporter*, operates on up to 6 crystal-controlled channels in 30-50-MHz or 152-174-MHz band. Dual-conversion solid-state superhet circuit with silicon mesa transistors in the rf, i.f. stages and oscillator circuit. For mobile applications, 12-volt electrical power source required.



At fixed locations, 110-115-volt ac power line.—Unimetries Inc.

Circle 62 on reader service card

AEROSOLS FOR ELECTRONICS, No. 2000, protects against rust and corrosion of critical circuit components. Waterproof



spray dries quickly, forms flexible film that seals treated area. Comes with spray nozzle attachment.—Sprayon Products Inc.

Circle 63 on reader service card

Shopping Power For Your Dollar

FREE \$1 BUY WITH EVERY 10 YOU ORDER Only applies to "\$1" Buys FREE GIFT WITH EVERY ORDER

- 100—ASST 1/4 WATT RESISTORS stand. choice ohmages, some in 5% \$1
- 100—ASST 1/2 WATT RESISTORS stand. choice ohmages, some in 5% \$1
- 70 — ASST 1 WATT RESISTORS stand. choice ohmages, some in 5% \$1
- 35 — ASST 2 WATT RESISTORS stand. choice ohmages, some in 5% \$1
- 50 — PRECISION RESISTORS asst. list-price \$50 less 98% \$1
- 20 — ASSORTED WIREWOUND RESISTORS, 5, 10, 20 watt \$1
- 4 — TOGGLE SWITCHES SPST, SPDT, DPST, DPTD \$1
- 10—ASSORTED SLIDE SWITCHES SPST, SPDT, DPST, etc. \$1
- 100 — STRIPS ASSORTED SPAGHETTI handy sizes \$1
- METER SENTRY—SOLID STATE Protects meter movements up to 25 amps surge 99¢
- 15 — ASST. ROTARY SWITCHES all popular types \$20 value \$1
- 3 — TOP BRAND 35W4 TUBES \$1
- 7 — TV ELECTROLYTIC CONDENSERS desirable types \$1
- 3 — PRINTED CIRCUIT I.F. TRANS. 455 KC, 4 Lug—Input & Output \$1

- TRANSISTOR RADIO asst type good, bad, broken, as-is, potluck \$1.50
- TAPE RECORDER — assorted types good, bad, broken, as-is, potluck \$4
- 32' — TEST PROD WIRE deluxe quality, red or black \$1
- HEARING AID AMPLIFIER incl. 3 Tubes, Mike, etc. (as is) \$1
- 50 — #3AG FUSES 1/2 AMP popular type with pigtails \$1
- 10 — STANDARD TRANSISTORS NPN & PNP 2N404, 2N414, etc. \$1
- 10—ASSORTED DIODE CRYSTALS 1N34, 1N48, 1N60, 1N64, etc. \$1
- 6 — TRANSISTOR RADIO EARPIECES wired complete with plug \$1
- 1—SQ. YARD GRILLE CLOTH most popular brown & gold design \$2
- S20—SHURE M-7D DIAMOND NEEDLE exact replacement \$3
- \$15.00 TELEVISION PARTS "JACKPOT" best buy ever \$1
- 10 — SETS PHONO PLUGS & PIN JACKS RCA type \$1
- 10 — SURE-GRIP ALLIGATOR CLIPS 2" plated \$1
- 50 — ASSORTED PRINTED CIRCUIT SOCKETS best types \$1
- 10 SETS — DELUXE PLUGS & JACKS asst. for many purposes \$1
- 70—BRASS FARNESTOCK CLIPS popular type & size \$1

- SOLID STATE UHF CONVERTER Receives channels 14-83. Easy connection to your TV set \$16.95
- STANDARD TV TUNER 21mc— with schematic Popular type for many TV's \$5
- TV TUNERS asst. all new standard makes, including Tubes \$3
- WESTINGHOUSE STANDARD TUNER #47OV120H01 — (3GK5 — 6CG8 Tubes) \$4
- WESTINGHOUSE STANDARD TUNER #47OV071H02 — (6ER5 — 6CG8 Tubes) \$4
- SPECIAL TUBE BUY 3CB6, 3DT6, 4CS6, 12AU7, 12BH7. Each \$59¢
- 10 — ASST. RADIO & TV TUBES Every Tube a good number \$1
- 50 — ASSORTED TRANSISTORS big factory scoop—sold as-is \$1
- 20—ELECTROLYTIC CONDENSERS Fine asst.—too numerous to mention \$1
- 20 — ASST. VOLUME CONTROLS All desirable good types \$1
- 2 — POWER TRANSISTORS Replace 2N155, 2N176, 2N301, etc. \$1
- 2 — HYTRON POWER TRANSISTOR H.V. replaces DS501, 2N173, etc. \$1.29
- 10 — SPEAKER PLUG SETS deluxe type, 2 conductor \$1
- 3 1/2" — ROUND SPEAKER Special Buy \$59¢

- ### MARKET SCOOP COLUMN
- 12" OXFORD SPEAKER. Top Quality . . . Large Magnet \$4
 - 10" PHILCO SPEAKER Top Quality . . . Large Magnet \$2.69
 - 6"—ECONOMY SPEAKER Top quality 2.15 Mag. \$1.69
 - 5" UNIVERSAL TWEETER 1 Oz. . . Magnet \$1.29
 - UNIVERSAL 5 1/2" PM SPEAKER Alnico 5 magnet, quality tone \$1
 - UNIVERSAL 4" PM SPEAKER Alnico 5 magnet, quality tone 79¢
 - 2" x 6" SPEAKER Alnico 5 magnet, quality tone \$1
 - 25 — 3900-OHM-7w RESISTOR 10% Corning glass \$1
 - 20 — .47-600V CONDENSERS White Ceramic C.D.—American \$1
 - MOTOROLA PWR TRANSFORM 110v, Ct 150/150v, 6.3v \$1
 - 10 — TRANSFORMERS assorted Audio Outputs, Chokes, I. F., etc. \$1
 - AMPLIFIER 110v AC-DC, 5 Watt Wired — Phono, Comb. Intercom, etc. needs 3-12AX7, 2-5016-as is \$3
 - NYLON PRINTED CIRCUIT TOOL For Lead Bending & Dressing, will not scratch boards \$1
 - 50 — ASST. DISC CERAMIC CONDENSERS popular numbers \$1

IMMEDIATE DELIVERY . . . Scientific light packing for safe delivery at minimum cost. HANDY WAY TO ORDER: Pencil mark or write amounts wanted in each box, place letter F in box for Free \$1 BUY. Enclose with check or money order, add extra for shipping. Tear sheets will be returned as packing slips in your order, plus lists of new offers. MINIMUM ORDER \$3.00

Name

Address

Cost of goods

Shipping

estimated

TOTAL

Please specify refund on shipping overpayment desired: CHECK POSTAGE STAMPS MERCHANDISE (our choice) with advantage to customer

BROOKS RADIO & TV CORP., 487 Columbus Ave., New York, N. Y. 10024 212-874 5600 TELEPHONE

NEW LITERATURE

All booklets, catalogs, charts, data sheets and other literature listed here with a Reader's Service number are free for the asking. Turn to the Reader Service Card facing page 78 and circle the numbers of the items you want. Then detach and mail the card. No postage required!

HAND TOOLS. Plier No. 4916 designed for easy in-circuit installation and removal of 10- and 14-lead IC flat-pack units. *Tran-Semi*, a multipurpose tool for handling transistor and semiconductor devices and flush-cutting leads of any currently available device from circuit. 96 pages.—**Techni-Tool Inc.**

Circle 76 on reader service card

PRINTED-CIRCUIT CONNECTION problems and suggestions, together with many engineering diagrams of simplified printed-circuit assemblies. Information and application ideas for single- and multiple-bead pin-type connections, more economic assembly costs and faster production are in *Catalog M400*, 20 pages.—**Mntex Products Co.**

Circle 77 on reader service card

SLIDE SWITCHES including the new *Phase II* "double wipe" are described in 4-page *Bulletin No. 178*. Also included is a newly designed slider with either 3- or 6-A ac ratings. Engineering drawings show mounting configurations and contact arrangements available with the new series.—**Switchcraft Inc.**

Circle 78 on reader service card

SPRINGRIP FASTENERS, various types and sizes, data on other shaft-retention fasteners, special C-ring washers, push-on and Plasti-rings are illustrated in a 8-page brochure, *Form AF-9*. Information on standard in-stock Springrips of internal tooth design plus the manufacturer's other retaining fasteners is provided.—**Fastex Div. Illinois Tool Works Inc.**

Circle 79 on reader service card

TOOLS FOR ELECTRONICS assembly and precision mechanics plus numerous items on tool kits, test and vacuum ultrasonic cleaner, lighting and optical devices are described with charts and photos in 66-page *Catalog No. 386*. Sections of useful tips along with specs and data on various tools are informative and helpful. Prices listed.—**Jensen Tools & Alloys**

Circle 80 on reader service card

DIGITAL SYSTEM PLUG-INS in the "DP" series for digital measuring system *DMS 3200* are capable of measuring nearly all basic electrical parameters and providing a full digital display of measurements. The entire line is detailed with specifications and photos in *Form 185-59*. Accessories for these models are also described.—**Hickok Electrical Instrument Co.**

Circle 81 on reader service card

1969 CATALOG, 32 pages, outlines with photographs and prices a large variety of design slide rules, data selectors and templates—kits etc. Easy guidance for designers, draftsmen and engineers.—**TAD Products Corp.**

Circle 82 on reader service card

ACCESSORIES, EQUIPMENT, HAND TOOLS for vacuum systems, optical inspection, soldering and welding, Ednalite systems, Wassco and microminute and other electronic assembling aids are illustrated with charts and diagrams in *Catalog No. 15*, 82 pages. Specs and price list included.—**Techni-Tool Inc.**

Circle 83 on reader service card

DIGITAL PANEL METERS. Model 7020, 3-digit, single-range, single-polarity, 3 readings/sec. Model 7030, 3-digit. Model 7040, 4-digit. The last two have the same characteristics—overrange, dual polarity, 6 readings/sec. Full specs and description on these units plus two panel remote readouts for these models are contained in a sheet titled "Panel Mount Digital Meters".—**Fairchild Instrumentation**

Circle 84 on reader service card

Write direct to the manufacturers for information on items listed below:

1969 IC SHORT-FORM CATALOG, 24 pages, includes reference data for op amps, voltage regulators, communication circuits, TTL 54/74 series, TTL MSI types, MOS memories, analog switches and logic elements.—**National Semiconductor Corp.** 2975 San Ysidro Way, Santa Clara, Calif. 95051.

ZENER DIODE HANDBOOK, 74 pages, illustrated with schematics, graphs and tables. Covers semiconductor theory and reverse-breakdown phenomena plus specific information on dynamic resistance, temperature-compensated Zeners, thermal consideration, ac and dc applications, audio and rf applications and circuit protection. Computer and instrumentation applications included. \$3 each.—Write to **International Rectifier Corp.**, 233 Kansas St., El Segundo, Calif. 90245

CANADIANS: Ordering is easy — we do the paperwork — try a small order

Integrated Circuits
At Prices You Can Afford

Motorola HepKit Includes **ALL FIVE JUST \$3.95**

- One J-K Flip Flop
- One Dual Buffer
- One 4-Input Gate
- Two Dual 2-Input Gates

Also Tips On Using I.C.s. Including an Integrated Circuit Cross Reference Guide & 8 I.C. Project Circuits

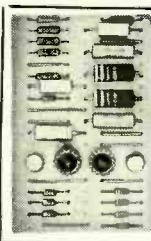

IBM COMPUTER SECTIONS
8 assorted Units we sell for \$1 are loaded with over 150 valuable parts.
Incl. — Transistors, Condensers, Resistors, Heat Sinks, Diodes, Etc.
8 for \$1
100 for \$10

SHANNON MYLAR RECORDING TAPE	
2 1/2" — 225'	\$.15
3" — 225'	.17
3" — 300'	.24
3 1/4" — 600'	.49
5" — 600'	.52
5" — 900'	.67
5" — 1200'	.86
5" — 1800'	1.29
7" — 1200'	.69
7" — 1800'	.99
7" — 2400'	\$1.59
7" — 3600'	2.78
CASSETTE 60 minutes	.89
CASSETTE 90 minutes	1.54
CASSETTE 120 minutes	1.97
2 1/2" TAPE REEL	.04
3" TAPE REEL	.05
3 1/4" TAPE REEL	.06
5" TAPE REEL	.12
7" TAPE REEL	.14

RCA 110° FLYBACK TRANSFORMER

We scooped the Market Latest type — standard for all 110° TV's

RCA's design of large Coil produces 14KV — assuring adequate width Inel Schematic Diagram application for any TV

List price \$13.90

Your price **\$3**
10% off in lots of 3

- 110° TV DEFLECTION YOKE for all type TV's incl schematic **\$3**
- "COMBINATION SPECIAL" RCA 110° FLYBACK plus 110° DEFLECTION YOKE **\$5**
- 90° FLYBACK TRANSFORMER for all type TV's incl schematic **\$2**
- 90° TV DEFLECTION YOKE for all type TV's incl schematic **\$2**
- 70° FLYBACK TRANSFORMER for all type TV's incl schematic **\$2**
- 70° TV DEFLECTION YOKE for all type TV's incl schematic **\$2**
- 2 — TV CIRCUIT BREAKERS Rated 4.2 TO 5.0 AMPS, etc. **\$1.19**
- 70° COLOR YOKE For all round color CRT's **\$12.95**
- 90° COLOR YOKE For all Rectangular 19 to 25" Color CRT's **\$12.95**

- BONANZA "JACKPOT" not gold, not oil, but a wealth of Electronic Items—Money-Back-guarantee **\$5**
- 300 — ASSORTED HEX NUTS 2/56, 4/40, 5/40, 6/32, 8/32 **\$1**
- 250 — ASST. SOLDERING LUGS best types and sizes **\$1**
- 250 — ASST. WOOD SCREWS finest popular selection **\$1**
- 250 — ASST. SELF TAPPING SCREWS #8, #8, etc. **\$1**
- 150 — ASST. 6/32 SCREWS and 150 6/32 HEX NUTS **\$1**
- 150 — ASST. 8/32 SCREWS and 150—8/32 HEX NUTS **\$1**
- 150 — ASST. 2/56 SCREWS and 150—2/56 HEX NUTS **\$1**
- 150 — ASST. 4/40 SCREWS and 150—4/40 HEX NUTS **\$1**
- 150 — ASST. 5/40 SCREWS and 150—5/40 HEX NUTS **\$1**
- 500 — ASSORTED RIVETS most useful selected sizes **\$1**
- 500 — ASSORTED WASHERS most useful selected sizes **\$1**
- 100 — ASST. RUBBER BUMPERS for cabinet bottoms & other uses **\$1**
- 100—ASSORTED RUBBER GROM-METS best sizes **\$1**

- RECORDING TAPE SPLICER **\$1.49** handy, accurate, compact
- 20 — ASSORTED TV COILS I.F. video, sound, ratio, etc. **\$1**
- 100' — TV TWIN LEAD-IN WIRE 300 ohm, deluxe heavy duty, clear **\$2**
- UNIVERSAL TV ANTENNA Back of set mounting 5 section rods **\$1.98**
- 3 WAY UHF—VHF—FM SPLIT-TER Two Sets of terminals make hookup a cinch **\$1.98**
- 2—G.E. PIECES OF EQUIPMENT stacked with over 200 useful parts **\$1**
- 50 — ASSORTED MYLAR CONDENSERS popular selected types **\$1**
- 3 — TOP BRAND SILICON RECTIFIERS 1 amp, 1000 PIV **\$1**
- 20 — ASST. PILOT LIGHTS #44, 46, 47, 51, etc. **\$1**
- 50 — ASSORTED #3AG FUSES popular ampere ratings **\$1**
- 4 — 50' HANKS HOOK-UP WIRE assorted colors **\$1**
- 100' — SPOOL SPEAKER WIRE 2 cond. mini zip, clear, 101 uses **\$1**
- 5 — I.F. COIL TRANSFORMERS 456-kc for Transistor Radios **\$1**
- 5 — AUDIO OUTPUT TRANSFORM Sub-min for Trans Radios **\$1**
- 5 — PNP TRANSISTORS general purpose, TO-5 case **\$1**
- 5 — NPN TRANSISTORS general purpose, TO-5 case **\$1**

- ALL AMERICAN TUBE KIT 12BA6, 12BE6, 12AV6, 50C5, 35W4—total list \$9.70 **\$2**
- UNIVERSAL MICROPHONE regular/remote/single & dual plug **\$2**
- CRYSTAL LAPEL MICROPHONE high impedance, 200-6000 cps **59¢**
- 25 — KNURLED RADIO KNOBS Hard to get... best selection **\$1**
- CHAPT ZU DI MITZIA "JACK POT" Double your money back if not completely satisfied **\$1**
- STEREO HEADPHONES Hi-Fi Quality... Complete with Stereo plug **\$5.95**
- 50 — TUBE CARTONS (colored) assorted sizes for Popular Tubes **\$1**
- 4 — TV ALIGNMENT TOOLS most useful assortment **\$1**
- 40 — ASSORTED TV KNOBS all standard types, \$20 value **\$1**
- 25 — VERT. LINEARITY KNOBS Long shank... best asst. **\$1**
- 50 — ASST. TERMINAL STRIPS all types, 1-lug to 6-lug **\$1**
- 25 — INSTRUMENT POINTER KNOBS selected popular types **\$1**
- 1 — LB SPOOL ROSIN-CORE SOLDER 40/60 top quality **\$1**
- TWEEZER: — Stainless steel — #5 Made in Switzerland—For fine work **\$1**
- 3—ELECTROLYTIC CONDENSERS most popular number 50/30—150v **\$1**
- 2 1/2" x 4" SPEAKER Special Buy **69¢**
- 5 — 6' LINE CORDS #18 Stranded Copper Wire **\$1**

Circle 107 on reader service card

The call-back killers...

Genuine RCA replacement parts.

They're famous for silencing customer complaints and wiping out costly call-backs.

That's because they're specially designed and fabricated . . . every electronic value, every material, every mechanical dimension . . . for particular applications in specific RCA home instruments.

In effect, they're original parts. They restore original performance and original customer satisfaction.

You can spread that satisfaction around by using many of them for universal application, too. They're great for upgrading performance wherever you use them.

Call your RCA distributor. He'll set you up with a supply of the fastest moving ones today.

Parts and Accessories, Deptford, N.J.



125 WATT STEREO AMPLIFIER

(continued from page 44)

than 0.1 volt when set up in this fashion.

If power supply voltages are correct and the dc output voltage is nearly zero, apply a small audio signal to the input. Monitor the output signal with a scope or ac voltmeter while advancing the level control slowly. With no other output load, the output voltage should reach about 33 volts rms. If severe clipping on half of the signal swing is noticed, do not proceed further until the difficulty is corrected. Crossover distortion will be noticed, but this is a normal condition at this time.

Turn the amplifier off and insert a milliammeter set to its 100-mA range in series with the collector lead of Q6. Turn the input level controls all the way down and apply power to the amplifier. Slowly increase the potentiometer substituted for R11 until the meter reads 20mA. Turn the amplifier off, measure the pot resistance and insert the nearest 5% value to this resistance as R11. This resistor might need changing if transistor Q5, Q6, Q8, or Q9 are changed in the amplifier.

Repeat this procedure for the other channel. It is not necessary to set the current to exactly 20mA. After reconnecting the Q6 collector lead to the PC board, you are ready to test the amplifier with a load. Connect your resistive load (4 ohms) across the output terminals, apply power and monitor output voltage as the input level is increased. At only a few watts, severe clipping will be noticed since the power supply cannot deliver rated output with the lamp resistance in series with the line input.

If the amplifier operates correctly thus far, it is unlikely that higher power operation will disclose any problems. However, you may wish to test with higher wattage lamps in series with the ac input.

After all tests are completed, a perforated protective cover may be fabricated if needed. In the final installation, be sure the bottom of the chassis is at least 1/2-inch off the mounting surface. Allow at least 3/4-inch clearance above the heat sinks for heat dissipation.

If you plan to drive 25 volt line transformers install D8 and D9. The output network shown on the schematic should be added when electrostatic speakers are used with this stereo power amplifier. **R-E**

COMING NEXT MONTH

If you think this amplifier is a honey, just wait until you see the preamp the author has dreamed up. Watch May.

APRIL 1969

85

NOW AVAILABLE IN KIT FORM

DIRECT FROM THE MFR.

AT A GREATLY REDUCED PRICE!

NEW ELECTRIC EYE INVENTION FOR UTMOST PROTECTION



With crime increasing daily, this low-cost Electric Eye Alarm System makes Headline News! Every apt. dweller, homeowner, stores, Professional offices, garages etc. should be vitally interested in the safety and security offered by this precision Unit.

Provides burglar protection across any area where installed. Alarm sounds instantly when beam is broken by any object. PLEASE NOTE: dense smoke will also set off alarm. Simply plug into any electric outlet. Adjust and use.



Direct from Mfr. only

\$1195
PPD.

FEATURES:

- Solid State Circuitry
- Remote Security Signal Light Connection
- Remote High Power Alarm Connection
- Burnout Proof Circuit
- Automatic Alarm Shut-Off & Reset
- Break Resistant Cabinet

COMPLETE
Simple Instructions

FACTORY BUILT—Completely wired at only \$19.95 Postpaid

SIDCO MFG. CORP., 533 Atlantic Ave., Freeport, N. Y. 11520

Circle 109 on reader service card

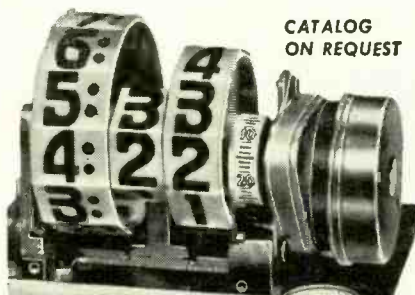

CATALOG ON REQUEST

12 **TYMETER** **24**
HOUR DIGITAL READ OUT HOUR
5/10 Digits 5/10 Digits

CLOCK MOVEMENTS

DIGITS RESETTABLE INDIVIDUALLY

Available in 50, 60 cy., all voltages, AC. UL approved motor, cord. One Year Guarantee.

#130...12-HOUR #131...24-HOUR

Tymeter #90
Direct Read-Out Interval
TIMER

by seconds,
minutes, 1/4 hr.,
1/2 hr., hour

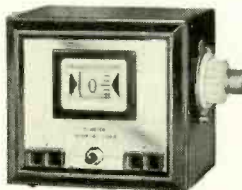

Made in U.S.A.

Complete Line: Delay, Interval
and Cycle Timers, Digital Computers

PENNWOOD NUMECHRON CO.
TYMETER ELECTRONICS

7249 FRANKSTOWN AVE., PITTSBURGH, PA. 15208

Circle 110 on reader service card

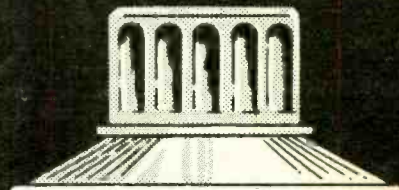

More and More Servicemen Say:
"We've tried cheaper
substitutes... now
WE'RE BACK TO
DEPENDABLE, RELIABLE

"NO NOISE"

World's No. 1 TRUSTED NAME BRAND

- VOLUME CONTROL & CONTACT RESTORER
- TUNER-TONIC with PERMA-FILM
- EC-44 FOR ELECTRICAL CONTACTS
- TAPE-RECO HEAD CLEANER
- FRIGID-AIR CIRCUIT COOLER

All Guaranteed Non-Flammable,
No Carbon Tet, Non-Toxic, Non-Drift
Tuner Cleaner And Guaranteed Not To
Affect Plastics.

The Only Brand Perfect For
Color TV and Black & White

FREE extender assembly for pin-point
application supplied with
ALL NO-NOISE PRODUCTS.

Electronic Chemical Corp.

813 Communipaw Ave. / Jersey City, N. J. 07304

Circle 111 on reader service card

For Top Performance And Value In Electronics —

Introducing The NEW Heathkit® IG-28

**Color Bar —
Dot Generator ...
Advanced IC Design
Gives 12 Patterns Plus
Clear Raster Display &
Eliminates Divider Chain
Instability Forever!**

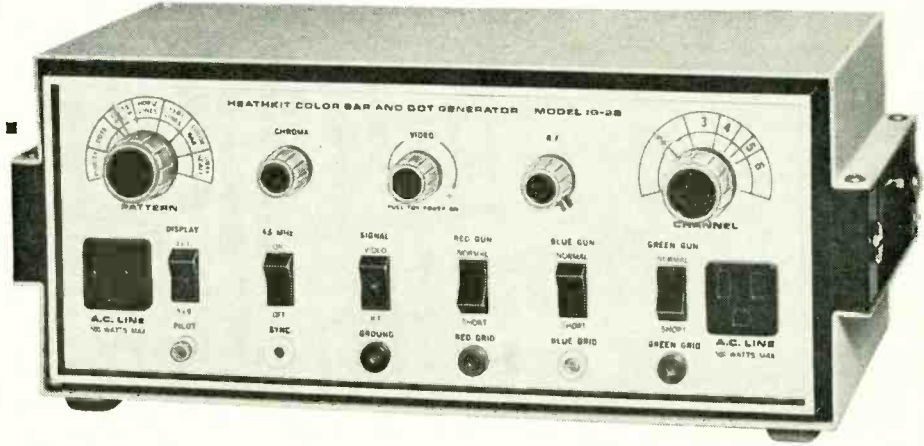

**Stable Integrated Circuitry
And Well-Engineered Layout**

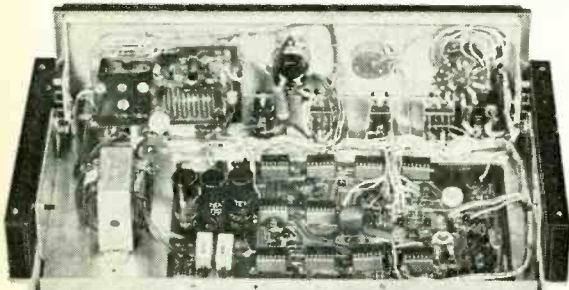

Circuit Board-Wiring Harness Construction. Note the extremely clean, open layout — another advantage of integrated circuitry. The Video board is upper left, the Divider board mounts on the chassis.

**The Most Advanced Instrument
In Color TV Service**

- All solid-state construction using Integrated Circuitry
- No divider chain adjustments
- Stable pattern display — no flicker, bounce or jitter
- Produces 12 patterns plus clear raster
- Instant switch selection of all functions
- Exclusive 3x3 display plus standard 9x9 display of all patterns
- Horizontal lines only one raster thick for added accuracy
- Variable front panel tuning for channels 2 through 6
- Variable front panel positive and negative video output
- Front panel negative going sync output
- Two handy AC outlets on front panel
- Built-in gun shorting circuit with lead piercing connectors
- Front panel switchable crystal controlled sound carrier
- Copper-banded transformer to reduce stray fields
- Safe three-wire line cord
- Fast, easy construction with two circuit boards and two wiring harnesses

The new Heathkit IG-28 is the ultimate signal source for all Color and B&W TV servicing. No other instrument at any price will give you as much stable, versatile TV servicing capability. Here are the details:

All Solid-State Circuitry produces dots, cross-hatch, vertical and horizontal lines, color bars and shading bars in the familiar 9x9 display . . . plus the exclusive Heath 3x3 display of all these patterns so necessary for static convergence, linearity and color demodulator phase adjustments . . . plus a clear raster that lets you adjust purity without upsetting AGC adjustments. Fifteen J-K Flip-Flops and associated gates count down from a crystal controlled oscillator, eliminating divider chain instability and adjustments.

Time-Saving Versatility. While many generators only give you one or two channel capability, the new IG-28 has variable front panel tuning for channels 2 through 6. The RF tank coil is actually etched into the circuit board for extra stability. Plus and minus going video signals are available at the turn of a front panel control. And for sync, in-circuit video or chroma problems, there's a front panel sync output. Convenient AC outlets are provided for degaussing coil, test instruments, TV set etc. Built-in gun shorting circuits and grid jacks are also included. Add any service type scope (with horizontal input) to the IG-28 and you have vectorscope display capability too. Other features include a crystal controlled sound carrier oscillator, a well regulated full wave power supply with dual primary copper-banded transformer, safe three-wire line cord, and rugged, compact Heath instrument styling. Two circuit boards and two wiring harnesses provide easy construction in about ten hours. Start enjoying the versatility you couldn't get before . . . put the remarkable new Heathkit IG-28 on your service bench now.

Kit IG-28, 8 lbs. \$79.95*

Fast Switch Selection Of Either

**Standard 9 x 9
Display**

OR

**Exclusive Heath
"3 x 3" Display**



Color Bars



Shading Bars



3x3 Color Bars



3x3 Shading

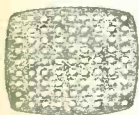

Dot Pattern



Cross Hatch



3x3 Dot



3x3 Cross Hatch



Horizontal Bars



Vertical Bars



3x3 Horizontal



3x3 Vertical

Look To The Leader

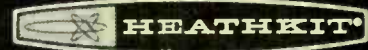

Now There are 4 Heathkit Color TV's ...
All With 2-Year Picture Tube Warranty

NEW Deluxe "681" Color TV With Automatic Fine Tuning

The new Heathkit GR-681 is the most advanced color TV on the market. A strong claim, but easy to prove. Compare the "681" against every other TV — there isn't one available for any price that has all these features. Automatic Fine Tuning on all 83 channels . . . just push a button and the factory assembled solid-state circuit takes over to automatically tune the best color picture in the industry. Push another front-panel button and the VHF channel selector rotates until you reach the desired station, automatically. Built-in cable-type remote control that allows you to turn the "681" on and off and change VHF channels without moving from your chair. Or add the optional GRA-681-6 Wireless Remote Control described below. A bridge-type low voltage power supply for superior regulation; high & low AC taps are provided to insure that the picture transmitted exactly fits the "681" screen. Automatic degaussing, 2-speed transistor UHF tuner, hi-fi sound output, two VHF antenna inputs . . . plus the built-in self-servicing aids that are standard on all Heathkit color TV's but can't be bought on any other set for any price . . . plus all the features of the famous "295" below. Compare the "681" against the others . . . and be convinced.

GRA-295-4, Mediterranean cabinet shown **\$119.50***
Other cabinets from \$62.95*

Deluxe "295" Color TV . . . Model GR-295

Big, Bold, Beautiful . . . and packed with features. Top quality American brand color tube with 295 sq. in. viewing area . . . new improved phosphors and low voltage supply with boosted B + for brighter, livelier color . . . automatic degaussing . . . exclusive Heath Magna-Shield . . . Automatic Color Control & Automatic Gain Control for color purity, and flutter-free pictures under all conditions . . . preassembled IF strip with 3 stages instead of the usual two . . . deluxe VHF tuner with "memory" fine tuning . . . three-way installation — wall, custom or any of the beautiful Heath factory assembled cabinets. Add to that the unique Heathkit self-servicing facilities like the built-in dot generator and full color photos in the comprehensive manual that let you set-up, converge and maintain the best color picture at all times, and can save you up to \$200 over the life of your set in service calls. For the best color picture around, order your "295" now.

GRA-295-1, Walnut cabinet shown **\$62.95***
Other cabinets from \$99.95*

Deluxe "227" Color TV . . . Model GR-227

Has same high performance features and built-in servicing facilities as the GR-295, except for 227 sq. inch viewing area. The vertical swing-out chassis makes for fast, easy servicing and installation. The dynamic convergence control board can be placed so that it is easily accessible anytime you wish to "touch-up" the picture.

GRA-227-1, Walnut cabinet shown **\$59.95***
Mediterranean style also available at \$99.50*

Deluxe "180" Color TV . . . Model GR-180

Same high performance features and exclusive self-servicing facilities as the GR-295 except for 180 sq. inch viewing area. Feature for feature the Heathkit "180" is your best buy in deluxe color TV viewing . . . tubes alone list for over \$245. For extra savings, extra beauty and convenience, add the table model cabinet and mobile cart.

GRS-180-5, table model cabinet and cart **\$39.95***
Other cabinets from \$24.95*

Now, Wireless Remote Control For Heathkit Color TV's

Control your Heathkit Color TV from your easy chair, turn it on and off, change VHF channels, volume, color and tint, all by sonic remote control. No cables cluttering the room . . . the handheld transmitter is all electronic, powered by a small 9 v. battery, housed in a small, smartly styled beige plastic case. The receiver contains an integrated circuit and a meter for adjustment ease. Installation is easy even in older Heathkit color TV's thanks to circuit board wiring harness construction. For greater TV enjoyment, order yours now.

kit GRA-681-6, 7 lbs., for Heathkit GR-681 Color TV's **\$59.95***

kit GRA-295-6, 9 lbs., for Heathkit GR-295 & GR-25 TV's **\$69.95***

kit GRA-227-6, 9 lbs., for Heathkit GR-227 & GR-180 TV's . . . **\$69.95***

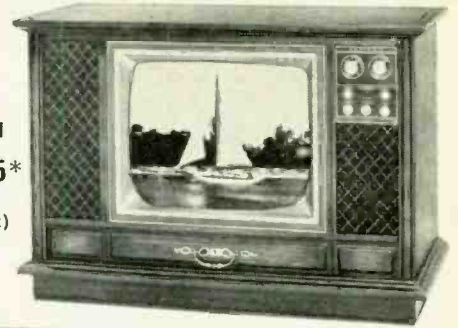

kit GR-681
\$499.95*
(less cabinet)



kit GR-295
now only
\$449.95*
(less cabinet)



kit GR-227
now only
\$399.95*
(less cabinet)



kit GR-180
now only
\$349.95*
(less cabinet)



New Wireless
TV Remote Control
For GR-295, GR-227
& GR-180

\$69.95*

New Wireless
TV Remote Control
For GR-681

\$59.95*

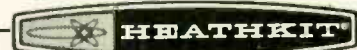

NEW
FREE 1969 CATALOG!
Now with more kits, more color. Fully describes these along with over 300 kits for stereo/hi-fi, color TV, electronic organs, electric guitar & amplifier, amateur radio, marine, educational, CB, home & hobby. Mail coupon or write Heath Company, Benton Harbor, Michigan 49022.

HEATH COMPANY, Dept. 20-4
Benton Harbor, Michigan 49022

Enclosed is \$ _____, plus shipping.

Please send model (s) _____
 Please send FREE Heathkit Catalog. Please send Credit Application.

Name _____

Address _____

City _____ State _____ Zip _____

Prices & specifications subject to change without notice. *Mail order prices; F.O.B. factory. CL-354

There's no substitute
for **SUCCESS...**



JAMES WONG—Research Engineer
Heald Engineering College Graduate

or IN-CLASS INSTRUCTION!

In electronics, it's the training that makes the difference. Employers require well-trained men and the first thing checked is where you gained your knowledge.

HEALD GRADUATES have many job offers with starting salaries often in excess of \$10,000 per year. AND advancement is rapid.

GET STARTED NOW. Be a

DRAFTSMAN—12 months
TECHNICIAN—15 months
ENGINEER (B.S. Deg.)—36 months
ARCHITECT (B.S. Deg.)—42 months

YOU are eligible for HEALD ENGINEERING COLLEGE if you have a high school education or the equivalent.

Increased income starts with success—success starts with your move to Heald. Send now for FREE brochures with more information on Heald in San Francisco and your future in Engineering.

FREE LIFETIME PLACEMENT SERVICE
VETERAN APPROVED



WRITE TODAY FOR DETAILS

HEALD Engineering College

1215 Van Ness Ave., San Francisco, California 94109

Please send me information about:

- ARCHITECTURE
ENGINEERING: Civil Electrical
Electronic Mechanical
TECHNOLOGY: Electronic Engineering
Technician (FCC)
Radio/Television Technician (FCC)
DRAFTING: Mechanical Electrical
Structural

I am interested in Day Evening courses
Also send an application.

NAME _____ AGE _____
ADDRESS _____
CITY _____
STATE _____
ZIP _____ PHONE _____

Circle 113 on reader service card

NEW TUBES AND SEMICONDUCTORS

NEW 5-WATT IC AMPLIFIER

General Electric's PA246 is a monolithic power amplifier delivering 5 watts (rms) of continuous power into a 16-ohm load. It is housed in an especially designed package with 8 leads and two heat-sink tabs as shown in the photo and drawings. Its applications include monaural and stereo phonographs and receivers, movie projectors, op amp boosters, relay drivers and servo amplifiers. The leads are staggered to simplify PC board design. The copper heat-sink tabs can be readily soldered to an external heat sink.

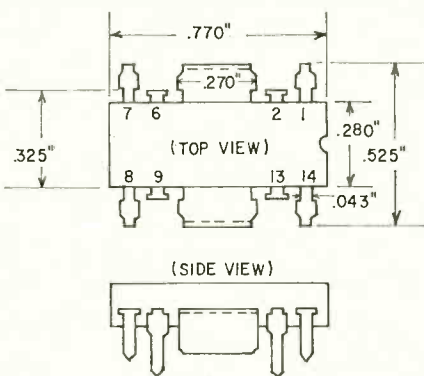

Fig. 1

The amplifier operates from a wide range of power supply voltages up to 37. Frequency response extends from 30 Hz to 100 kHz. Noise output is typically 70 dB below 5 watts. At 5 watts output, input sensitivity is 180

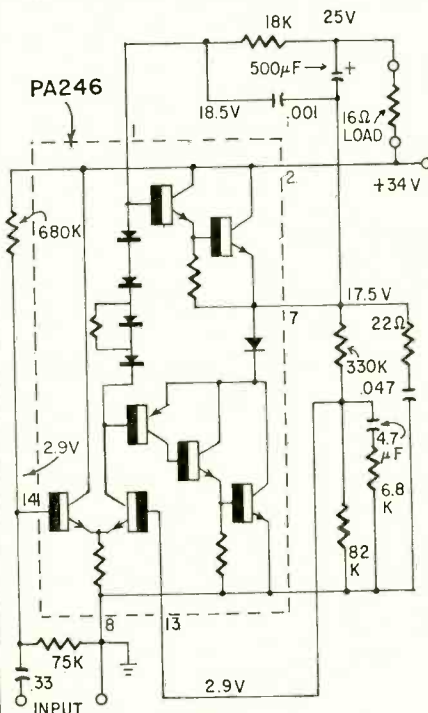

Fig. 2

90

RADIO-ELECTRONICS

SOLVE YOUR TV REPAIR PROBLEMS WITH TV TECH AID

A monthly TV publication of actual repairs, and troubles encountered in **OUR** business. The information will be gathered from technicians, field reps, and all the leading manufacturers.

TV TECH AID will be published in loose leaf sheets for simplified filing and easy reference. Each manufacturer will have its own page.

Each symptom will have a clearly marked schematic of the particular faulty stage. The faulty components, and corrections will be listed to aid in repair. No guess work.

It will contain current models, older models, circuit changes and modifications on various models as they occur.

The days of "Trial and Substitution" are over.

TIME LOST cannot be regained, and that is where the **PROFITS** are made.

ONE repair is worth more than four times the investment.

Each monthly issue will contain a series of timely sheets and the cost to you is only \$6.95 for a full years subscription.

TV TECH AID
P.O. BOX 603
KINGS PARK, L. I.
NEW YORK 11754

ENCLOSED IS A CHECK OR M.O. FOR \$6.95 PLEASE SEND 12 ISSUE OF TV TECH AID TO:

NAME _____
ADDRESS _____
CITY _____
STATE _____ ZIP _____

Circle 114 on reader service card

FREE!



NEW 1969
ALLIED
CATALOG
536
PAGES

SAVE ON:

- Electronic & Hobby Kits
- Stereo Hi-Fi
- Tape Recorders, Tape
- CB 2-Way Radios
- Walkie-Talkies
- FM-AM & AM Radios
- Shortwave Receivers
- Portable TV
- Phonographs
- Amateur Gear
- Intercoms & PA
- Automotive Electronics
- Test Instruments
- TV Antennas & Tubes
- Power Tools, Hardware
- Tubes, Transistors
- Parts, Batteries, Books

TOP SAVINGS ON THE BEST IN ELECTRONICS FOR EVERYONE

Shop by mail and save at Allied, world's largest electronics headquarters. Hundreds of money-saving values. NO MONEY DOWN. Up to 2 years to pay!

MAIL COUPON BELOW

ALLIED RADIO, Dept. 053 Please
P.O. Box 4398, Chicago, Ill. 60680 Print

NAME _____
First Middle Last
ADDRESS _____
CITY _____
STATE _____ ZIP _____

Circle 115 on reader service card

mW and total harmonic distortion is below 1% at 1 kHz. IM distortion (60 Hz and 6 kHz, mixed 4:1) averages around 2.4% between 0.05 and 5 watts output.

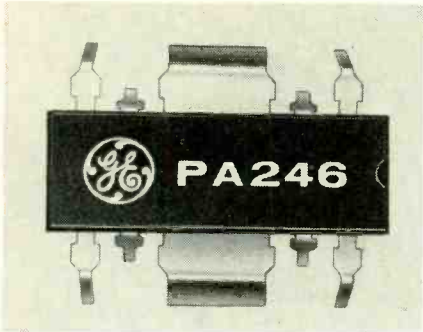

Dimensions of the PA246 are shown in Fig. 1. The IC and its test circuit are in Fig. 2.

This IC is available for \$3.84 in lots of 1 to 99. Additional information can be obtained from A&SP Distribution Services, General Electric Co., Building 705, Corporations Park, Scotia, N.Y. 12305.

IC FM STEREO DEMODULATOR

The Motorola MC1304 monolithic FM multiplex stereo demodulator not only separates the right and left audio channels of a stereo broadcast signal but also includes:

- A driver circuit for selectively turning on a panel-mounted indicator.
- An audio-muting circuit to eliminate interstation hiss by reducing the audio output by 55 dB during tuning.
- An automatic switching circuit for converting weak stereo signals (with poor signal-to-noise ratio) to monaural signals for distortion-free reception. External circuits can be added for adjustable switching threshold or to mute the receiver or monaural signals and permit only stereo stations to come in.

The MC1304 has a power dissipation of only 150 mW and can be used with 8-Vdc power supplies. Current drain is about 10 mA at 8.5 V and 40 mA at 10V—the latter is mostly for energizing the stereo lamp. A built-in hysteresis eliminates lamp flickering.

This IC is in the dual in-line ceramic or Motorola Unibloc case.

Stereo channel separation is typically 40 dB at 1.0 kHz, 30 dB at 100 Hz and 25 dB at 10 kHz. Rejection levels are 25 dB at 19 kHz, 20 dB at 38 kHz and 50 dB at 67 kHz. Total harmonic distortion is typically 0.5%. For more information, write to Technical Information Center, Motorola Semiconductor Products Inc., Box 20924, Phoenix, Ariz. 85036. **R-E**



DUAL CONVERSION
SMALL SIZE • LOW POWER DRAIN
• HIGH STABILITY • CRYSTAL CONTROLLED
 Specifically designed for simplicity of operation... efficiently engineered to give you years of service. Fits the smallest auto yet powerful enough to deliver a clear signal. Operates on 6 crystal controlled frequencies. Dual limiter & Foster Seely discriminator. Quadruple tuned RF stage for greater image rejection. Noise Free squelch, PLUG IN crystals for instant frequency change. Compatible with major continuous tone systems. Operates on 117VAC and 12VDC. Size: 6 7/8" x 2 5/8" x 8 1/2". Wt. 3 lbs. 8 oz.

FR-104
 (30-50 MHz) **\$140.00** Complete with AC and DC power cables, mounting bracket, less crystals.
FR-105
 (150-175 MHz) **\$140.00** Crystals \$5.00 ea.

SONAR RADIO CORPORATION
 73 Wortman Ave., Bklyn, N. Y. 11207 Dept. 985
 Please send me information on Model FR-104/105 FM Monitor Receivers.

Name _____
 Address _____
 City _____ Zone _____ State _____

Olson

FREE

Fill in coupon for a **FREE** One Year Subscription to **OLSON ELECTRONICS'** Fantastic Value Packed Catalog—Unheard of **LOW, LOW PRICES** on Brand Name Speakers, Changers, Tubes, Tools, Stereo Amps, Tuners, CB, Hi-Fi's, and thousands of other Electronic Values. Credit plan available.

NAME _____
 ADDRESS _____
 CITY _____ STATE _____
 GIVE ZIP CODE _____

If you have a friend interested in electronics send his name and address for a **FREE** subscription also.

OLSON ELECTRONICS

362 S. Forge Street Akron, Ohio 44308

NEW! SOLID STATE KITS

FOR ANY TAPE RECORDER

Automatic Recording-Level Control

Low-noise distortionless compressor — preamp easily installs in mike line. Easy-to-build kit with complete instructions.

MODEL ACP-1 KIT . . . \$18.50

Voice / Sound Actuated Controller

Voice operate any tape recorder, ham and CB transmitter. Ideal for intrusion alarms. Built-in relay switches up to 1 amp. Easy-to-build kit with complete instructions.

MODEL VOX-1 KIT . . . \$18.50

Other Kits

Audio Amplifiers ■ Power Supplies
Test Equipment ■ Treasure Locators
and many others

FREE Data sheets with circuit description, diagram and specifications for all kits.

CEI

CARINGELLA ELECTRONICS, Inc.
 P.O. Box 327 ■ Upland, California 91786
 Phone 714-985-1540

LISTEN TO: POLICE, FIRE and WEATHER REPORTS!

Perfect for Industrial, Commercial, Utility and Government Use

SONAR SENTRY VHF MONITOR RECEIVERS

Designed and engineered for simplicity of operation, compact enough to fit a shirt pocket yet powerful enough to deliver a clear clean signal—it's dependable • Operates on two crystal controlled VHF channels plus broadcast band • Completely solid state for long life use • Visible battery indicator to show battery condition at all times • Built in antenna • 5 7/8" H x 2 1/2" W x 1 3/8" D. Wt. 11 oz.

FR-103
 150-175 MHz
FR-106
 30-50 MHz

With Battery, Earphone, & less Crystals
 Crystals \$5.00 ea.

\$39.95

2 CHANNELS CRYSTAL CONTROLLED SOLID STATE POCKET SIZE WITH BROADCAST BAND A COMPLETE RECEIVER (not a converter)

SONAR RADIO CORPORATION
 73 Wortman Ave., Bklyn, N. Y. 11207 Dept. 985
 Please send me information on Model VHF Monitor Receivers.

Name _____
 Address _____
 City _____ Zone _____ State _____

Circle 116 on reader service card
 APRIL 1969

Circle 117 on reader service card

Circle 118 on reader service card

Clever Kleps

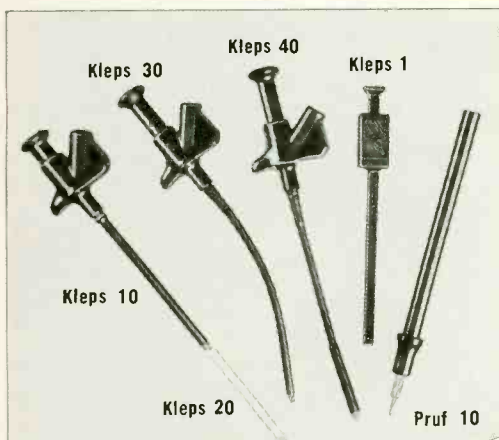

Test probes designed by your needs—
Push to seize, push to release (all Kleps spring loaded).

Kleps 10. Boathook type clamp grips wires, lugs, terminals. Accepts banana plug or bare wire lead. 4¾" long. **\$1.19**

Kleps 20. Same, but 7" long. **\$1.39**

Kleps 30. Completely flexible. Forked-tongue gripper. Accepts banana plug or bare lead. 6" long. **\$1.47**

Kleps 40. Completely flexible. 3-segment automatic collet firmly grips wire ends, PC-board terminals, connector pins. Accepts banana plug or plain wire. 6¼" long. **\$2.39**

Kleps 1. Economy Kleps for light line work (not lab quality). Meshing claws. 4½" long. **\$.99**

Prof 10. Versatile test prod. Solder connection. Molded phenolic. Doubles as scribing tool. "Bunch" pin fits banana jack. Phone tip. 5½" long. **\$.79**

All in red or black — specify.

For additional information, write for our complete catalog of — test probes, plugs, sockets, connectors, earphones, headsets, and miniature components.



Available through your local distributor, or write to:
RYE INDUSTRIES, INC.
123 Spencer Place, Mamaroneck, N.Y. 10543



Circle 119 on reader service card

WORLD'S FINEST
5-CORE SOLDER

ERSIN MULTICORE
NEW EASY DISPENSER PAK ONLY 69¢

BUY IT AT RADIO-TV PARTS STORES
MULTICORE SALES CORP. WESTBURY, N.Y. 11590
Circle 120 on reader service card

ENJOY THE "MUSIC ONLY" FM PROGRAMS
M. A. D.
MUSIC ASSOCIATED'S DETECTOR
NO COMMERCIALS—NO INTERRUPTIONS

It's easy! Just plug Music Associated's Sub Carrier Detector into multiplex jack of your FM tuner or easily wire into discriminator. Tune through your FM dial and hear programs of continuous commercial-free music you are now missing. The Detector, self-powered and with electronic mute for quieting between selections, permits reception of popular background music programs no longer sent by wire but transmitted as hidden programs on the FM broadcast band from coast to coast. Use with any FM tuner. Size: 5½" x 9". Shipping weight approx. 7 lbs.

KIT \$4950
(with pre-tuned coils, no alignment necessary)

WIRED \$7500 (Covers extra \$4.95 ea.)

Current list of FM Broadcast stations with SCA authorization \$1.00

MUSIC ASSOCIATED
65 Glenwood Road, Upper Montclair, N. J.
Phone: (201)-744-3337 07043

EQUIPMENT

*Sencore TF151
Transistor-FET Tester*



THINGS HAVE ALREADY GOTTEN TO the point where a transistor tester is indispensable. With PC construction we need instruments that will perform reliable in-circuit and out-of-circuit tests.

Field-effect transistors (FET's) are showing up in more equipment every day. Regular bipolar transistor testers won't check FET's.

Sencore's latest instrument in this category, the TF151 "In Or Out-of-Circuit Transistor-FET Tester," will do exactly four times as many things as its predecessor, the TR139.

The selector switch now has 12 positions, in four groups. Six positions are for bipolar transistor beta and leakage—both low- and high-power types. Each of these functions has a $\times 1$ and $\times 10$ scale, plus the vital I_{CBO} leakage test. There is also a special range for checking drift-field rf transistors (used in solid-state TV tuners as the rf amplifier).

FET's are tested on two separate ranges. The first, with $\times 1$ and $\times 10$ scales reading directly in micromhos, are used for common single-gate transistors. I_{GSS} or gate leakage can be read directly on the meter in micro-amperes.

Dual-gate FET's are checked on the second FET range. Gate leakage (I_{GSS}) is read by setting the selector to the lower leakage position. This is

COMING NEXT MONTH

Getting to Know the JFET. In May Tom Haskett gives you an introduction to the junction field-effect transistor. You'll learn how it works and how to use it.

REPORT

For manufacturer's literature, circle No. 122 on Reader Service Card.

exactly like checking a dual-triode on a tube tester.

Another important FET test is zero bias drain current. This is like I_{D0} in bipolars—the current which flows even though the FET should be biased to cutoff. Since FET's are often found in balanced circuits, both G_m and I_{DSS} must be matched. If one FET of a pair has blown, you'll have to check the replacements for a correct match.

Maximum power dissipation of a replacement FET as it is used in the circuit should also be checked. (Just use Ohm's law, the value of the supply voltage, and the value of the FET load resistor. The voltage drop across the load resistor will give you the value of the current. Then, the remaining voltage is dropped across the FET's drain-source resistance. Multiplying this out will give you the power dissipation of the FET.

Along with the instruction book, a very complete transistor reference book is included with the instrument. Beside the EIA types, it lists all imports, giving full data on each.

Most FET's in use are the depletion-mode type. Enhancement-mode FET's are rare, but since we may run into them in the future, a provision is made for testing them. Depletion-mode FET's use zero bias; enhancement-mode FET's use a positive bias. Bias can be selected by the BIAS-NORMAL-POSITIVE slide switch at the bottom of the panel. Correct bias settings are given in the reference book.

Like the TR139, the TF151 can be used to check completely unknown transistors without damaging them. You'll generally be able to tell by the circuit location whether a transistor is

a small-signal, rf, audio or power type. Even if the connections are reversed, the transistor won't be damaged.

In-circuit testing of both FET's and bipolars can save an enormous amount of time. Even if a transistor should check bad in the circuit, then check good after being removed, you've still found the trouble. There must be a bad part in that stage.

The TF151 is a very well-built instrument and meets the No. 1 prerequisite for all useful test instruments: "Will this thing make money for me by saving time?" In this case, I think the answer is: Yes. **R-E**

DEALERS! HOBBYISTS!



NEW AND FREE FROM WINEGARD

Our giant catalog of TV and FM antennas, mounts, wire, couplers, amplifiers, wall plates and antenna systems equipment!

Now, for the first time ever, you can have Winegard's sensational 52-page Catalog illustrating and describing the world's most complete line of high quality antennas and MATV equipment for homes and commercial buildings. That's right! Even if you're not in the electronics business, you can use this Catalog to select Winegard products. Send for your FREE copy today, plus the name of your nearest Winegard distributor.



WINEGARD COMPANY, 3013-2 Kirkwood Street
Burlington, Iowa 52601

Gentlemen: Please send me your FREE Catalog.

Electronics is my business. Electronics is my hobby.

NAME (please print) _____

ADDRESS _____

CITY _____

STATE _____

ZIP _____

U.S. GOV'T ELECTRONIC SURPLUS

Nationally Known-World Famous SURPLUS CENTER offers finest, most extensive, Government Surplus electronic units and components at a fraction of their original acquisition cost.

ORDER DIRECT FROM AD OR WRITE FOR CATALOGS

(IBM) SILICON DIODE RECTIFIERS

"Great Buys" in top quality, surplus, silicon diode rectifier units. (IBM Computer Units)

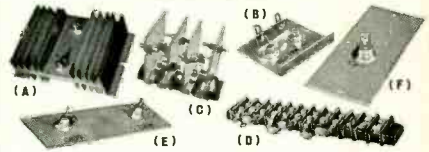

- (#REC-4) -- Two 12-amp., 50-V. silicon diodes on finest aluminum sinks. (1 lb.) (A) **\$2.69**
- (#22-925) -- Two 15-amp., 150-V. silicon diodes on finest aluminum sinks. (1 lb.) (B) **\$1.31**
- (#11-949) -- Eight 12-amp., 100-V. silicon diodes on heavy copper heat sinks. (1 lb.) (C) **\$3.97**
- (#11-900) -- Six 1-amp., 100-V. silicon diodes on Kulka strip. Very versatile. (1 lb.) (D) **\$1.71**
- (#22-926) -- Two 25-amp., 50-V. silicon diodes on heavy copper heat sink. (1 lb.) (E) **\$2.69**
- (#22-914) -- One 25-amp., 50-V. silicon diodes on heavy copper heat sink. (1 lb.) (F) **\$1.81**

COMPUTER TRANSISTORS ON HEAT SINKS

IBM Computer Quality Units

• (#22-928) -- Unit consists of one 150-watt power transistor on heavy, ribbed, aluminum heat sink. Many experimental uses. (1 lb.)
Cost Gov't Over \$10.00 **\$1.99**

• (#22-915) -- Unit consists of two 150-watt power transistors, 3 pots, several diodes, capacitors, resistors, etc. on heavy, ribbed aluminum heat sinks. Ideal for use as motor speed control. (4 lbs.)
Cost Gov't Over \$35.00 **\$4.91**

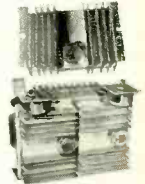

COMPUTER GRADE FILTER CAPACITORS

• Latest design, high MF units. Eliminate need for expensive chokes. 2-1/16" diam. x 4-1/2". (1-1/2 lbs.)
Orig. List over \$2.50

- (#C-14-1) -- 15,500-MF @ 10-Volts **.99**
- (#C-14-2) -- 1500-MF @ 150-Volts **.98**
- (#C-14-3) -- 5000-MF @ 55-Volts **.97**
- (#C-14-7) -- 12,500-MF @ 10-Volts **\$1.19**
- (#C-14-12) -- 750-MF @ 25-Volts **.98**



RUNNING TIME METER

• (#DX-104) -- Use to record number of operating hours of electric lights and electrical devices such as refrigerators, furnaces, etc. Records total hours, tenths and hundredths up in 9,999.99 hours. For 115-volt, 60-cycles. Size 4-1/2" x 2" x 2-1/2". Shipping weight 2 lbs.



\$5.69 Cost Over \$29.00

12 and 24-VOLT TRANSFORMER

• (#15-920) -- General Electric 115-volt, 60-cycle (o 12 and 24-volts @ 750-watts. Capacitv 42-amps. @ 24-volts, 64-amps. at 12-volts. Useful for battery chargers, running DC motors, etc. 7" x 9" x 5". (18 lbs.)
Cost Gov't Over \$35.00 **\$12.72**



EXPANDED SCALE 0 - 15 DCVM

• (#21-900) -- Brand new, expensive voltmeter reads 9.5 to 16-volts DC and 5 to 8-volts. Very useful for automotive and aircraft battery charge indicator, etc. D'Arsonval movement, black phenolic case. 7" x 5" x 2-1/2". (3 lbs.)
List \$32.50 **\$12.95**



SILICON DIODES

• (#REC-3) -- New, perfect, Westinghouse #770-A, 273-amp., 30-volt, 4N494. Fine for hi-current rectifier. (1 lb.)
List Over \$15.00 **\$5.90**



DIGITAL READ-OUT UNIT

Cost Gov't \$250.00 **\$3.97**

• (#EE-17) -- Sophisticated electronic unit contains 5-digit "read-out", electric motor, gear train, relays, etc. 5" x 6" x 7". (10 lbs.)



TYPICAL BUYS FROM OUR 1969 CATALOGS

• Our new 1969 Catalogs (Vol. #1 and #2) contain hundreds of tremendous buys in electronic equipment, power plants, welding generators, battery winches, hoists, electric golf carts, hydraulic gear, walkie-talkies, tape recorders, binoculars, surveying instruments, all types 115-volt power motors, blowers, relays, etc.

- \$100.00 Automatic Telephone Step Switches **\$9.95**
- \$275.00 Geared Battery Motors For Electric Cars **\$26.95**
- \$ 30.00 Standard Dial Handset Telephones **\$7.50**
- \$ 4.50 Power Transformer 115V to 25V **\$1.21**
- \$ 31.50 750-Watt Transformers 115V, to 24V **\$19.81**
- \$650.00 Power Plant 5000-Watts, 115-Volts **\$135.00**
- \$ 30.00 115-Volt AC Watt-hour Meters **\$5.95**
- \$ 42.50 115-Volt, 35-Amp. Clock Timer Switch **\$8.91**
- \$5-Vol. Discontinued Correspondence Course In Electrical Engineering **\$8.79**



SEND 25c COIN OR STAMPS FOR CATALOGS
All Items FOB Money Back Guarantee

SURPLUS CENTER

DEPT. RE 049 LINCOLN, NEBR. 68501





FREE Catalog Of The WORLD'S FINEST GOV'T SURPLUS ELECTRONIC BARGAINS

Now **BIGGER** and **BETTER** Than Ever!

MAIL THIS COUPON NOW!

NAME: _____
 ADDRESS: _____
 CITY: _____ STATE: _____ ZIP NO.: _____

FAIR RADIO SALES • Box 1105 • Lima, Ohio 45802

Circle 124 on reader service card

SCHOOL DIRECTORY

distinguished graduates

hold important engineering and business administration posts throughout U.S. Professionally-oriented college with outstanding placement record. Four-quarter year permits degree in three years. Fine faculty. Modern labs. Small classes. 300-acre campus. Accredited. Approved for vets. Moderate costs. Enter June, Sept., Jan., March. For Catalog, write Adm. Director.



TRI-STATE COLLEGE
 2449 College Avenue, Angola, Indiana 46703

TELEVISION RADIO COLOR TV

MAIL COUPON FOR FREE BOOK

Coyne Electronics Institute Dept. 49-C5
 1501 W. Congress Pkwy., Chicago, Ill. 60607

Send information as checked below

- HOME TRAINING in TV • Radio • Color TV • Electronics
 RESIDENT SCHOOL COURSES in Electronics, Electricity, Engineering, Radio-TV, Color TV, Refrigeration, and FCC

Name.....
 Address.....
 City.....State.....Zip.....
 Phone.....Age.....

VA Approved—GI Bill

GET INTO ELECTRONICS

V.T.I. training leads to success as technicians, field engineers, specialists in communications, guided missiles, computers, radar and automation. Basic & advanced courses in theory & laboratory. Electronic Engineering Technology & Electronic Technology curricula both available. Associate degree in 29 mos. B.S. also obtainable. G.I. approved. Graduates in all branches of electronics with major companies. Start Feb., Sept. Dorms, campus. High school graduate or equivalent. Catalog.

**VALPARAISO TECHNICAL
INSTITUTE**
 Dept. C, Valparaiso, Indiana 46388



Learn Electronics for your SPACE-AGE EDUCATION at the center of America's aerospace industry

No matter what your aerospace goal, you can get your training at Northrop Tech, in sunny Southern California.

COLLEGE OF ENGINEERING. Get your B.S. degree in engineering in just 36 months by attending classes year round. Most Northrop Tech graduates have a job waiting for them the day they're graduated!

A & P SCHOOL. Practical experience on real aircraft. One-year course prepares you for F. A. A. A & P certificate. **WRITE TODAY FOR CATALOG.**

NORTHROP INSTITUTE OF TECHNOLOGY
 1199 W. Arbor Vitae, Inglewood, Calif.

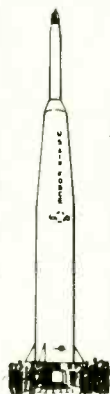

TRY THIS ONE

MAGNETIC GROUND LEAD

For a while, equipment ground leads were frequent casualties on my service bench. I'd either flip a heavy chassis over on them or yank the leads off while moving the set around.

I solved this problem by making up magnetic terminals for my scope and meter ground leads. I use a but-

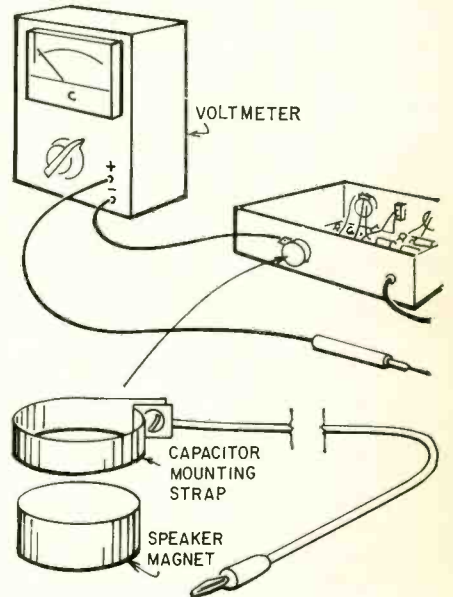

ton magnet or the core from a small PM speaker clamped in a capacitor mounting strap. The ground lead is soldered to the strap as shown above. The magnet can't be damaged by a toppling chassis and the lead can't be damaged while moving the test gear or equipment being serviced.—Peter Legon **R-E**

ELIMINATING HV-TRANSFORMER SQUEAL

Our TV receiver developed a squeal that was annoying, intermittent, and came from the high-voltage cage. By pushing with the handle of a toothbrush against the high-voltage winding, I could make the noise quit. The high-voltage winding was loose on the powder-iron core and set up a vibration at the horizontal scanning frequency. Several flat toothpicks pushed under the transformer winding beside the iron core made a quick repair. A coat of model airplane cement or glue was spread over the toothpick wedges, and the transformer has been quiet ever since.—Homer L. Davidson

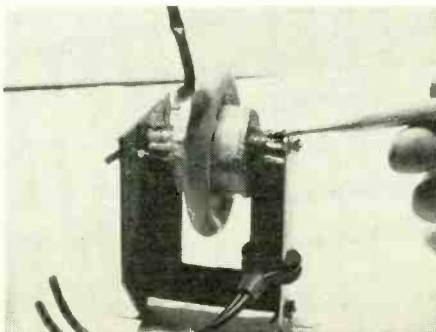

NOTEWORTHY CIRCUIT

WARBLE-TONE GENERATOR

Hardly any sound attracts attention as quickly as a strident warbling note. This is borne out by the warble-tone sirens that are replacing the more conventional type on fire, police and other emergency vehicles. A novel tone generator that should be a real attention-getter was described by A. B. Blackwell-Jones in *Wireless World* (London, England).

The circuit (see diagram) has transistors Q1, Q2 and Q3 each

coupled to the other two to form a free-running multivibrator. With the values shown, Q1 and Q2 oscillate around 700 Hz, Q1 and Q3 work at around 500 Hz while Q2 and Q3 loaf along at about 1.5 Hz. A square-wave pattern at Q1's collector alternates between the two higher rates at about 1.5 times per second.

When Q2 is turned off, multivibrator Q1-Q3 oscillates at 500 Hz, and when Q3 is off, Q1-Q2 oscillates at 700 Hz. The output is taken off a tap on Q1's collector load.

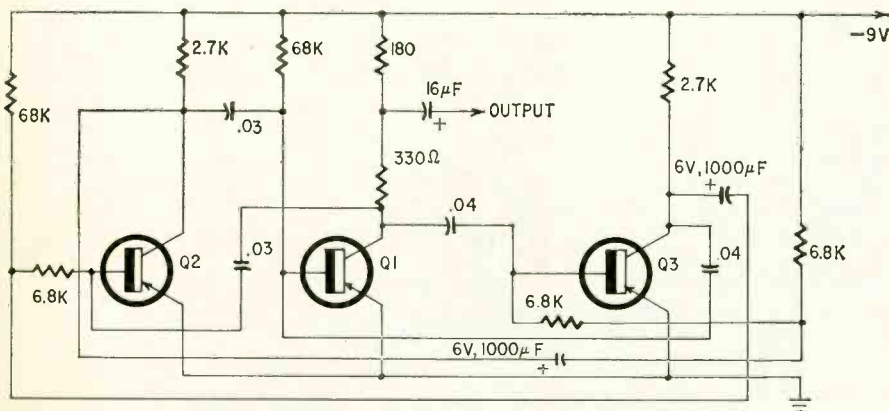

NOTE: Q1, Q2, Q3 ARE GENERAL-PURPOSE AUDIO TRANSISTORS WITH β 30-50

AUTO TURN AND BACKUP INDICATOR

When manually-operated turn and backup lights are added to most older vehicles, the lights are not visible from the cab, and are frequently left on when they should not be, resulting in highway confusion, tickets, or accidents.

This trouble can be reduced or eliminated by connecting a buzzer or lamp across each indicator lamp, so that the driver is aware of which lights are on. This works quite well, but three buzzers, or three "idiot lights" are likely to clutter up an already crowded dashboard, as well as imposing a maintenance problem.

By using three diodes, connected as shown in the diagram, a single buzzer or lamp can be used to indicate anything amiss. As applied, intermittent buzzing indicates that one of the flashing turn indicators is on; whereas a steady tone indicates that the backup light is on.

If a buzzer is used, be sure that it is loud enough to be heard over motor noise. The 0.02- μ F capacitor

across the buzzer reduces radio interference.

This circuit is designed for a negative ground system. If the system has a positive ground, reverse the diodes. Rated voltage of the buzzer should be that of the car battery. If it draws more than $\frac{1}{2}$ ampere, use larger diodes.—Ronald L. Ives R-E

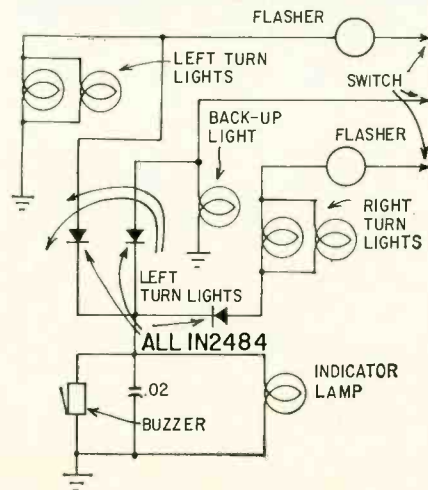

Delta Launches the COMPUTACH®*



The Great One!

*An exclusive computer-tachometer for precise RPM measurement in easy-to-build Kit form!



ONLY \$29.95 ppd.

Delta, pioneers in CD ignition who produced the fabulous MARK TEN®, now offer a precise computer-tachometer which obsolesces any type tachometer on the market today! You achieve unbelievable accuracy in RPM readings due to the advanced, solid-state electronic matched components used in the computer, coupled with the finest precision meter in the world. Works on all 2, 3, 4, and 6 cylinder 2 cycle and with 4-6-8 cylinder—4 cycle 12 volt engines.

- ▲ 0-8000 RPM range
- ▲ Perfect linearity—zero parallax
- ▲ Adjustable set pointer
- ▲ Wide angle needle sweep
- ▲ Translucent illuminated dial
- ▲ Chrome plated die-cast housing
- ▲ All-angle ball & socket mounting
- ▲ Use it with ANY ignition system
- ▲ Meter: 3 1/8" dia. X 3 3/8" deep
- ▲ Calibration kit included, no test eqpt. needed.

Orders shipped promptly. Satisfaction guaranteed.

DP 8-2

DELTA PRODUCTS, INC.

Send check today!

P.O. Box 1147 RE / Grand Junction, Colo. 81501

Enclosed is \$ _____ Ship ppd. Ship C.O.D.

Please send:

COMPUTACH® Kits @ \$29.95 ppd

Sold in Kit Form ONLY!

Name _____

Address _____

City/State _____ Zip _____

MARKET CENTER

AUDIO — HI-FI

WRITE for highest discounts on components, recorders, tapes, from franchised distributors. Send for FREE monthly specials. CARSTON, RFD #3, Route 7, Brookfield, Conn. 06804

RENT 4-track open reel tapes—all major labels—3,000 different—free brochure. STEREO-PARTI, 55 St. James Drive, Santa Rosa, Ca. 95401

HI-FI COMPONENTS, Tape Recorders, at guaranteed "WE will not be undersold" prices. 15-day moneyback guarantee. Two-year warranty. NO Catalog. Quotations Free. HI-FIDELITY CENTER, 239R East 149th St., N.Y., N.Y. 10451

Tapemates makes available to you ALL 4-TRACK STEREO TAPES. All labels—postpaid to your door—at tremendous savings. For free brochure write: TAPEMATES CLUB, 5280 RE West Pico Blvd., Los Angeles, Calif. 90019.

FOR SALE: Aviation radio sales, service business. SANDY'S AER, Griffin, Ga. 404-227-1442

FOR SALE! Brand new in original carton, 15 transistor AC-DC portable radio, AM/FM padded leather case with carrying handle and telescoping antenna, a bargain for only \$20.00. FORREST NANNEY, Box 84, Tupelo, Miss. 38801

SERVICING VIDEO AMPLIFIERS

The video circuitry is basically a broad-band amplifier (from detected video signals up to 4.2 Mhz), and it is usually easy to determine if the two stages are functioning. Signal tracing with a scope is the best procedure although the CRT can be used as an indicator. Noise can be injected into the base of the first video amplifier by touching it with your finger or a metal tool and noting the effect on the screen. If both stages are functioning, noise or flashing will appear on the screen.

"ARCTURUS" SALE

- 1700 transistor types at 39¢ each.
- 40 watt germanium power transistor, same as Delco 501. 2N278 (etc.). Cat. #349, 59¢ each.
- Color TV cartridge focus rectifier 6.5 kv. Used in every color TV. Cat. #CFR-20, 79¢ each.
- Motorola 2500 ma. at 1000 piv, high voltage/current epoxy silicon rectifier, axial leads. Cat. #HEP-170, 49¢ each.
- 2 Printed circuit I.F. transformers, 4 lug, 455 kc input and output, cat. #1909P4, 99¢ each.
- RCA UHF transistor type TV tuners. KRK-120 (long-shaft) cat. #UHF-20; KRK-120 (short-shaft) cat. #UHF-21, each \$4.98.
- RCA VHF transistor type TV tuners, KRK-146, cat. #VHF-74, \$9.99 each.
- Transistorized U.H.F. tuners used in 1965 to 1967 TV sets made by Admiral, RCA, Motorola, etc. Removable gearing may vary from one make to another. Need only 12 volts d.c. to function. No filament voltage needed. Easy replacement units. Cat. #UHF-567, \$4.95.
- U.H.F. Tuner-original units as used in TV sets such as RCA, Admiral, etc. covering channels 14 through 82, as part #94D173-2. Complete with tube. Drive gearing is removable. Can be used in most sets. Cat. #UHF-3, \$4.95.
- Color yokes. 70" for all round color CRT's. Cat. #XRC-70, \$12.95. 90" for all rectangular 19 to 25" color CRT's. Cat. #XRC-90, \$12.95.
- Kit of 30 tested germanium diodes. Cat. #100, 99¢.
- Silicon rectifier, octal based replacement for 5U4, 5Y3, 5AS4, 5AW4, 5T4, 5V4, 5Z4. With diagram. Cat. #Rect-1, 99¢ each.
- 7", 90° TV bench test picture tube with adapter. No ion trap needed. Cat. #7BP7, \$7.99.
- Tube cartons 6AU6 etc. size, \$2.15 per 100. 6SN7 etc. size, \$2.55 per 100. 5U4GB size, \$2.95 per 100. 5U4G size, 3¢ each.

Send for complete free catalog. Include 4% of dollar value of order for postage. \$5 MINIMUM ORDER. Canadian check, 8% dollar differential.

ARCTURUS ELECTRONICS CORP.

502-22nd St., Union City, N.J. 07087
Dept. MRE
Phone: 201-864-5568

MR. SCA OPERATOR

NEED A RELIABLE SOURCE FOR HIGH QUALITY, LOW COST SCA RECEIVERS, OR SCA DEMODULATOR UNITS?

A new and proven sub-carrier demodulation scheme using old established principles is now practical due to recent component developments and mass production. The resultant reduction in cost is passed on to you.

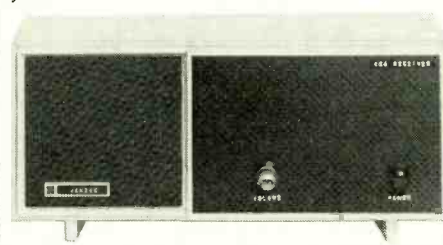

MODEL SCA-6137 SINGLE FREQUENCY FM RECEIVER. Size: 12" x 5 1/2" x 4 1/2". Price: \$69.95 (Quantity 1-9)

SCA-6137 FM Receiver Features:

- Range: 88 to 108 MHz • Frequency Field Adjustable • All Solid State Devices • RF Stage
- 3 IF Stages • Automatic Frequency Control
- Two 67 KHz Amplifier Stages • 67 KHz Ratio Detector • Adjustable Muting • Main/Sub-Carrier Switch • One Watt Audio Output • 4" Monitor Speaker • Provision for External Speaker • 117 Volt AC Operated.

Also available: SCA-3 sub-carrier demodulator PC Card with muting control. Size: 2 1/2" x 3" x 5/8". Operates on 6 to 12 Volts DC at 6 ma. Available from stock. Price: \$39.95 (Quantity 1-9)

Quantity discounts and detailed specifications are available to SCA operators.

Send orders and inquiries to:

JanZac Company; P.O. Box 177;
Stamford Conn. 06904
KenZac Company; P.O. Box 66251;
Houston, Texas 77006

ADVERTISING INDEX

RADIO-ELECTRONICS does not assume responsibility for any errors which may appear in the index below.

Accurate Instrument Company, Inc. 61
Allied Radio Corporation 90

Bell P/A Products Corporation 14
B & K (Division of Dynascan Corporation) ... 75
Brooks Radio and TV Corporation 82, 83
BSR USA Limited 68
Burstein-Applebee Company 70

Caringella Electronics, Inc. 91
Castle TV Tuner Service, Inc. 72
Cleveland Institute of Electronics 72, 62-65
CREI, Home Study Division of McGraw-Hill Book Co. 28-31

Delta Products, Inc. 15, 66, 95

Electronics and Control Engineers' Book Club Cover 111
Electronics Chemical Corporation 85
EMC Electronic Measurement Corporation 70
Enterprise Development Corporation 72
Essex International Inc., Controls Division, Siancor Inc. 68

Fair Radio Sales 94

Grantham School of Electronics 1

Heald Engineering College 90
Heath Company 86-89

International Crystal Mfg. Company 100
International Textbook Company 7

Judson Research and Mfg. Company 71

Kenwood 27

Lafayette Radio Electronics 73

Mallory Distributor Products Company 5
Microflame, Inc. 70
Multicore Sales Corporation 92
Music Associated 92

National Radio Institute 8-11
Nortronics 74

Olson Electronics, Inc. 91
Oxford Transducer Corporation 12

Pennwood Numechron Company 85
Pioneer Electronics Cover 11

RCA Electronic Components Test Equipment 13
Tubes Cover 1V
RCA Institutes 18-21
RCA Parts and Accessories 84
Rye Industries, Inc. 92

Sams and Company, Inc. Howard W. 22
Schober Organ 75
Sencore 16
Shure Bros. 69
Sidco Manufacturing Company 85
Sonar Radio Corporation 91
Sony Corporation of America 80, 81
Surplus Center 93
Sylvania (Subsidiary of General Telephone & Electronics) 67

TV Tech Aids 90

Winegard Company 93

Xcelite, Inc. 17

MARKET CENTER 96-99
Arcturus Electronics Corporation
Cornell Electronics Company
Edmund Scientific Company
Kenzac Company
Nytec Electronics
Poly Paks
Semi-Conductor Industries
Solid State Sales
Treasure Probe
United Radio Company

SCHOOL DIRECTORY 94
Coyne Electronics Institute
Northrop Institute of Electronics
Tri-State College
Valparaiso Technical Institute

ACOUSTIC RESEARCH, Dyna, Koss, Shure discount specialists. Free catalog and low Hi-Fi quotations available from **BOSTON AUDIO COMPANY**, 2 Common St., Waltham, Mass. 02154

TAPE RECORDER SALE. Brand new nationally advertised brands, \$10.00 above cost. Amazing discounts on stereo components. **ARKAY ELECTRONICS**, 1028-E Commonwealth Avenue, Boston, Mass. 02215

GENERAL

MAGNETS. All types. Specials-20 disc magnets, or 2 stick magnets, or 10 small bar magnets, or 8 assorted magnets. \$1.00. **MARYLAND MAGNET COMPANY**, 5412-G Gist, Baltimore, Maryland 21215.

TREASURE HUNTERS! PROSPECTORS! Relco's new instruments detect buried gold, silver, coins. Kits, assembled models. Transistorized. Weighs 3 pounds. \$19.95 up. Free catalog. **RELCO-A25**, Box 10839, Houston, Texas 77018

OPPORTUNITY AND ADVENTURE in Australia. Information \$2.00. Box 911 A, Union City, California 94587

JAPANESE NEW PRODUCTS MONTHLY! \$1.00. Refundable. **DEERE**, 10639 Riverside, North Hollywood, Calif.

ELECTRONICS

RECEIVING & INDUSTRIAL TUBES, TRANSISTORS. All Brands—Biggest Discounts. Technicians, Hobbyists, Experimenters—Request **FREE Giant Catalog** and **SAVE! ZALYTRON**, 469 Jericho Turnpike, Mineola, N.Y. 11501.

RADIO & TV TUBES 33¢ each. One year guaranteed. Plus many unusual electronic bargains. Free catalog. **CORNELL** 4217-E University, San Diego, California 92105

Discharge **IGNITION, PHOTOFLASH.** Free catalog parts, kits. **TRANSPARK**, Carlisle, Mass. 01741

ELECTRONIC IGNITION, C-D. \$28.95. Free brochure, S.C.I., P. O. Box 27, Boston, Mass. 02131

FIND BURIED TREASURE with most popular transistorized metal detector in the country. Treasure Probe available as kit (\$14.88), assembled (\$18.88), with powerful built-in speaker (\$24.88). Schematic, parts list, and step by step instructions, \$1.00. Ten day money back guarantee. Free catalog available. **TREASURE PROBE**, Dept. (RGA), P.O. Box 64, Lakewood, New Jersey 08710

SEMICONDUCTOR AND PARTS CATALOG over 100 pages free to Canadians. U.S. 50¢. **J & J ELECTRONICS**, Box 1437, Winnipeg, Manitoba, Canada

CONVERT any television to sensitive Big-Screen Oscilloscope. Only minor changes required. No electronic experience necessary. Illustrated plans \$2.00. **RELCO-A25**, Box 10563, Houston, Texas 77018

Details for a new free D.C. **POWER SOURCE**, using a special ground system. It will operate a 1 or 2 transistor radio at good speaker volume. Radio diagram and power source details. \$2.00. Satisfaction or money back. **THEODORE DIECKHAUS**, 109 W. 5th, Washington, Mo.

INTEGRATED CIRCUIT KITS: computer, audio, others. New catalog free. **KAY ENGINEERING**, Box 3932-D, Long Beach, California 90803.

HEAT SHRINKABLE SPAGHETTI. 1/2 off 6 inch lengths. 1/8" .16 pieces or 1/16" .28 pieces \$1.00 plus 14¢ postage. **D AND L ELECTRONICS**, Box 146, Powell, Ohio 43065

Ultra-sensitive and powerful **METAL DETECTORS** join the many who are finding buried coins, minerals, relics and artifacts. Don't buy till you see our free catalog of new models. Write **JETCO**—Box 132-RE, Huntsville, Texas 77340

INTEGRATED CIRCUITS / RECTIFIERS SEMICONDUCTORS / TRIACS

ER 900 TRIGGER DIODES These bidirectional trigger diodes are one of the best and cheapest methods of triggering SCR's and triacs. \$3/\$1.00

UNIUNCTIONS
Similar to 2N2419 Rbb of 5-7, stand off ratio of .6 and Ip of 12, with data sheet \$1.50

ZENERS
1 Watt 6.8-68V \$.40
10 Watt 7-200V \$.75

MOUNTING HDWE KITS
These kits are used to mount our SCR's, zeners, & rectifiers etc.
6 x 32 (3, 12 Amp rectifiers, 7 Amp SCR's) 6 sets/\$1.00
1/4 x 28 (20, 40 Amp rectifiers, 20 Amp SCR's) 4 sets/\$1.00

PRV	AMP	EPOXY AND CONTROLLED AVALANCHE RECTIFIERS 1 AMP
100	.07	
200	.09	
400	.12	
600	.18	
800	.22	
1000	.35	

N-CHANNEL PLASTIC TO-18 FET'S. Low noise, low leakage, gate current, gain to 9000µ mos. \$.80

IN2326 voltage & temperature compensating diodes 5/\$1.00

TRIACS

PRV	5A	10A
100	.90	1.20
200	1.40	1.75
300	1.75	2.25
400	2.25	2.75
500	2.60	3.25

CADMIUM SELENIUM PHOTO CONDUCTIVE CELLS. Dark resistance of 500 megohms. Sensitivity of 1-4.99 µa/ft candle with data sheet \$.80

HIGH-VOLTAGE NPN 150V VBCBO at 2.5A, hi gain in TO-66 pack \$.75

2N1163 a TO-3 PNP GERMANIUM TRANSISTOR rated at 35v and a gain of 50 at 25 amps. \$1.75

Silicon Power Rectifiers

PRV	3A	12A	40A
100	.09	.30	.75
200	.16	.50	1.25
400	.20	.70	1.50
600	.30	1.00	1.80
800	.40	1.25	
1000	.55	1.50	

9030 8 BIT MEMORIES.....\$5.95

LINEAR CIRCUITS
FM IF AMPLIFIERS \$.90
702C WIDE BAND DC AMPL. \$2.75
709C OPERATIONAL AMP. \$2.75
710C HI SPEED DIFF. COMPARATOR \$2.75
711C DUAL COMPARATOR \$2.75

DIGITAL RTL CIRCUITS
2-914 QUAD 2 INPUT GATE \$1.25
900 BUFFER \$1.25
925 DUAL 2 INPUT GATE EXPANDER \$1.25
923 JK FLIP FLOP \$1.25

NEON LIGHT of NIXIE TUBE DRIVERS. An NPN, TO-18, Si Transistor with a V_{CEO} of 120 3/\$1.00

Silicon Control Rectifiers TO-66 pack Studs

PRV	3A	7A	20A	70A
50	.35	.45	.70	
100	.50	.65	1.00	4.00
200	.70	.95	1.30	8.00
300	.90	1.25	1.70	
400	1.20	1.60	2.10	12.00
500	1.50	2.00	2.50	
600	1.80	2.40	3.00	16.00
700	2.20	2.80	5.00	

Send for our latest catalog featuring Transistors and Rectifiers; 325 Elm St., Cambridge, Mass.

OLID

Post Office Box 74D

TATE

Somerville, Mass. 02143

SALES

Tel. (617) 547-4005

Circle 137 on reader service card

UNUSUAL BARGAINS BY MAIL

SHOPPING MART

A selection of products available by mail for readers of Radio Electronics. All merchandise sold on money-back guarantee. Order by No. Send check or M.O.

GIANT FREE CATALOG! 148-PAGES



SEE MUSIC IN DAZZLING ACTION

MUSIC VISION DRAMATIC BREAKTHROUGH IN AUDIOVISUAL ENJOYMENT

See your favorite music translated into fantastically colorful patterns; each note creating its own unique, everchanging image in perfect time with the music. Easily attached to stereo, radio, tape recorder. Send 25¢ in coin for 16-page booklet. #9096EHL

DO-IT-YOURSELF KIT No. 71,009EH \$22.50 Ppd.
8" SET No. 71,030EH \$45.00 Ppd.
WALNUT CABINET MODEL No. 85,181EH \$99.50 FOB



NEW LOW-COST GEM TUMBLER

Become a rockhound! Fascinating hobby... loads of fun, inexpensive, easy. Make jewelry of all kinds—decorative bookends, table tops, etc. Simply tumble-finish readily available gemstones... then polish to high lustre... brings out beautiful colors. Rugged 3-lb. tumbler w/continuous duty motor compares to units selling for many times its price.

Stock No. 70,874EH \$10.75 Ppd.
6-LB. ROCK ASSORTMENT (10 TYPES)
Stock No. 70,868EH \$ 9.00 Ppd.



PROJECTION KALEIDOSCOPE

Infinite variety of brilliant color patterns which do not repeat. Specially designed, easily interchanged 9" diam. liquid wheel, 3" projection lens and Edmund Projector make it all possible. Easily operated. Large screen image at short projection distance perfect for backgrounds, light shows, parties, dances, etc. Front or rear proj.

Stock No. 71,121EH \$94.50 Ppd.
SOLID MULTI-COLORED GLASS ACCESSORY WHEEL (9" Diam.)
Stock No. 71,122EH \$15.00 Ppd.

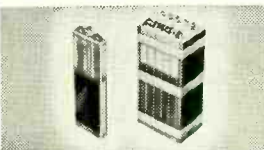

Ni-Cd BATTERY BARGAIN

Terrific value—slightly used gov't surplus. Lightweight 5 cell, 6 volt, 4 Amp-hour battery with almost unlimited life. Extremely high current output. Recharges in 1 hour with Edmund kit. Won't deteriorate when left discharged. Minimum maintenance—few drops of water per year. Rugged, shock-and-vibration resistant nylon case. Delivered partially charged, filled with electrolyte. 3 1/8" x 2" x 6" 2 lb.

BATTERY CHARGER KIT Stock No. 70,942EH \$15.00 Ppd.
CHARGER KIT Stock No. 70,807EH \$ 8.00 Ppd.



3" ASTRONOMICAL TELESCOPE

See moon shots, orbits—stars, phases of Venus, planets close up. 60 to 180 power—famous Mt. Palomar reflecting type. New, improved aluminized & overcoated 3" diameter f/10 primary mirror, ventilated cell. Equipped with 60X eyepiece and mounted 3X finder scope, hardwood tripod. FREE: "STAR CHART"; "HANDBOOK OF HEAVENS"; "HOW TO USE YOUR TELESCOPE" book.

Stock No. 85,050EH \$29.95 Ppd.
4 1/2" REFLECTOR TELESCOPE
Stock No. 85,105EH \$84.50 FOB
6" REFLECTOR TELESCOPE
Stock No. 85,086EH \$199.50 FOB

GIANT FREE CATALOG

Edmund, 300 Edscorp Building, Barrington, New Jersey 08007
148 PAGES — 1000'S OF BARGAINS

Completely new 1969 edition! Dozens of electrical and electromagnetic parts, accessories. Enormous selection of Astronomical Telescopes, Microscopes, Binoculars, Magnifiers, Magnets, Lenses, Prisms. Many war surplus. Items for hobbyists, experimenters, workshops, factory. Mail coupon for FREE catalog "EH".

NAME.....
ADDRESS.....
CITY.....
STATE..... ZIP.....

ORDER BY STOCK NUMBER • SEND CHECK OR MONEY ORDER • MONEY-BACK GUARANTEE

EDMUND SCIENTIFIC CO. 300 EDSCORP BUILDING BARRINGTON, NEW JERSEY 08007

Circle 138 on reader service card

SERVICEMEN • EXPERIMENTERS!

IF YOU WISH TO PURCHASE BRAND NEW TUBES

RECEIVING—SPECIAL PURPOSE BC TUBES AT OUTSTANDING MONEY SAVING VALUES.

WE CARRY THE LARGEST STOCK OF OBSOLETE AND THE LATEST TYPES OF EUROPEAN AND OTHER IMPORTED TUBES.

WE HAVE THE MOST UP TO DATE TUBES LISTED PLUS THE HARD TO GET TYPES. DON'T CONFUSE OUR TUBES WHICH ARE NEW WITH THE PULLOUTS AND REJECTS. SEND FOR OUR CATALOG.

UNITED RADIO COMPANY

ESTAB. 1920

56 FERRY ST., NEWARK, N.J. 07105

ELECTRONICS WRITERS, editors. Freelance work, various topics. Send resume. **TECHNICAL PUBLICATIONS**, P.O. Box 504, New Hyde Pk., N.Y. 11040

ELECTRONIC BARGAIN CATALOG on unusual kits, parts, do-it-yourself, stereo, intercoms. **ALCON**, P. O. Box 1348R, Lawrence, Mass. 01843

POWER SUPPLY KITS \$2.75-8.50. Nixie, decimal counter \$9.50. Surplus catalog. **MURPHY**, 204 Roslyn Ave., Carle Place, N.Y. 11514

JAPAN DIRECTORY. Electronics products and parts. General merchandise and Asia trade information. Just \$1.00 today. **IPPANO-KAISHA LTD.**, Box 6266, Spokane, Washington 99207

INVENTORS: protect your ideas! Free "recommended procedure". **WASHINGTON INVENTORS SERVICE**, 422X Washington Building, Washington, D.C. 20005

EDUCATION/ INSTRUCTION

FCC First Class License in six weeks—nation's highest success rate—approved for Veterans Training. Write **ELKINS INSTITUTE**, 2603E Inwood Road, Dallas, Texas 75235

ELECTRONICS ENGINEERING. Day or evening classes. Bachelor of Science Program evenings. Associate in Science Program day or night. If you are married or if you must work for a living while obtaining your education, this is the college for you. Approved for Veterans. **WESTERN STATES COLLEGE OF ENGINEERING**, 970 West Manchester Avenue, Inglewood, California 90301.

INVENTIONS & PATENTS

INVENTIONS WANTED. Patented; Unpatented. **GLOBAL MARKETING**, 2420-AE 77th Ave., Oakland, Calif. 94605

FREE "Directory of 500 Corporations Seeking New Products." For information regarding developments, sale, licensing of your patented/unpatented invention. Write: **RAYMOND LEE ORGANIZATION**, 230-U Park Avenue, New York City 10017.

NEW ALL SILICON ELECTRONIC IGNITION SAVES MONEY ON GAS & TUNE UP



Makes starting easier... delivers constant 32,000 volt output. Plugs last for 50,000 miles. Eliminates 2 out of 3 tune ups. Increases gas mileage. Free Details-SCI, Box 27, Boston, Mass.

ONE YEAR GUARANTEE! TUBES!

33¢ PER TUBE

100 OR MORE TUBES

30¢ ea.

Special! With Every \$10 Order

25¢ PER TUBE

Your Choice Of These Sizes
6AG5 6SN7
6W4 6CB6
6AU6 616 654

6D6	OZ4	6AU4	6X4
6DA4	1B3	6AU5	6X8
6DE6	1H5	6AU6	7B6
6DQ6	1J3/1K3	6AV6	7C5
6EA7	1L4	6AW8	7N7
6EM5	1T4	6AX4	7Y4
6F6	1U4	6BA6	10DE7
6FQ7	1X2	6BC5	12AE6
6GH8	3BZ6	6BG6	12A7
6H6	3DG4	6BJ6	12A7
6J5	5U4	6BL7	12AX7
6J6	5U8	6BN4	12BA6
6K6	5V4	6BN6	12BE6
6S4	5Y3	6BN8	12BH7
6SA7	6A6	6BQ6	12C5
6SH7	6A8	6BQ7	12SN7
6SJ7	6AB4	6BZ6	12W6
6SK7	6AC7	6C4	25L6
6SL7	6AF4	6C6	25Z6
6SN7	6AG5	6CB6	35W4
6SQ7	6AK5	6CD6	84/6Z4
6U7	6AL5	6CG7	56B7
6U8	6AN8	6CG8	6350
6V6	6AQ5	6CM7	6463
6W4	6AT6	6CZ5	7044
6W6	6AT8		

Tubes are New or Used and So Marked. Lab Tested. Ind. Boxed, Branded & Code Dated



DEPT. RE 4 4217 UNIVERSITY SAN DIEGO, CALIFORNIA 92105

Prestige & Success as an ELECTRONICS EXPERT!



HOME STUDY COURSES

TV SERVICING \$3.50

RADIO SERVICING \$3.00

BOTH COURSES \$6.00

2 STATION INTERCOM

12⁹⁵



A.C. 110 VOLT TRANSISTORIZED INTERCOM!

ONE YEAR GUARANTEE! DUMONT TUBES!



Brand New Except Glass!

TUBE TYPE	DUD DEP.	TUBE PRICE
19XP4	3.00	21.95
21AMP4	1.00	14.95
21CBP4	1.00	14.95
21CEP4	1.00	14.95
23FP4	3.00	18.95
21FJP22	5.00	24.95
23EGP22	20.00	79.95
25AP22	35.00	119.95
23AHP4	27.50	99.95
24AEP4	5.00	24.95
	1.00	22.95

Please remit full tube price plus dud deposit with order. Dud deposit will be returned immediately upon postpaid return of dud. No C.O.D.'s on picture tubes. All duds returned for refund must be under full vacuum.

FREE! CORNELL'S NEW CATALOG! WRITE FOR YOUR COPY TODAY!

RED & BLACK TUBE CARTONS

High Gloss, Clay Coated, Built in Diag. Partitions

SIZE	TUBE SIZE	10 CARTONS	100 CARTONS
MIN.	6AU6	.29	2.59
GT.	6SN7	.39	3.49
LG.GT	5U4GB	.59	5.29
G.	5U4G	.89	7.99

NO SUBSTITUTIONS WITHOUT YOUR PERMISSION! YOUR ORDER FREE IF NOT SHIPPED WITHIN 24 HRS.

Terms: Orders over \$5.00: Add 3c per tube shipping. Prepay in full and avoid C.O.D. charges. Send \$3.00 deposit on C.O.D. orders. Orders under \$5.00: Add 3c per tube plus 50¢ handling. Canadian and Foreign Orders: add approx. postage. No C.O.D. orders. Combine varied orders to bring order over \$5.00.

COMPUTER PROGRAMMING—the big opportunity career—new recognized correspondence course. No maths needed. Free brochure. CANADIAN INSTITUTE OF SCIENCE AND TECHNOLOGY, V63 Adelaide St. W., Toronto.

GOVERNMENT SURPLUS

JEEPS Typically From \$53.90 . . . Trucks From \$78.40 . . . Boats, Typewriters, Airplanes, Multimeters, Oscilloscopes, Transceivers, Electronics Equipment, Used, 100,000 Bid Bargains Direct From Government Nationwide. Complete Sales Directory and Surplus Catalog \$1.00 (Deductible First \$10.00 Order). SURPLUS SERVICE, Box 820-REL, Holland, Michigan 49423

WANTED

QUICK CASH . . . for Electronic EQUIPMENT, COMPONENTS, unused TUBES. Send list now! BARRY, 512 Broadway, New York, N. Y. 10012, 212 WALKER 5-7000.

CLASSIFIED COMMERCIAL RATE (for firms or individuals offering commercial products or services). 70¢ per word . . . minimum 10 words.

NON-COMMERCIAL RATE (for individuals who want to buy or sell personal items) 30¢ per word . . . no minimum.

Payment must accompany all ads except those placed by accredited advertising agencies. 10% discount on 12 consecutive insertions, if paid in advance. Misleading or objectionable ads not accepted. Copy for June issue must reach us before April 14.

WORD COUNT: Include name and address. Name of city (Des Moines), or state (New York) counts as one word each. Zone or Zip Code numbers not counted. (We reserve the right to omit Zip Code if space does not permit.) Count each abbreviation, initial, single figure or group of figures or letters as a word. Symbols or groups such as 8-10, COD, AC, etc., count as one word. Hyphenated words count as two words. Minor over-wordage will be edited to match advance payment.

Low gain—lack of gain

A set with a weak signal can be the most difficult to service. Very often all stages will seem to be operating properly. The problem is to find the one stage that actually is weak.

Using another rule of thumb, the gain for all stages in a given section should be about the same. Gain can be easily estimated by using signal injection and the CRT screen. First inject a signal at a suspect collector. Adjust the signal injector input until the interference or signal on the screen (or in the speaker) is just noticeable. Without touching any controls, move the signal injection probe to the base of the same stage. The signal output should improve appreciably. Each stage in the i.f. or each stage in the video section, should act the same as others.

R-E

**MAIL EARLY
IN THE DAY!**

ZIP CODE NUMBERS
BELONG
IN ALL ADDRESSES

YOUR POSTMASTER

PARTS

+ SERVICE +
FOR ALL
GERMAN

RADIOS-PHONOGRAPHS
TAPE RECORDERS

NYTEC ELECTRONICS CORP.

66-44 FOREST AVENUE
RIDGEWOOD, N.Y. 11227 492-2780

\$100,000 "EYE SEE" BONANZA BY POLY PAK INTEGRATED CIRCUITS!



PENNY SALE!

By far the biggest Integrated Circuit Sale in our history. NOBODY! That's right NOBODY under-sells Poly Paks. Imagine — buy 1 Integrated Circuit at our bargain price and get the 2nd one for ONLY 1¢ . . . that's right ONE CENT! NO LIMIT PER ITEM! Every item guaranteed as advertised. All include data on Integrated Circuits, schematics, and or hookups, and as much as 40 circuits. THIS OFFER IS LIMITED!

Fairchild No.	EACH	1c MORE
<input type="checkbox"/> 900	Buffer	1 for 1.49 2 for 1.50
<input type="checkbox"/> 902	R-S Flip Flop	1 for 1.49 2 for 1.50
<input type="checkbox"/> 903	3 In. Gate Nand/Nor	1 for 1.49 2 for 1.50
<input type="checkbox"/> 903-903*	3 Input gate Nand/Nor	1 for 1.49 2 for 1.50
<input type="checkbox"/> 904-904*	Half adder	1 for 1.49 2 for 1.50
<input type="checkbox"/> 910	Dual Two Input Gate	1 for 1.29 2 for 1.30
<input type="checkbox"/> 915	Dual 3 Input Gate Nand/Nor	1 for 1.49 2 for 1.50
<input type="checkbox"/> 923	JK-Flip Flop	1 for 1.49 2 for 1.50
<input type="checkbox"/> 923-923*	JK Flip Flop	1 for 1.69 2 for 1.70
<input type="checkbox"/> 925	Dual 2 Input Gate, Expander	1 for 1.49 2 for 1.50
<input type="checkbox"/> 927	Quad Inverter	1 for 1.49 2 for 1.50
<input type="checkbox"/> 930	Dual 4 Input Gate Nand/Nor	1 for 1.49 2 for 1.50
<input type="checkbox"/> 933	Dual Input Gate, Expander	1 for 1.49 2 for 1.50
<input type="checkbox"/> 944	Dual 4 Input Power Gate	1 for 1.49 2 for 1.50
<input type="checkbox"/> 945	Clocked Flip Flop	1 for 1.69 2 for 1.70
<input type="checkbox"/> 946	Quad 2 Input Gate Nand/Nor	1 for 1.49 2 for 1.50
<input type="checkbox"/> 948	Clocked Flip Flop	1 for 1.69 2 for 1.70
<input type="checkbox"/> 950	AC Binary	1 for 1.98 2 for 1.99
<input type="checkbox"/> 952	Dual 2 Pin Input Inverter Gate	1 for 1.29 2 for 1.30
<input type="checkbox"/> 954	Dual 4 Input and Gate	1 for 1.29 2 for 1.30
<input type="checkbox"/> 955	8 Input and Gate w 2 output	1 for 1.29 2 for 1.30
<input type="checkbox"/> 956	Dual 2 Input Buffer	1 for 1.29 2 for 1.30
<input type="checkbox"/> 957	Dual Rank (hold) Flip Flop	1 for 1.98 2 for 1.99
<input type="checkbox"/> 961	Dual 4 Input Gate w/expander	1 for 1.49 2 for 1.50
<input type="checkbox"/> 962	Triple Gate	1 for 1.49 2 for 1.50
<input type="checkbox"/> 963	Triple Gate	1 for 1.49 2 for 1.50

* Two identical IC's in one package

1 AMP. TOP HAT AND EPDIXES

PIV	Sale	PIV	Sale	PIV	Sale
50	5¢	800	19¢	1800	82¢
100	7¢	1000	29¢	2000	1.25
200	8¢	1200	42¢	3000	1.50
400	10¢	1400	55¢	4000	1.95
600	15¢	1600	69¢		

Actual Size

1 AMP MICROMINIATURE SILICON RECTIFIERS

PIV	Sale	PIV	Sale	
50	5¢	600	15¢	
100	7¢	800	19¢	
200	8¢	8¢	1000	29¢
400	10¢			

'GLASS AMP' SILICON RECTIFIERS

PIV	Sale	PIV	Sale	
50	5¢	600	15¢	
100	7¢	800	21¢	
200	8¢	9¢	1000	32¢
400	10¢	12¢	1200	45¢

PIV may be exceeded without the rectifier breaking down.

NE-2 NEON BULBS 20 for \$1

Terms: add postage. Rated: net 30, col's 25%
Phone Orders: Wakefield, Mass. (617) 245-3829
Retail: 211 Albion, St., Wakefield, Mass.

GIANT 1969 CATALOG ON: Parts, Rectifiers 10¢
 Transistors, SCRs, I.C.'s, Equipment, Etc.

POLY PAKS P.O. BOX 942R
LYNNFIELD, MASS. 01940

Buy 10 PAKS & CHOOSE 1 FREE

- 50 COILS AND CHOKES, if, rf, ant, osc, peaking, etc. \$1
- 65 HALF WATTERS, to 1 meg, 5% popular values to \$1
- 60 HI-QUALITY RESISTORS, 1/2, 1, 2W asst values ...\$1
- 10 RCA PHONO PLUGS & JACK SETS, tuners, etc. ...\$1
- \$25 SURPRISE PAK: transistors, rect, diodes, etc. ...\$1
- 2-PC INFRA-RED DETECTOR & FILTER SET science pro \$1
- 2 FIELD EFFECT TRANSISTORS, n channel, hobby ...\$1
- 50 TERMINAL STRIPS, 1 to 8 lug types ...\$1
- 3 PHOTO ELECTRIC CELLS, hi. imp., schematic ...\$1
- 3 TRANS'OR AMPLIFIER, WIRED, 3x2x3/4" schematic \$1
- 10 PRINTED CIRCUIT BOARDS, copper clad, 100 use \$1
- 10 TRANSISTOR SOCKETS, for pnp & npn types ...\$1
- 10 PANEL SWITCHES, toggle, slide, micro, rotary \$1
- 40 CORNING "LOW NOISE" resistors, popular 5% \$1
- 40 "MICRO" RESISTORS, 1/10W, 5% Hobby use \$1
- 50 GERMANIUM GLASS DIODES, 1N34, 1N48 no tes \$1
- 40 TOP HAT SILICON RECTIFIERS, no test asst value \$1
- 25 EPOXY RECTIFIERS, silicon asst, no test ...\$1
- 40 PRECISION RESISTORS, 1/2-2W, 1% asst values \$1
- 30 TRANSISTORS, rf, if, audio, osc, no test ...\$1
- 60 TUBULAR CONDENSERS, to .5mf to 1KV, asst ...\$1
- 50 DISC CONDENSERS, to .05mf npo, temp coef, asst \$1
- 60 TUBE SOCKETS, receptacles, plugs, audio, etc. ...\$1
- 30 POWER RESISTORS, to 25 watts, to 24K ohms ...\$1
- 6 "IBM" COMPUTER BOARDS, many trans, diodes \$1
- 3 2N3563 TRANSISTORS, npn, 600mc, 100hfe, epox \$1
- 10 VOLUME CONTROLS, to 1 meg, switch too! ...\$1
- 10 ELECTROLYTICS, to 100mf, tubulars too, asst ...\$1
- 50 RADIO & TV KNOBS, asst colors & styles ...\$1
- 10 TRANS'OR ELECTROLYTICS to 100mf, asst values \$1
- 40 "MICRO" CONDENSERS, for transistor circuitry \$1

For The Experimenter!

International EX Crystal & EX Kits

OSCILLATOR / RF MIXER / RF AMPLIFIER / POWER AMPLIFIER

Type EX Crystal

Available from 3,000 KHz to 60,000 KHz. Supplied only in HC 6/U holder. Calibration is $\pm .02\%$ when operated in International OX circuit or its equivalent. (Specify frequency)



\$395

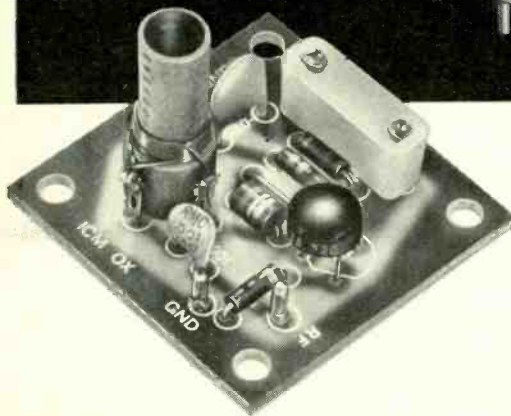

OX OSCILLATOR

Crystal controlled transistor type.

Lo Kit 3,000 to 19,999 KHz

Hi Kit 20,000 to 60,000 KHz

(Specify when ordering)

\$295

MXX-1 Transistor RF Mixer

\$3.50

A single tuned circuit intended for signal conversion in the 3 to 170 MHz range. Harmonics of the OX oscillator are used for injection in the 60 to 170 MHz range.

Lo Kit 3 to 20 MHz Hi Kit 20 to 170 MHz

(Specify when ordering)

SAX-1 Transistor RF Amplifier

\$3.50

A small signal amplifier to drive MXX-1 mixer. Single tuned input and link output.

Lo Kit 3 to 20 MHz

Hi Kit 20 to 170 MHz

(Specify when ordering)

PAX-1 Transistor RF Power Amplifier

\$3.75

A single tuned output amplifier designed to follow the OX oscillator. Outputs up to 200 mw can be obtained depending on the frequency and voltage. Amplifier can be amplitude modulated for low power communication. Frequency range 3,000 to 30,000 KHz.

BAX-1 Broadband Amplifier

\$3.75

General purpose unit which may be used as a tuned or untuned amplifier in RF and audio applications 20 Hz to 150 MHz. Provides 6 to 30 db gain. Ideal for SWL, Experimenter or Amateur.

Write for complete catalog.

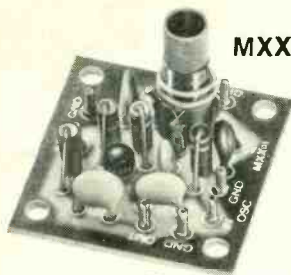

MXX-1



SAX-1



PAX-1

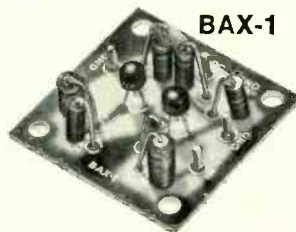

BAX-1



CRYSTAL MFG. CO., INC.

10 NO. LEE • OKLA. CITY, OKLA. 73102

Circle 148 on reader service card

Special introductory offer to new members of the ELECTRONICS AND CONTROL ENGINEERS' BOOK CLUB



For trial membership take

ANY ONE

for only \$ **1⁰⁰**

Values up to \$12.50

Choose bonus from Library Group A

For trial membership take

ANY ONE

for only \$ **2⁰⁰**

Values up to \$16.50

Choose bonus from Library Group B

For trial membership take

ANY ONE

for only \$ **3⁰⁰**

Values up to \$37.50

Choose bonus from Library Group C

#A850 MATHEMATICS FOR ELECTRONICS WITH APPLICATIONS by H. M. Nodelman and F. W. Smith. Pub. price, \$8.00. Club price, \$6.80

#A896 BASIC PULSE CIRCUITS by R. Blitzer. Pub. price, \$8.50. Club price, \$7.25

#A530 PROJECT ENGINEERING by V. Hajek. Pub. price, \$9.75. Club price, \$8.30

#A355 FIELD-EFFECT TRANSISTORS by L. J. Sevin. Pub. price, \$10.00. Club price, \$8.50

#A475 MOSFET IN CIRCUIT DESIGN by R. H. Crawford. Pub. price, \$10.00. Club price, \$8.50

#A142 TUNNEL-DIODE AND SEMI-CONDUCTOR CIRCUITS by J. M. Carroll. Pub. price, \$11.00. Club price, \$9.35

#A509 MATHEMATICS MANUAL by F. S. Merritt. Pub. price, \$11.95. Club price, \$10.15

#A955 ELECTRONIC TESTING by L. L. Farkas. Pub. price, \$12.00. Club price, \$10.25

#A144 DESIGN MANUAL FOR TRANSISTOR CIRCUITS by J. M. Carroll. Pub. price, \$12.50. Club price, \$10.65

#B978 TRANSFORMERS FOR ELECTRONIC CIRCUITS by N. R. Grossner. Pub. price, \$14.00. Club price, \$11.90

#B905 INTRODUCTION TO RADAR SYSTEMS by M. I. Skolnik. Pub. price, \$14.50. Club price \$12.35

#B677 DATA TRANSMISSION by W. R. Bennett. Pub. price, \$14.50. Club price \$12.35

#B270 MICROWAVE MEASUREMENTS by E. L. Ginzton. Pub. price, \$15.50. Club price \$13.25

#B310 AUTOMATIC FEEDBACK CONTROL SYSTEMS by J. G. Truxal. Pub. price, \$15.50. Club price, \$13.25

#B690 MODERN OPTICAL ENGINEERING by W. J. Smith. Pub. price, \$16.00. Club price, \$13.60

#737 TRANSISTOR CIRCUIT DESIGN by Texas Instruments, Inc. Staff. Pub. price, \$16.50. Club price, \$14.05

#B981 DIGITAL COMPUTER AND CONTROL ENGINEERING by R. S. Ledley. Pub. price, \$16.50. Club price, \$14.05

#C509 ELECTRONIC AND RADIO ENGINEERING by F. E. Terman. Publisher's price, \$17.50. Club price, \$14.95

#C861 FLUID AMPLIFIERS by J. M. Kirshner. Pub. price, \$17.75. Club price \$15.10

#C381 PULSE, DIGITAL, AND SWITCHING WAVEFORMS by J. Millman and H. Taub. Pub. price, \$18.00. Club price, \$15.30

#C360 ELECTRONIC ANALOG AND HYBRID COMPUTERS by G. A. Korn and T. M. Korn. Pub. price, \$18.75. Club price, \$15.95

#C085 DIGITAL AND SAMPLED-DATA CONTROL SYSTEMS by J. T. Tou. Pub. price, \$19.75. Club price, \$16.75

#C304 HANDBOOK OF SEMICONDUCTOR ELECTRONICS 2/e by L. P. Hunter. Pub. price, \$22.50. Club price, \$19.10

#C290 ANTENNA ENGINEERING HANDBOOK by H. Jasik. Pub. price, \$27.75. Club price, \$23.60

#C371 SYSTEM ENGINEERING HANDBOOK edited by R. E. Machol. Pub. price, \$29.50. Club price, \$25.00

#C503 AMPLIFIER HANDBOOK by R. F. Shea. Pub. price, \$37.50. Club price, \$29.50

You can save time and money by using this coupon to join today

YOUR BONUS BOOK comes with your first selection

YOUR FIRST CLUB SELECTION available from any Library Group above

HERE is a professional book club designed to meet day-to-day engineering needs by providing practical books in your field on a regular basis at below publisher prices.

How the club operates: Basic to the Club's service is its publication, the *Electronics and Control Engineers' Book Club Bulletin*, which brings you news of books in your field. Sent to members without cost, it presents in detail the featured book of the month as well as many alternate selections also available at special members' prices.

When you want to examine the Club's featured book, you do nothing. It will be mailed as a regular part of your Club service. If you prefer one of the alternate selections—or if you want no book at all for that month—you let us know by returning the convenient card enclosed with each Bulletin.

As a member, you agree only to take four books in two years. Considering the many essential books published in your field, there will surely be at least four that you would want to own anyway. By joining the Club, you save both money and the trouble of searching for the best books.

NEVER A MEMBERSHIP FEE

ELECTRONICS AND CONTROL ENGINEERS' BOOK CLUB
582 Princeton Road, Hightstown, N.J. 08520

Please enroll me as a member of the Electronics and Control Engineers' Book Club and send me the two books indicated below. I am to receive the bonus book at the special Library Group price and my first selection at the special Club price. These books are to be shipped on approval, and I may return them both without cost or further obligation. If I decide to keep the books, I agree to purchase as few as four additional books during the next two years at special Club prices guaranteed to be about 15% under publisher prices.

Write Code No. of
bonus book
here

Write Code No. of
first selection
here

Name _____

Address _____

City _____

State _____ Zip _____

(Offer good in U.S. and Canada only.)

The brand new RCA Color-TV Service Handbook (1A1759) gives you all the specific service information you need to do routine service adjustments and preliminary trouble-shooting on 15 Makes of 1967 and 1968 Color Sets...including Admiral, Airline, RCA, Silvertone, Curtis Mathes, Emerson, General Electric, Magnavox, Motorola, Olympic, Packard Bell, Philco, Zenith, Hoffman, Sylvania. In fact, all the data you usually need on a service call is in this book!

And it's free when you order the RCA Color Pack '69. You get an assortment of 21 RCA receiving tubes, representing ten popular types for color TV plus the new RCA Color-TV Service Handbook, all for the price of the tubes alone! Order the Color Pack '69 from your local participating RCA Distributor today! RCA Electronic Components, Harrison, N.J. 07029.

This is free

when you order this



RCA